

TM 10-4520-264-12&P

TECHNICAL MANUAL

OPERATOR'S AND UNIT MAINTENANCE MANUAL
INCLUDING REPAIR PARTS AND SPECIAL TOOLS LISTS (RPSTL)

FOR

SPACE HEATER, CONVECTIVE 60K BTU (SHC-60K)

NSN: 4520-01-520-6477

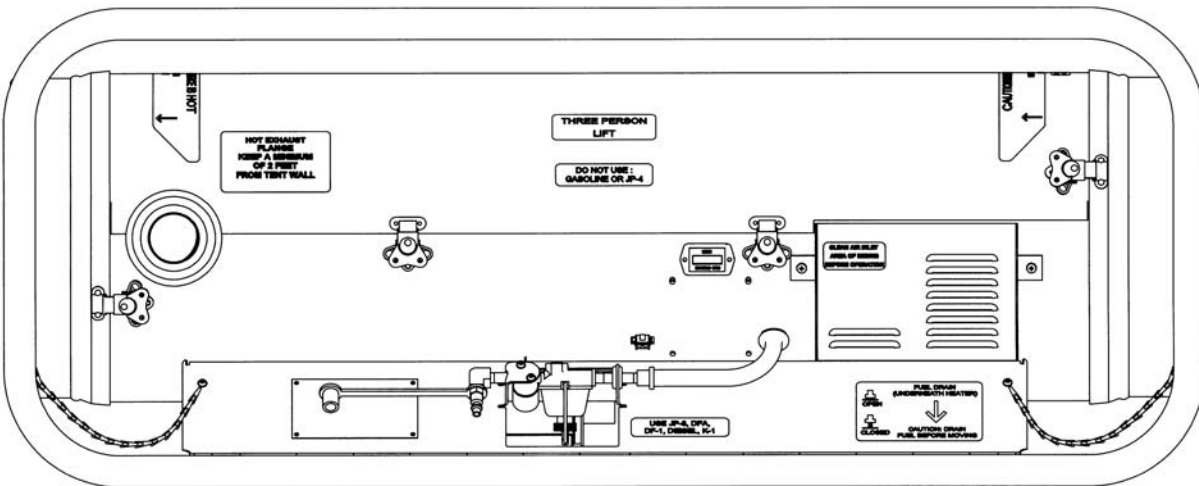

DISTRIBUTION STATEMENT A – Approved for public release; distribution is unlimited.

HEADQUARTERS, DEPARTMENT OF THE ARMY

5 MARCH 2007

WARNING SUMMARY

This warning summary contains general safety warnings and hazardous materials warnings that must be understood and applied during operation of this equipment. Failure to observe these precautions could result in serious injury or death to personnel. Also included are explanations of safety and hazardous materials icons used within this technical manual.

EXPLANATION OF SAFETY WARNING ICONS



CARBON MONOXIDE – human figure showing gaseous substance being inhaled into respiratory system, demonstrating potential hazard.



CHEMICAL - drops of liquid on hand shows that the material will cause burns or irritation to human skin or tissue.



CRYOGENIC - hand in block of ice shows that the material is extremely cold and can injure human skin or tissue.



ELECTRICAL - electrical wire to arm with electricity symbol running through human body shows that shock hazard is present.



EXPLOSION - rapidly expanding symbol shows that the material may explode if subjected to high temperatures, sources of ignition, or high pressure.



FIRE - flame shows that a material may ignite and cause burns.



FLYING PARTICLES - arrows bouncing off face with face shield shows that particles flying through the air will harm face.



HEAVY OBJECT – human figure stooping over heavy object shows physical injury potential from improper lifting technique.



HOT AREA - hand over object radiating heat shows that part is hot and can burn.



POISON - skull and crossbones shows that a material is poisonous or is a danger to life.



SHARP OBJECT - pointed object in hand shows that a sharp object presents a danger to limb.

GENERAL SAFETY WARNINGS DESCRIPTION



WARNING

Carbon monoxide is a gas without color, smell, or taste, but can kill you. Breathing carbon monoxide may produce symptoms of headache, dizziness, loss of muscular control, a sleepy feeling, and unconsciousness or coma. Brain damage or death can result from heavy exposure. Carbon monoxide is present in the exhaust fumes of any fuel-burning heaters and internal combustion engines. Fatal concentrations of carbon monoxide will occur if the Space Heater, Convective 60K BTU (SHC-60K), or any fuel burning space heater, is operated in an enclosed area such as a tent or structure.

Precautions must be followed to ensure operator's safety when the Space Heater, Convective 60K BTU (SHC-60K) is in operation.

- DO NOT operate the SHC-60K in an enclosed area.
- Direct the SHC-60K exhaust outlet away from shelters or personnel.
- BE ALERT at all times during operating procedures for carbon monoxide poisoning. If symptoms are present, IMMEDIATELY evacuate personnel and seek medical attention.
- BE AWARE the field protection mask used for nuclear-biological-chemical attack WILL NOT protect you from carbon monoxide poisoning.

THE BEST DEFENSE AGAINST CARBON MONOXIDE POISONING IS GOOD VENTILATION.



WARNING

Do not touch cold metal parts with bare hands – always wear gloves. Exposed skin may adhere to cold metal parts, or produce frostbite can cause permanent injury to personnel, requiring medical attention to afflicted areas.



WARNING

Personnel injury/cuts. Leather glove hand protection must be worn. The use of protective gloves will significantly reduce the risk of cut injury. Failure to do so could result in serious injury to fingers or hands.



WARNING

Fuels are toxic and flammable. Do not refuel near open flame or other ignition sources. Only refuel in a well-ventilated area. Wear eye/face protection, avoiding contact with skin and clothes, and don't breathe vapors. If contact with eyes or skin is made, immediately flush with clean water and get medical aid for eyes. If contact with clothing or skin is made, immediately remove contaminated clothing and clean skin with mild soap or cleanser and flush with clean water.

Always store fuel cans in a well-ventilated area as far away from open flames and other potential ignition sources as possible. Leaking or spilled fuels will create a fire danger-injuries/death and environmental damage. Fuel spills must be cleaned up in accordance with local requirements.

Failure to observe fuel requirements could cause damage to the heater assembly, fire danger-potential explosion, and injury or death to personnel within or around the tent and the heater assembly.



WARNING

Excessive weight hazard. The Space Heater, Convective 60K BTU (SHC-60K) weighs approximately 118 pounds (53.5 kg) with accessories and transit bag. Four persons must carry the unit, lifting with legs, not back, to prevent injury. Failure to do so may result in serious back or other muscular skeletal injuries.



WARNING

The heater has been designed to operate in dusty or sandy conditions. However, some forms of very fine dusts may be explosive (e.g., flour, chaff, coal, etc.). Before operation of the heater in dusty conditions, the type of dust shall be identified to insure that it is not explosive in nature.



WARNING

DO NOT MOVE THE HEATER ASSEMBLY WHILE ANY OF THE ADVISORY LIGHTS ARE LIT.

Small, portable, shelter heaters of this type are not designed to be moved during operation or before purge cycles are complete. Serious injury, burns, or death can occur if the heater assembly is moved while operating or before the HEATER ON/ON-HOLD advisory light goes OFF indicating the end of operation, post purge, and cool down cycle completion.

During operation, some metal components of the heater assembly, such as the louver on the outlet duct, the upper and lower heater housing assemblies, combustion exhaust pipe, etc., can cause severe burn injuries if contact with bare skin occurs.

During heater operation, air leaving the HEATED AIR OUTLET of the heater and passing through outlet duct with louver may exceed 220°F. Make sure tent personnel are aware of burn hazards and equipment hazards presented by the heated air and the louver.

Combustible material must be kept at least 2 feet away from the sides of the heater during operation.

Do not attempt service procedures on a burner that has recently been in operation. Do not attempt service procedures on a burner that has recently been in operation. Switch heater ON/OFF control to the OFF position, wait until the green HEATER ON/ON-HOLD light is OFF, and let the burner cool down before performing these procedures to avoid the possibility of serious burns.



WARNING

Gasoline, JP-4, used motor oil, solvents, fuel mixtures, or other unauthorized fuels must NOT be used with the Space Heater, Convective 60K BTU (SHC-60K) under any circumstance. Only JP-8 or an approved alternate fuel as detailed in WP 0002 00, Table 2, may be used. Failure to observe fuel requirements creates a potential for a fire or explosion hazard, with resulting damage to the heater assembly and injury or death to personnel within or around the tent and the heater assembly.

Always place fuel can and stand in well-ventilated area as far away from open flames and other potential ignition sources as possible. Leaking or spilled fuels will create environmental damage - fuel spills must be cleaned up in accordance with local requirements.

Always switch heater ON/OFF control to the OFF position and wait until the green HEATER ON/ON-HOLD light is OFF before refueling.



WARNING

Fuels are toxic and flammable. Do not refuel near open flame or other ignition sources. Only refuel in a well-ventilated area. Wear eye/face protection, avoiding contact with skin and clothes, and don't breathe vapors. If contact with eyes or skin is made, immediately flush with clean water and get medical aid for eyes. If contact with clothing or skin is made, immediately remove contaminated clothing and clean skin with mild soap or cleanser and flush with clean water.

CHANGE
NO. 1

HEADQUARTERS,
DEPARTMENT OF THE ARMY
WASHINGTON, D.C., 15 AUGUST 2007

TECHNICAL MANUAL
OPERATOR'S AND UNIT MAINTENANCE MANUAL
INCLUDING REPAIR PARTS AND SPECIAL TOOLS LISTS (RPSTL)
SPACE HEATER, CONVECTIVE 60K BTU (SHC-60K)

DISTRIBUTION STATEMENT A. Approved for public release; distribution is unlimited.

TM 10-4520-264-12&P, 5 March 2007, is updated as follows:

1. File this sheet in the front of the manual for reference.
2. This change was implemented to include national stock numbers in the Repair Parts and Special Tools List. This change also implements the Army Maintenance Transformation and changes the Maintenance Allocation Chart (MAC) to Support Field and Sustainment Maintenance.
3. New or updated text is indicated by a vertical bar in the outer margin of the page.
4. Remove old pages and insert new pages as indicated below:

Remove Pages

A/(B Blank)
i-ii
DA 2028 Instructions
Sample DA 2028
DA 2028

Insert Pages

A/(B Blank)
i-ii
DA 2028 Instructions
Sample DA 2028
DA 2028

5. Replace the following work packages with their revised version:

Work Package Number

WP 0001 00
WP 0066 00
WP 0067 00
WP 0070 00
WP 0071 00
WP 0080 00
WP 0082 00
WP 0085 00
WP 0088 00

By Order of the Secretary of the Army:
C1

GEORGE W. CASEY, JR.
General, United States Army
Chief of Staff

Official:

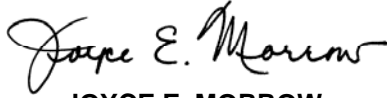

JOYCE E. MORROW
Administrative Assistant to the
Secretary of the Army
0721104

DISTRIBUTION: To be distributed in accordance with the initial distribution number (IDN) 256928 requirements for TM 10-4520-264-12&P.

INSERT LATEST CHANGED PAGES/WORK PACKAGES. DESTROY SUPERSEDED DATA.

LIST OF EFFECTIVE PAGES/WORK PACKAGES

NOTE: The portion of text affected by the change is indicated by a vertical bar in the outer margins of the page. Changes to illustrations are indicated by a vertical bar adjacent to the title. Zero in the "Change No." column indicates an original page or work package.

Date of issue for the original manual and changed pages/work packages are::

Original 5 March 2007
Change 1 15 August 2007

TOTAL NUMBER OF PAGES FOR FRONT AND REAR MATTER IS 42 AND TOTAL NUMBER OF WORK PACKAGES IS 94, CONSISTING OF THE FOLLOWING:

Page/WP No.	Change No.	Page/WP No.	Change No.	Page/WP No.	Change No.
Title	0	WP 0031 00 (2 pgs)	0	WP 0065 00 (2 pgs)	0
a-f	0	WP 0031 01 (4 pgs)	0	WP 0066 00 (4 pgs)	1
i – ii	1	Chp 4 title page	0	WP 0067 00 (4 pgs)	1
iii-vi	0	WP 0032 00 (2 pgs)	0	WP 0068 00 (8 pgs)	0
Chp 1 title page	0	WP 0033 00 (16 pgs)	0	WP 0069 00 (4 pgs)	0
WP 0001 00 (6 pgs)	1	WP 0034 00 (2 pgs)	0	WP 0070 00 (4 pgs)	1
WP 0002 00 (12 pgs)	0	WP 0035 00 (6 pgs)	0	WP 0071 00 (4 pgs)	1
WP 0003 00 (8 pgs)	0	WP 0036 00 (12 pgs)	0	WP 0072 00 (2 pgs)	0
Chp 2 title page	0	WP 0037 00 (4 pgs)	0	WP 0073 00 (4 pgs)	0
WP 0004 00 (4 pgs)	0	WP 0038 00 (2 pgs)	0	WP 0074 00 (4 pgs)	0
WP 0005 00 (26 pgs)	0	WP 0039 00 (2 pgs)	0	WP 0075 00 (4 pgs)	0
WP 0006 00 (30 pgs)	0	WP 0040 00 (4 pgs)	0	WP 0076 00 (2 pgs)	0
WP 0007 00 (8 pgs)	0	WP 0041 00 (2 pgs)	0	WP 0077 00 (2 pgs)	0
Chp 3 title page	0	WP 0042 00 (4 pgs)	0	WP 0078 00 (2 pgs)	0
WP 0008 00 (2 pgs)	0	WP 0043 00 (8 pgs)	0	WP 0079 00 (2 pgs)	0
WP 0009 00 (4 pgs)	0	WP 0044 00 (4 pgs)	0	WP 0080 00 (4 pgs)	1
WP 0010 00 (4 pgs)	0	WP 0045 00 (2 pgs)	0	WP 0081 00 (4 pgs)	0
WP 0011 00 (4 pgs)	0	WP 0046 00 (8 pgs)	0	WP 0082 00 (4 pgs)	1
WP 0012 00 (4 pgs)	0	WP 0047 00 (4 pgs)	0	WP 0083 00 (4 pgs)	0
WP 0013 00 (2 pgs)	0	WP 0048 00 (12 pgs)	0	WP 0084 00 (4 pgs)	0
WP 0014 00 (2 pgs)	0	WP 0049 00 (2 pgs)	0	WP 0085 00 (2 pgs)	1
WP 0015 00 (4 pgs)	0	WP 0050 00 (2 pgs)	0	WP 0086 00 (4 pgs)	0
WP 0016 00 (4 pgs)	0	WP 0051 00 (2 pgs)	0	WP 0087 00 (2 pgs)	0
WP 0017 00 (2 pgs)	0	WP 0052 00 (4 pgs)	0	WP 0088 00 (2 pgs)	1
WP 0018 00 (2 pgs)	0	WP 0053 00 (2 pgs)	0	WP 0089 00 (2 pgs)	0
WP 0019 00 (2 pgs)	0	WP 0054 00 (4 pgs)	0	WP 0090 00 (4 pgs)	0
WP 0020 00 (2 pgs)	0	WP 0055 00 (2 pgs)	0	WP 0091 00 (2 pgs)	0
WP 0021 00 (2 pgs)	0	WP 0056 00 (8 pgs)	0	WP 0092 00 (2 pgs)	0
WP 0022 00 (2 pgs)	0	WP 0057 00 (4 pgs)	0	WP 0093 00 (4 pgs)	0
WP 0023 00 (2 pgs)	0	WP 0058 00 (4 pgs)	0	WP 0094 00 (2 pgs)	0
WP 0024 00 (2 pgs)	0	WP 0059 00 (8 pgs)	0	GLOSSARY (2 pgs)	0
WP 0025 00 (2 pgs)	0	WP 0060 00 (8 pgs)	0	INDEX-1 - INDEX-8	0
WP 0026 00 (2 pgs)	0	WP 0061 00 (20 pgs)	0	FOLDOUT (2 pgs)	0
WP 0027 00 (2 pgs)	0	WP 0062 00 (10 pgs)	0		
WP 0028 00 (2 pgs)	0	WP 0063 00 (2 pgs)	0		
WP 0029 00 (2 pgs)	0	WP 0064 00 (2 pgs)	0		
WP 0030 00 (4 pgs)	0	Chp 5 title page	0		

HEADQUARTERS,
DEPARTMENT OF THE ARMY
WASHINGTON, D.C., 5 MARCH 2007

TECHNICAL MANUAL

OPERATOR'S AND UNIT MAINTENANCE MANUAL
INCLUDING REPAIR PARTS AND SPECIAL TOOLS LIST (RPSTL)

FOR

SPACE HEATER, CONVECTIVE 60K BTU (SHC-60K)

NSN 4520-01-520-6477

REPORTING ERRORS AND RECOMMENDING IMPROVEMENTS

You can help improve this manual. If you find any mistakes or if you know of a way to improve the procedures, please let us know. Mail your letter or DA Form 2028 (Recommended Changes to Publications and Blank Forms), located in the back of this manual, directly to: TACOM Life Cycle Management Command, ATTN: AMSTA-LC-SECT, Kansas Street, Natick, MA 01760-5052. You may also send in your recommended changes via electronic mail or by fax. Our fax number is DSN 256-5205 or Commercial 508-233-5205. Our e-mail address is soldier.pubs@us.army.mil. A reply will be furnished to you.

DISTRIBUTION STATEMENT A— Approved for public release; distribution is unlimited.

TABLE OF CONTENTS

	<u>WP Sequence No.</u>
WARNING SUMMARY	
HOW TO USE THIS MANUAL	
CHAPTER 1 - DESCRIPTION AND THEORY OF OPERATION	
General Information.....	0001 00
Equipment Description and Data.....	0002 00
Theory Of Operation.....	0003 00
<hr/>	
CHAPTER 2 - OPERATOR INSTRUCTIONS	
Description and Use of Operator Controls and Indicators.....	0004 00
Operation Under Usual Conditions - Preparation For Use.....	0005 00
Operation Under Usual Conditions.....	0006 00
Operation Under Unusual Conditions.....	0007 00

CHAPTER 3 – TROUBLESHOOTING PROCEDURES

Troubleshooting Index.....	0008 00
Troubleshooting Procedures - BATTERY CHARGED indicator does not light	0009 00
Troubleshooting Procedures - BATTERY CHARGING indicator does not light.....	0010 00
Troubleshooting Procedures - Black smoke from heater exhaust.....	0011 00
Troubleshooting Procedures - Exhaust fumes in shelter.....	0012 00
Troubleshooting Procedures - Fault Code 1 – Low battery voltage	0013 00
Troubleshooting Procedures - Fault Code 2 – Combustion fan blower motor	0014 00
Troubleshooting Procedures - Fault Code 3 – No flame	0015 00
Troubleshooting Procedures - Fault Code 4 – Burner maintenance	0016 00
Troubleshooting Procedures - Fault Code 5 – Glow plug	0017 00
Troubleshooting Procedures - Fault Code 6 – TEG over-temperature	0018 00
Troubleshooting Procedures - Fault Code 7 – Over voltage	0019 00
Troubleshooting Procedures - Fault Code 8 – Tip-over	0020 00
Troubleshooting Procedures - Fault Code 9 – Fin temp sensor.....	0021 00
Troubleshooting Procedures - Fault Code 10 – Tent over temperature.....	0022 00
Troubleshooting Procedures - Fault Code 11 – Low system voltage.....	0023 00
Troubleshooting Procedures - Fault Code 12 – Inlet air over-temperature	0024 00
Troubleshooting Procedures - Fault Code 14 – Fuel solenoid	0025 00
Troubleshooting Procedures - Fault Code 15 – Fuel pump/manual thermostat reset.....	0026 00
Troubleshooting Procedures - Fault Code 16 - Vent motor.....	0027 00
Troubleshooting Procedures - Fault Code 17 – Inlet air temperature sensor	0028 00
Troubleshooting Procedures - Fault Code 18 – Battery temperature sensor.....	0029 00
Troubleshooting Procedures - Heater fails to start.....	0030 00
Troubleshooting Procedures - Heater produces rumbling noise.....	0031 00

CHAPTER 4 – MAINTENANCE INSTRUCTIONS

Service Upon Receipt.....	0031 01
Preventive Maintenance Checks and Services (PMCS) Introduction	0032 00
Preventive Maintenance Checks and Services (PMCS)	0033 00
Operator Maintenance Procedures	0034 00
Sediment Strainer.....	0035 00
Burner Assembly	0036 00
Flame Sensor	0037 00
Glow Plug	0038 00
Duct Adapter	0039 00
Unit Maintenance Procedures.....	0040 00
In-tent Controller Assembly	0041 00
In-tent Controller Assembly Cable	0042 00
Battery Pack Assembly	0043 00
Load Bank	0044 00
Fuel Quick Disconnect	0045 00
Fuel Solenoid Valve and Sediment Strainer.....	0046 00
Fuel Hose	0047 00
Electronics Box Assembly, Complete with Wire Harness	0048 00
Dust Cover Assembly.....	0049 00
Combustion Air Blower Assembly	0050 00
Combustion Air Blower Hose	0051 00
Upper Housing Assembly.....	0052 00
Exhaust Grommet	0053 00
Heated Air Blower Assembly.....	0054 00
Inlet Air Temperature Sensor	0055 00
Fuel Pump Assembly	0056 00

CHAPTER 4 – MAINTENANCE INSTRUCTIONS - CONTINUED

Manual Thermostat Reset Switch	0057 00
Internal Fuel Lines.....	0058 00
Float Assembly.....	0059 00
Burner Assembly	0060 00
Thermoelectric Generator	0061 00
Heat Exchanger.....	0062 00
Lower Housing Assembly.....	0063 00
Return And Supply Ducts	0064 00

CHAPTER 5 - SUPPORTING INFORMATION

References.....	0065 00
Maintenance Allocation Chart (MAC) Introduction	0066 00
Maintenance Allocation Chart (MAC).....	0067 00
Repair Parts And Special Tools List (RPSTL) Introduction	0068 00
RPSTL Group 1 In-tent Controller System	0069 00
RPSTL Group 2 Battery Pack System	0070 00
RPSTL Group 3 External Fuel System Components	0071 00
RPSTL Group 4 Electronic Box Assembly Complete with Wire Harness	0072 00
RPSTL Group 5 Dust Cover Assembly	0073 00
RPSTL Group 6 Combustion Blower Assembly	0074 00
RPSTL Group 7 Upper Housing Assembly	0075 00
RPSTL Group 8 Exhaust Grommet	0076 00
RPSTL Group 9 Duct Adapters	0077 00
RPSTL Group 10 Heated Air Blower Assembly	0078 00
RPSTL Group 11 Inlet Air Temperature Sensor.....	0079 00
RPSTL Group 12 Internal Fuel System.....	0080 00
RPSTL Group 13 Burner Assembly and Related Components.....	0081 00
RPSTL Group 14 Thermoelectric Generator (TEG).....	0082 00
RPSTL Group 15 Heat Exchanger	0083 00
RPSTL Group 16 Lower Housing Assembly	0084 00
RPSTL Group 17 Air Supply and Return Ducts with Debris Grill	0085 00
RPSTL Group 18 Spares, Tools, Accessories	0086 00
RPSTL Group Bulk.....	0087 00
National Stock Number (NSN) Index.....	0088 00
Part Number Index	0089 00
Components Of End Item (COEI) List & Basic Issue Items (BII) List.....	0090 00
Additional Authorization List.....	0091 00
Expendable And Durable Items List.....	0092 00
Torque Limits.....	0093 00
Mandatory Replacement Parts.....	0094 00
Glossary	GLOSSARY-1
Alphabetical Index	INDEX-1
Foldout	FP-1

HOW TO USE THIS MANUAL

This manual contains General Information, Operating Instructions, Operator Preventive Maintenance Checks and Services (PCMS), Troubleshooting, and Maintenance/Repair instructions for the Space Heater, Convective 60K BTU (SHC-60K) .

Chapter 1 contains introductory information on the SHC-60K and its associated equipment as well as a Theory of Operation. Chapter 2 includes operating instructions under usual and unusual conditions. Chapter 3 contents cover heater troubleshooting. Chapter 4 contents include PMCS and maintenance instructions. Chapter 5 contains references and other supporting information. Chapter 5 also includes the Repair Parts and Special Tools List (RPSTL) which identifies those parts or tools which are unique to the operation and maintenance of this equipment.

Manual Organization and Page Numbering System. The manual is divided into seven major chapters that detail the topics mentioned above. Within each chapter are work packages covering a wide range of topics. Each work package is numbered sequentially starting at page 1. The work package has its own page numbering scheme and is independent of the page numbering used by other work packages. Each page of a work package has a page number of the form XXXX YY-ZZ where XXXX is the work package number (e.g. 0010 is work package 10) and YY is the revision number for that work package and ZZ represents the number of the page within that work package. A page number such as 0010 00-1/(2 Blank) means that page 1 contains information but page 2 of that work package has been intentionally left blank.

Text and Illustrations. Descriptive text and procedures are always accompanied by one or more illustrations. The text or procedure will be annotated with find numbers such as “(Figure 1, Item 1)” that correspond to a specific callout on the illustration. In this technical manual, the descriptive text or procedure will always precede the illustration. Therefore, when reading a section in the manual, always look for the accompanying illustration to follow the section.

Finding Information. The Table of Contents permits the reader to find information in the manual quickly. The reader should start here first when looking for a specific topic. The Table of Contents lists the topics contained within each chapter and the Work Package Sequence Number where it can be found.

Example: If the reader were looking for instructions on “Preventive Maintenance Checks and Services”, which is an Operator Maintenance topic, the Table of Contents indicates that Operator Maintenance information can be found in Chapter 4. Scanning down the listings for Chapter 4, “Preventive Maintenance Checks and Services” information can be found in WP 0011 00 (i.e. Work Package 11).

An Alphabetical Index can be found at the back of the manual, and lists specific topics with the corresponding work package.

CHAPTER 1
DESCRIPTION AND THEORY OF OPERATION
SPACE HEATER, CONVECTIVE 60K BTU (SHC-60K)

**OPERATOR'S AND UNIT MAINTENANCE MANUAL
SPACE HEATER, CONVECTIVE 60K BTU (SHC-60K)
NSN 4520-01-520-6477
GENERAL INFORMATION**

SCOPE

Type of Manual

Operator's and Unit Maintenance, including RPSTL.

Part Number and Equipment Name

Part Number 160000 - Space Heater, Convective, 60K BTU.

Purpose of Equipment

Heats Modular Command Post System (MCPS) tents, General Purpose (GP) tents, Tent, Modular, Personnel (TEMPER) tents, or other equivalent enclosures.

MAINTENANCE FORMS, RECORDS, AND REPORTS

Department of the Army forms and procedures used for equipment maintenance will be those prescribed by DA Pam 750-8, The Army Maintenance Management System (tams) Users Manual; DA PAM 738-751, Functional Users Manual for The Army Maintenance Management System - Aviation (TAMMS-A); or AR 700-138, Army Logistics Readiness and Sustainability.

REPORTING EQUIPMENT IMPROVEMENT RECOMMENDATIONS (EIR)

If your heater needs improvement, let us know. Send us an EIR. You, the user, are the only one who can tell us what you don't like about your equipment. Let us know why you don't like the design or performance. If you have Internet access, the easiest and fastest way to report problems or suggestions is to go to <https://aeps.ria.army.mil/aepspublic.cfm> (scroll down and choose the "Submit Quality Deficiency Report" bar). The Internet form lets you choose to submit an Equipment Improvement Recommendation (EIR), a Product Quality Deficiency Report (PQDR) or a Warranty Claim Action (WCA). You may also submit your information using an SF 368 (Product Quality Deficiency Report). You can send your SF 368 via e-mail, regular mail, or facsimile using the addresses/facsimile numbers specified in DA PAM 750-8, The Army Maintenance Management System (TAMMS) Users Manual. We will send you a reply.

CORROSION PREVENTION AND CONTROL (CPC)

Corrosion Prevention and Control of Army materiel is a continuing concern. It is important that any corrosion problems with this item be reported so that the problem can be corrected and improvements can be made to prevent the problem in future items.

While corrosion is typically associated with rusting of metals, it can also include deterioration of other materials, such as rubber and plastic. Unusual cracking, softening, swelling, or breaking of the materials may be a corrosion problem.

If a corrosion problem is identified, it can be reported using Standard Form 368, Product Quality Deficiency Report. Use of key words such as "rust," "deterioration," "corrosion," or "cracking" will insure that the information is identified as a CPC problem. The form should be submitted to the address specified in DA PAM 750-8.

DESTRUCTION OF ARMY MATERIEL TO PREVENT ENEMY USE

For destruction procedures for materiel, refer to TM 750-244-3.

PREPARATION FOR STORAGE OR SHIPMENT

Refer to WP 0006 00 for procedures that ensure safe storage and shipment of the heater.

OFFICIAL NOMENCLATURE, NAMES, AND DESIGNATIONS

Shortened nomenclature is used in this manual to make procedures easier for you to read. A cross-reference between the shortened nomenclature and the official nomenclature is shown in the following table.

Table 1. Nomenclature Reference.

Manual Nomenclature	Official Nomenclature
Heater	Space Heater, Convective, 60K BTU
Tent	Modular Command Post System (MCPS) tents General Purpose (GP) tents Tent, Modular, Personnel (TEMPER) tents
Wick	Burner Vaporizer

LIST OF ABBREVIATIONS/ACRONYMS

AAL	Additional Authorization List	MAC	Maintenance Allocation Chart
AMP	Ampere	MAX	Maximum
BII	Basic Issue Item	MCPS	Modular Command Post System
°C	Degrees Celsius	mm	millimeter
CAGEC	Commercial And Government Entity Code	MSDS	Material Safety Data Sheet
CFM	Cubic Feet per Minute	MTOE	Modified Table of Org and Equipment
cm	Centimeter	MWO	Modification Work Order
COEI	Component of End Item	NBC	Nuclear, Biological, Chemical
CPC	Corrosion Prevention Control	N-m	Newton Meters
DC	Direct Current	PMCS	Preventive Maintenance Checks and Services
ea	Each	POL	Petroleum, Oil and Lubricant
EIR	Equipment Improvement Recommendation	QD	Quick Disconnect
°F	Degrees Fahrenheit	Qty	Quantity
gal	Gallons	Ref	Reference
GFE	Government Furnished Equipment	Reqd	Required
hr	Hour	RPSTL	Repair Parts and Special Tools List
IAW	In Accordance With	TEG	Thermoelectric Generator
ID	Inside Diameter	TMDE	Test, Measurement, Diagnostic Equipment
Illus	Illustrated / Illustration	TOE	Table of Organization and Equipment
in	Inches	U/I	Unit of Issue
in.-lb	Inch-pound	U/M	Unit of Measure
Kg	Kilogram	UOC	Usable On Code
L	liter	V	Volt
lbs	Pounds	VDC	Volt Direct Current
lb-ft	Pound-foot	WP	Work Package

QUALITY OF MATERIAL

Material used for replacement, repair, or modification must meet the requirements of this technical manual. If quality of material requirements are not stated in this manual, the material must meet the requirements of the drawings, standards, specifications, or approved engineering change proposals applicable to the subject equipment.

SAFETY, CARE, AND HANDLING

General Safety

Be alert and note all WARNINGS, CAUTIONS, and NOTES. They appear before appropriate procedures. Be sure you read and understand each of the warnings, cautions, and notes. These provide for safe operation of the equipment, and protect you from injury or death and your equipment from damage.

Handling

Material Safety Data Sheet (MSDS)

Sealed Lead-acid battery (SLAB) Lead-acid (LA) battery.

1. PRODUCT AND MANUFACTURER:

Item Identification: *

MSDS date: 1/8/2004

National Stock Number: 4520-01-493-2796

Type Number:

Weight of Item (pounds):

Common Name: Sealed Lead-acid battery

Item Dimensions (inches):

Contract Number:

Manufacturer's Identification: *

Manufacturer's Name and Address
and ZIP code :

Hawker Energy Products, Inc.
617 North Ridgeview Drive
Warrensburg, MO 64093-9301

2. COMPOSITION OF ITEM:

Hazardous Components (Chemical Name, (Symbol), and [CAS#])	Exposure Limits**		Other Recommended Limits	% by Item Weight
	OSHA PEL	ACGIH		
Lead (Pb) [7439-92-1], and Inorganic Lead compounds	0.05			~40-60
Sulfuric acid (H ₂ SO ₄)[7664-93-9]		1, 3(STEL)		~10-40
Antimony (Sb)[7440-36-0]		0.5		<2
Arsenic (As)[7440-38-2]		0.01		< 0.2

** All values reported in mg/m³ unless otherwise specified.

3. PHYSICAL AND CHEMICAL PROPERTIES: N/A for item

Boiling Point: Melting Point:

Vapor Pressure (mmHg):

Vapor Density (Air=1):

Evaporation Rate (butyl acetate = 1):

Solubility in Water:

Specific Gravity (water=1):

pH:

Odor and Appearance:

4. STABILITY AND REACTIVITY:

Chemical Stability: Stable: X Unstable:

Conditions to avoid: Do Not abuse, mutilate or short circuit the battery. Do Not overcharge.

Incompatibility: Incompatible with alkali materials. Store in separate stacks from hazardous materials.

Hazardous Decomposition Products: When exposed to extreme heat/fire batteries may rupture leaking corrosive material and/or emit toxic fumes. Burning batteries may emit toxic fumes of lead, and oxides of sulfur.

Hazardous Polymerization: May Occur: Will not Occur: X
Conditions to avoid:

5. HEALTH HAZARD IDENTIFICATION: Emergency Overview (including **Signs** and **Symptoms, Route(s) of Entry**, etc.): Intact batteries present no specific hazards.

Acute Health Hazards (e.g., Inhalation, Eye Contact, Skin Contact, Ingestion, etc.):

Burning batteries: AVOID inhalation of toxic fumes. Burning batteries emit toxic fumes, which are irritating to the lungs, and may affect the blood, central nervous system, and kidney.

Leaking batteries: AVOID exposure to leaking electrolyte, it can cause severe irritation and/or damage to the skin, mucous membrane or eyes.

Chronic Health Effects (e.g., Carcinogenicity, Teratology, Reproduction, Mutagenicity, etc.):

Lead is a confirmed animal carcinogenic agent. Arsenic is a known carcinogenic agent. Sulfuric acid is a suspected carcinogenic agent.

Medical Conditions Generally Aggravated by Exposure: None.

6. FIRST AID MEASURES:

Inhalation: If battery is burning, leave the area immediately. If exposed to fumes, seek medical attention promptly.

Skin Contact: If battery electrolyte leaks on to the skin flush the affected area for at least 15 minutes with clean water. DO NOT attempt to neutralize. Seek medical attention promptly.

7. FIRE FIGHTING and EXPLOSION HAZARD DATA:

Flammable Properties: N/A

Flashpoint: Method:

Autoignition Temperature:

Flammable Limits: N/A

Lower flammable limit: Upper flammable limit:

Hazardous Combustion Products: Burning batteries may emit toxic fumes of lead, and oxides of sulfur.

Extinguishing Media: Carbon dioxide (CO₂) or dry chemical fire extinguisher.

Fire Fighting Instructions:

Personnel: Fight the fire in a defensive mode, while exiting the area. When using a CO₂ fire extinguisher, DO NOT re-enter the area until it has been thoroughly ventilated (i.e., purged) of the CO₂ extinguishing agent.

Firefighters: Use a self-contained breathing apparatus (SCBA).

8. ACCIDENTAL RELEASE MEASURES:

Small Spill: DO NOT use finely divided combustibles materials (e.g., sawdust) for cleaning up spills. If

batteries show signs of leaking, AVOID skin or eye contact with the material leaking from the battery. Isolate spill ONLY if can be done safely. Use chemical resistant rubber gloves and non-flammable absorbent materials for clean-up. Coordinate disposition with the Installation Environmental Office.

9. HANDLING AND STORAGE:

Hazardous Characteristic Code: Z4

Handling: Recharge batteries IAW methods specified in applicable technical manuals. DO NOT:

- Overcharge this battery.
- Abuse, mutilate or short circuit the battery.
- Attempt to Drain sealed batteries.

Storage: Store batteries IAW DLAI 4145.11(TM 38-410), Storage and Handling of Hazardous Materials, Chapter 4, Section H. Gain approval for storage areas from the Installation Fire Department. Store batteries in a cool (i.e., <130°F), dry and well ventilated area. Protect batteries from freezing. DO NOT:

- Store batteries in direct sunlight or under hot conditions.
- Smoke and keep batteries away from open flame or heat.
- Store batteries in the same stacks with other hazardous materials,
- Store batteries in office areas, or other areas where personnel congregate.

Work/Hygienic Practices: Thoroughly wash hands after cleaning-up a battery spill (i.e., leaking or venting batteries). NO eating, drinking or smoking in battery storage areas.

10. EXPOSURE CONTROL/PERSONAL PROTECTION EQUIPMENT:

Engineering Controls:

General Exhaust: Local Exhaust:

Special: If the battery is damaged and leaking, protect hands with chemical resistant rubber gloves. If the battery is burning, leave the area immediately.

Protective Equipment :

Respiratory Protection: During fire fighting firemen should use SCBA.

Skin Protection: Use chemical resistant rubber gloves, when cleaning-up leaking batteries.

11. DISPOSAL CONSIDERATIONS/ECOLOGICAL INFORMATION:

Waste Disposal Method: DO NOT incinerate

1. Lead-acid batteries are hazardous waste (HW) (i.e., D002 and D008) under Resource Conservation and Recovery Act (RCRA) regulations. All batteries will be managed IAW equipment TM requirements, and disposal/recycling will be IAW requirements under the Universal Waste Rule (i.e., USEPA regulations), state and local regulations.

2. These batteries should be recycled, if possible. Coordinate battery disposition and disposal with the Installation Environmental Office and the servicing Defense Reutilization and Marketing Office.

12. TRANSPORTATION INFORMATION: Lead-acid batteries are regulated under the federal hazardous materials provisions of 49 Code of Federal Regulations (CFR) for transportation.

Applicable Regulation: 49 CFR parts 172.101 and 173.159

DOT Proper Shipping Name: Batteries, wet, non-spillable, electric storage

DOT Hazard class: 8

DOT Identification Numbers: UN2800

DOT Packaging Group (PG): III

DOT Label codes: 8

Procedures: Package and ship batteries IAW DOT regulations. Securely package batteries to

withstand conditions normal to shipping. Protect batteries against short circuiting.

Special Precautions: Isolate and remove damaged and/or leaking batteries, if this can be done safely. If necessary leave immediate area to a safe distance from the spill. Notify local health, safety and environmental agencies.

Lead-Acid batteries are a Hazardous Waste (HW). A Material Safety Data Sheet (MSDS) is required for any battery turned-in for recycling or disposal. Batteries may be recycled or disposed through the local servicing Defense Reutilization and Marketing Office (DRMO), or Hazardous Waste Manager via local contract. Recycling and/or reclamation is the recommended option for disposition of Lead-acid batteries in lieu of disposal. Batteries may not be thrown away as ordinary trash.

The DRMO/Hazardous Waste Manager will accept batteries that are properly marked, labeled, packaged, and turned in for recycling or disposal with appropriate MSDS documentation.

Coordinate all recycling or disposal actions with the local Installation Environmental Office or Hazardous Waste Manager to ensure proper management of batteries as Hazardous Waste. All recycling or disposal actions MUST BE in accordance with local, state, Installation, and federal regulations and requirements.

For additional information on the proper recycling or disposal of batteries, refer to Technical Bulletin 43-0134, Battery Disposal and Disposition.

CAUTION

DO NOT accumulate or store waste batteries for disposal for more than 90 days.

**OPERATOR'S AND UNIT MAINTENANCE MANUAL
SPACE HEATER, CONVECTIVE 60K BTU (SHC-60K)
NSN 4520-01-520-6477
EQUIPMENT DESCRIPTION AND DATA**

EQUIPMENT CHARACTERISTICS, CAPABILITIES, AND FEATURES

The Modular Command Post System (MCPS) tents, General Purpose (GP) tents, Tent, Modular, Personnel (TEMPER) tents, Modular General Purpose Tent System (MGPTS), hereafter referred to as the tent, require a heat source. This heater fulfills the need for an independent, powerful, self-powered, self-sustaining, self-regulating, self-diagnostic heater.

The in-tent control assembly (with controls, visual advisory lights, and an audible alarm) must be mounted inside the tent and a control cable (remote) used to connect the tent control assembly to the heater.

The operation of the heater is controlled by the ON-OFF switch and the LOWER-HIGHER control knob (both located on the control assembly), and the heater control assembly (located within the heater itself).

Manual movement of the ON/OFF switch to the ON position will cause the heater to automatically execute a series of steps that lead to heater operation. Manual movement of the ON/OFF switch to the OFF position will cause the heater to automatically execute a safe and orderly shutdown.

The status of the heater assembly can be determined by looking at the advisory lights on the tent control assembly or by listening to the audible alarm. These lights and the related audible alarm are controlled by the heater control assembly, which monitors the normal operation of heater, and, when an abnormal operating condition is detected, cause the heater to shut off. Also, when an abnormal operating condition is detected, the SYSTEM FAULT advisory light and the integral audible alarm are activated and pulse out the following SYSTEM FAULT diagnostic codes:

Table 1. System Fault Diagnostic Codes.

Number of Pulses and Audible Tones	System Fault
1	LOW BATTERY VOLTAGE
2	COMBUSTION FAN BLOWER MOTOR
3	NO FLAME
4	BURNER MAINTENANCE
5	GLOW PLUG
6	TEG OVER TEMPERATURE
7	OVER VOLTAGE
8	TIP-OVER
9	FIN TEMP SENSOR
10	TENT OVER TEMPERATURE
11	LOW SYSTEM VOLTAGE
12	INLET AIR OVER TEMPERATURE
13	NOT USED
14	FUEL SOLENOID
15	FUEL PUMP OR MANUAL THERMOSTAT RESET
16	VENT MOTOR
17	INLET AIR TEMPERATURE SENSOR
18	BATTERY TEMPERATURE SENSOR

JP-8 is the preferred fuel for all temperature conditions. It burns cleaner than other fuels and will provide the best heater performance. JP-8 use will reduce the frequency of required burner maintenance. Diesel fuel use will necessitate regular burner cleaning every 750 to 1000 hours. Approved alternate fuels are listed in Table 2 below.

Table 2. Approved Fuels.

	Ambient Temperature	Specification	Military Symbol
Primary Fuel	Above -60 °F (-51.1 °C)	MIL-T-83133	JP-8
Alternate Fuels	Above -60 °F (-51.1 °C)	VV-F-800	DF-A
	Above -60 °F (-51.1 °C)		K-1
	Above -25 °F (-31.7 °C)	MIL-T-83133	JP-5
	Above -25 °F (-31.7 °C)	VV-F-800	DF-1
	Above +20 °F (-6.7 °C)	VV-F-800	DF-2

Characteristics and Capabilities

- Axial flow self-contained fully automatic heater system.
- Four person carry, one person set-up and operation.

Capabilities and Features

- Provides 60,000 BTU/Hour maximum output
- Automatic high-low fire cycles.
- In-tent thermostatic control.
- Runs on JP-8 as well as standard diesel fuels.
- Self-charging electrical system – no external power required in normal operation.

LOCATION AND DESCRIPTION OF MAJOR COMPONENTS

The following are the major components of the Space Heater, Convective, 60K BTU (SHC-60K). A brief description of the function of each component and its location is detailed below.

In-Tent Controller Assembly

The in-tent control assembly (**Figure 1, Item 1**) contains the operator controls and advisory lights for the heater. The in-tent control assembly is a remotely wired, splashproof box that can be easily attached to the tent framework. The in-tent controller assembly is only intended for use inside the tent.

Operating Instructions Plate

Operating instructions plate (**Figure 1, Item 2**) is provided on the in-tent control assembly (**Figure 1, Item 1**).

In-Tent Controller Cable Assembly

An in-tent controller cable assembly (**Figure 1, Item 3**) is used to connect the in-tent controller assembly (**Figure 1, Item 1**) to the heater.

Battery Pack Assembly

The battery pack assembly (**Figure 1, Item 4**) consists of two 12-V sealed lead-acid, non-spillable batteries with an integral electrical heating element. Each 12-volt battery is composed of six 2V DC cells in series. Each battery is rated at 5 amp-hours for a total of 10 amp-hours. The battery pack assembly location is clearly marked and is located in a recess (**Figure 1, Item 5**) below the lower housing assembly. Two fuse holders (**Figure 1, Item 6**) carrying 20 amp fuses are incorporated into the side of the battery pack. Two spare fuses (**Figure 1, Item 7**) are located on the fan housing at the breathable air inlet end of the heater.

The battery (**Figure 1, Item 4**) is used for burner ignition, and to power the control system until the thermoelectric generator (TEG) (**Figure 4, Item 8**) generates power. The battery is recharged during heater operation by the TEG. Depending on battery condition and temperature, the battery has an approximate 30-minute recharge time.

If battery (**Figure 1, Item 4**) temperatures are below 40°F (4.4°C), it is electrically heated by an integral heating element. When the battery reaches 60°F (15.6°C), this heating element is shut off by the controller.

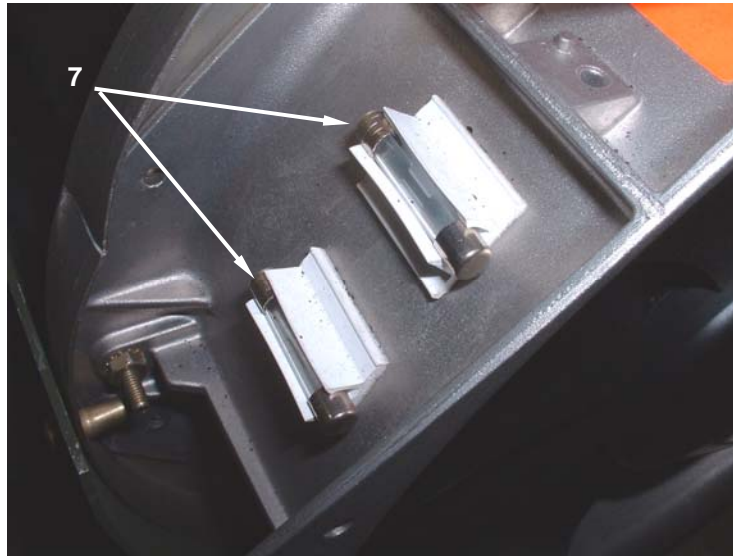
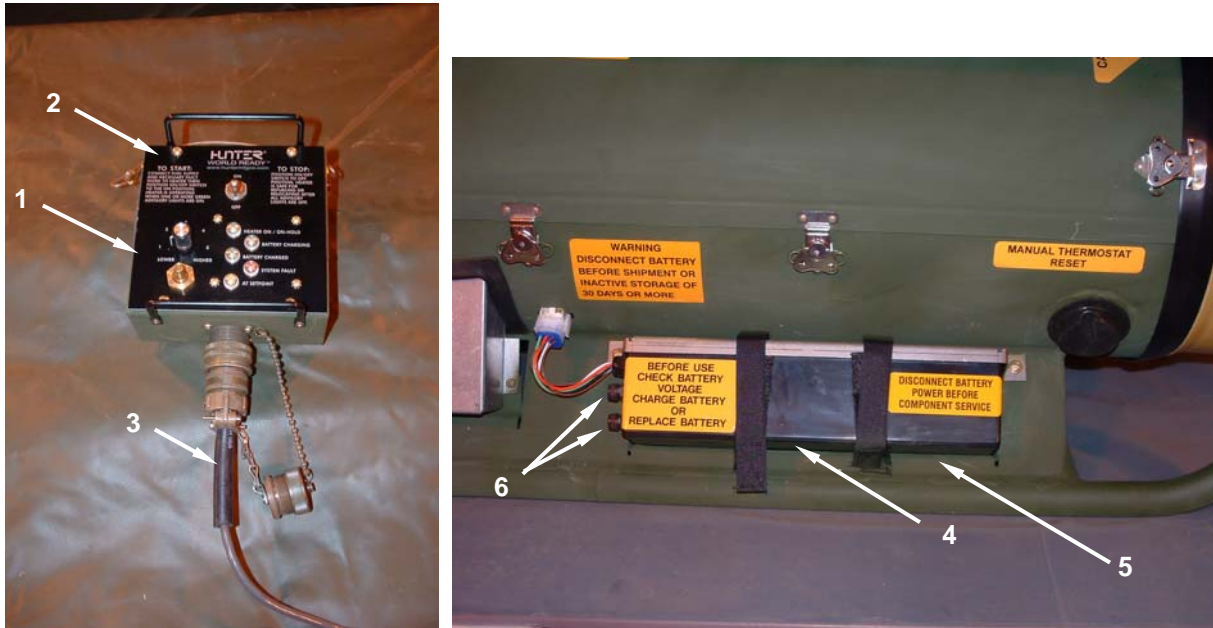

Figure 1. Space Heater Convective (SHC) 60K BTU External Components.

Combustion Air Inlet Assembly

The combustion air inlet assembly (**Figure 2, Item 9**) is connected to the combustion air blower located inside the heater and is the source of outside air used for combustion by the burner assembly.

Upper Housing Assembly

The upper housing assembly (**Figure 2, Item 10**) consists of a compartment cover assembly having certain hardware and connections mounted on it.

Lower Housing Assembly

The frame and heater housing are welded together to form the lower housing assembly (**Figure 2, Item 11**).

Fuel Solenoid Valve Assembly

The fuel solenoid valve assembly (**Figure 2, Item 12**) has a normally closed valve, which opens to allow fuel to enter the heater when the ON/OFF switch (**Figure 2, Item 13**) is in the ON position. The solenoid valve is closed when the switch is turned OFF or if heater control assembly detects a SYSTEM FAULT condition.

Fuel Quick Disconnect

A fuel quick disconnect (**Figure 2, Item 14**) is located at the inlet side of the fuel solenoid valve assembly (**Figure 2, Item 12**). This military style male fitting has a protective dust cap connected to it for use when the heater is not connected to the fuel supply.

Air Supply Duct with Debris Grill

The air supply duct (**Figure 2, Item 15**) with debris grill (**Figure 2, Item 16**) conducts air from the tent to heater assembly for warming. This duct is 12 inches in diameter and has a debris grill to prevent accidental entry of foreign objects into the heater assembly. A strap is used to connect the duct to the heater inlet. Note that upon initial shipment, the debris grill is not installed in the duct. The debris grill must be installed in the duct prior to using the heater IAW WP 0005.

An airflow direction arrow tag is permanently attached to the duct indicating that the flow of air moves from the debris grill end of the duct to the open end that connects to the heater.

Air Return Duct with Debris Grill

The air return duct (**Figure 2, Item 17**) with debris grill (**Figure 2, Item 18**) conducts heated (breathable) air from the heater assembly to tent. This duct is 12 inches in diameter and has a debris grill to prevent accidental entry of foreign objects into the heater assembly. A strap is used to connect the duct to the heater outlet duct adapter. Note that upon initial shipment, the debris grill is not installed in the duct. The debris grill must be installed in the duct prior to using the heater IAW WP 0005.

An airflow direction arrow tag is permanently attached to the duct indicating that the flow of air moves from the open end that connects to the heater to the debris grill end of the duct that is installed in the tent duct tunnel.

Accessory Bag

An accessory bag (**Figure 3, Item 19**) is provided to permit stowage of all loose SHC-60K items such as the air inlet and return ducts (**Figure 2, Items 15 and 17**), in-tent controller assembly (**Figure 2, Item 13**) and cable (**Figure 3, Item 20**), battery charging adapter (**Figure 2, Item 21**), two gravity feed adapters (**Figure 2, Item 22**), Y adapter (**Figure 2, Item 23**), fuel hose (**Figure 2, Item 24**), and fuel can stand (**Figure 2, Item 25**).

Heater Transport Bag

A heater transport bag (**Figure 3, Item 26**) is provided for safe transport and storage of the SHC-60K.

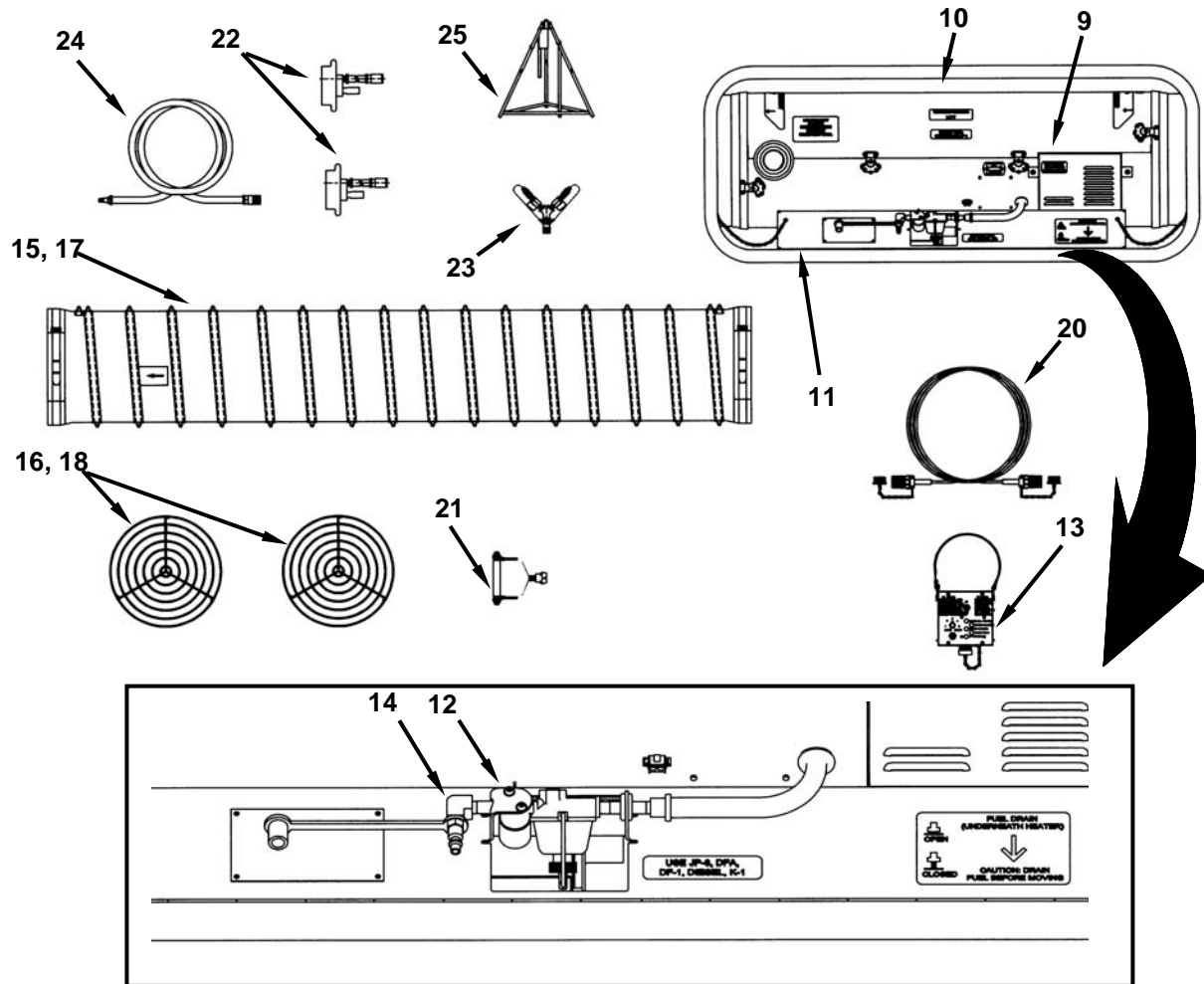

Figure 2. Space Heater Convective (SHC) 60K BTU External Components – Continued.



Figure 3. Space Heater Convective (SHC) 60K BTU External Components – Accessory Bag and Components

Burner Assembly

The burner assembly (**Figure 4, Item 27**) consists of a vaporization type burner. The burner assembly uses a glow plug (**Figure 4, Item 28**) for starting and requires no power other than the combustion blower (**Figure 4, Item 29**) and the fuel pump (**Figure 4, Item 30**) to operate. During starting, the main control board (**Figure 4, Item 31**) directs 11.5 V DC from the battery to the glow plug to initiate startup. An external fuel drain (**Figure 4, Item 32**) is also provided under the float assembly to facilitate draining the fuel system.

Main Control Board

The main control board (**Figure 4, Item 31**) uses information from the heater's sensors and the tent control assembly to determine the ideal firing rate. The air/fuel ratio is adjusted as needed to maintain the ideal firing rate.

The main control board (**Figure 4, Item 31**) is housed on a printed circuit board and located on the lower housing next to the battery compartment and is clearly marked. The main control board manages the distribution of power throughout the Space Heater Convective. It includes temperature and tilt sensors and the control circuit. The control circuit analyzes information from the sensors to maintain the optimum firing rate for the heater. To maintain the firing rate, it controls the rates of fuel flow and air flow, and continuously monitors the in-tent control assembly settings to verify that the desired settings are reached.

The main control board also controls system startup and shutdown, and monitors the heater safety systems. If a fault is detected, it immediately begins the shutdown procedure and signals the operator that a fault has occurred.

Combustion Air Blower

The combustion air blower assembly (**Figure 4, Item 29**) integrates a 12-volt direct current (DC) combustion air fan located in the lower heater housing. The combustion air blower draws air through the combustion air inlet (**Figure 4, Item 33**) and passes it through a flexible hose (**Figure 4, Item 34**) to the burner assembly (**Figure 4, Item 27**).

Heated Air Blower Assembly

A heated air blower assembly (**Figure 4, Item 35**) is mounted behind the duct adapter (**Figure 4, Item 36**). It features a 12-volt DC fan in series at the inlet end of the heater. The fan moves approximately 500 cubic feet per minute (CFM) of heated, breathable air when operating.

The heated air blower assembly (**Figure 4, Item 35**) forces fresh air or air removed from the tent through the heater. This air passes across the TEG and the heat exchanger, where it absorbs heat and is directed into the tent.

Since the heater is designed to provide a variable British Thermal Units per hour (BTU/HR) output and still maintain internal generation of system and battery electricity, the heater needs to regulate between being a heater and being a generator of electricity as operational requirements change. This electronic marriage of components allows for a safe and smooth transition from generation of electricity to heating. The selection of a sophisticated controller reduces the amount of training required to operate the heater and provides continuous monitoring and control of the heater.

Fuel Pump

The fuel pump (**Figure 4, Item 30**) is controlled by frequency pulses from the heater control assembly and is responsible for supplying fuel to the burner assembly.

Heat Exchanger

The heat exchanger (**Figure 4, Item 37**) transfers heat from hot gases produced by the burner to the heated (breathable) air. The heated air runs over the outside of the heat exchanger to collect the heat. This heated (breathable) air is then used to heat the tent. The heat exchanger is sandwiched between the upper housing assembly and the lower housing assembly. The heat exchanger provides an outlet and mounting flange for the combustion exhaust pipe (**Figure 4, Item 38**) and an O-ring seal and gasket (**Figure 4, Item 39**). The hot combustion gases inside the heat exchanger are exhausted outside the enclosure through the combustion exhaust pipe.

Thermoelectric Generator

The thermoelectric generator (TEG) (**Figure 4, Item 8**) provides electrical power to operate the heater system and recharge the battery. Once the TEG is operating at full power, it supplies enough energy to operate the heater assembly and maintain a battery charging voltage of 14.5 volts. When the battery pack has been fully charged, the extra energy the TEG creates is converted into heat and used to heat the shelter.

The TEG includes a mantle which directs the hot gases exiting the burner assembly to evenly heat the inside diameter (ID) of the TEG. This improves the ability of the TEG to generate electrical power.

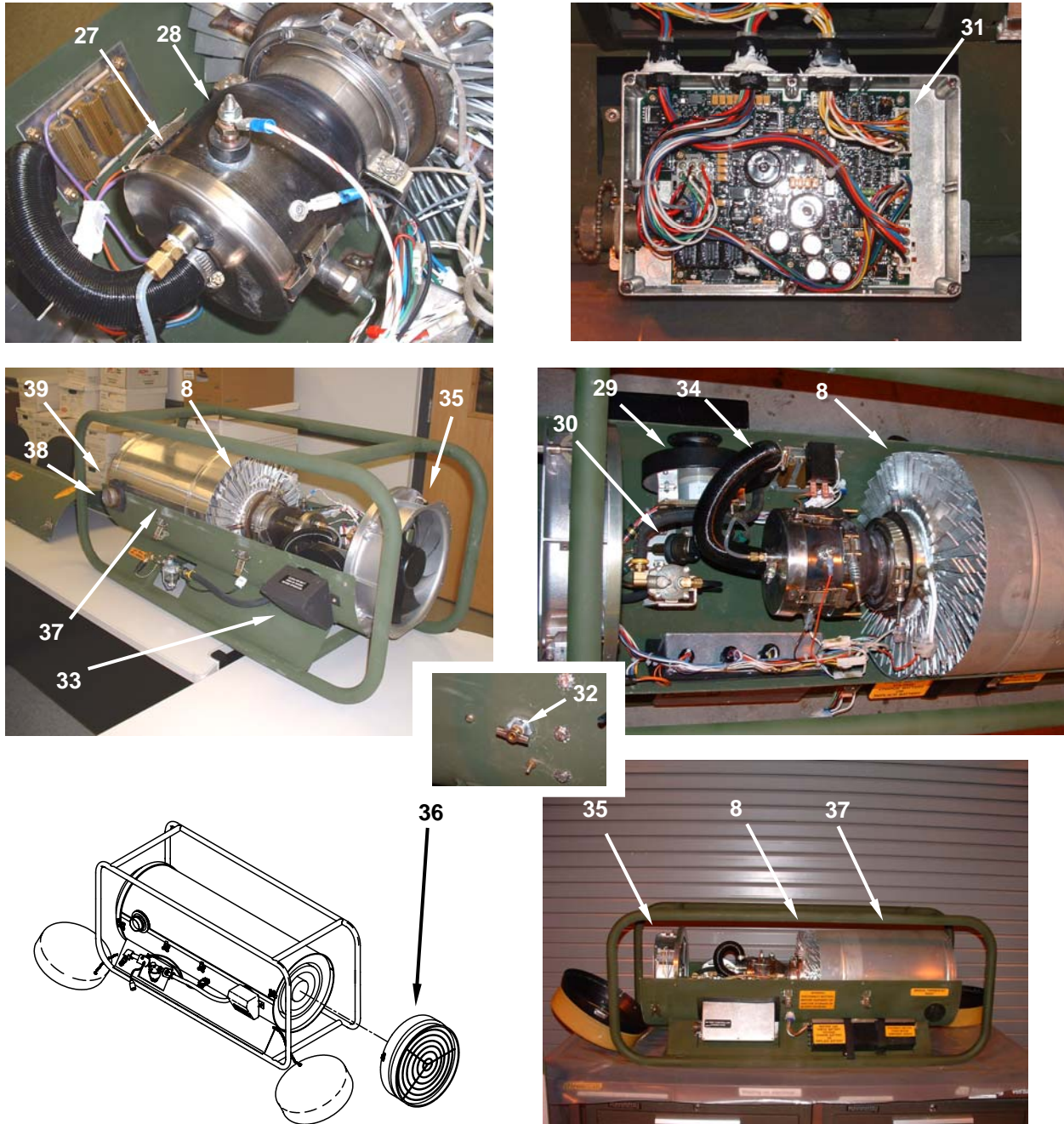

Figure 4. Space Heater Convective (SHC) 60K BTU Internal Components.

Onboard Spares and Tools

In addition to the foregoing major components, each space heater, convective package includes onboard spares and/or tools listed in Table 4. All the spares are stored behind the duct adapter at the end of the heater labeled "Breathable Air Inlet". The wrench is located adjacent to the combustion air blower, and the battery charging adapter is stored in the Accessory Bag.

Table 4. Onboard Spares and Tools.

Item	Name	Qty	Item	Name	Qty
1	Flame sensor	1	5	Sediment Strainer Gasket	1
2	Glow plug	1	6	Sediment Strainer Screen	1
3	Wrench	1	7*	Battery charging adapter	1
4	Battery pack fuses 20 amp	2			

* Battery charging adapter stored in accessory bag.



Figure 5. Onboard Spares and Tools.

ADDITIONAL EQUIPMENT REQUIRED FOR USE WITH THIS HEATER

The 5 gallon (18.9 L) fuel can, listed on the AAL, provides a fuel source during heater operation.

EQUIPMENT DATA

Table 5. Equipment Data.

Manufacturer	Hunter Manufacturing Company
Part number	160000
Operating temperature range	+65°F(+18.3°C) -60°F (-51.1 °C)
BTU/Hr (automatically variable)	
Low	50,000
High	65,000
Efficiency	75-82%
Electrical system	10.50-14.75 volts DC
Glow plug	11.5 volts DC (Starting only)
Fuses, Spare Battery Pack – 20 amp	2 each
Battery Pack Fuses – 20 Amp	2 each
Combustion air fan	12 volt DC EMB INDUSTRIES
Air flow	
Heated air (breathable) high fire rate	500 CFM
Heated air temperature rise	140°F (60°C)
Maximum at duct debris grill	350°F (115°C)
Combustion air outlet temperature (exhaust)	500-700°F (260-371°C)
Heater dimensions (without accessories)	
Length	47.75 inches (121 cm)
Width	17.12 inches (43.5 cm)
Height	19 inches (48.26 cm)
Heater volume	9.0 cubic feet (0.2550 m ³)
Heater weight (without accessories)	100 pounds (45.7 Kg)
Fuel requirements:	
Primary Fuel	
Above -60°F (-51.1°C)	*MIL-T.83 133 (JP-8)
Approved Alternate Fuels	
Above -60°F (-51.1°C)	VV-F-800 (DF-A)
Above -25°F (-31.7°C)	Kerosene (K-1)
Above -25°F (-31.7°C)	MIL-T-83133 (JP-5)
Above -25°F (-31.7°C)	VV-F-800 (DF-1)
Above +20°F (-6.7°C)	VV-F-800 (DF-2)
Fuel consumption	1.6 hours/gal. (maximum) 1.9 hours/gal. (average)
Minimum safe distance to combustibles	2 feet
Battery pack (with heater)	1 each
Type	Starved electrolyte (gel cell)
Rating	
Burner assembly	
Glow plug	11.5-12 volts
All other electrical components	12-24 volts
Manufacturer	Gates
Thermoelectric generator (TEG)	
Manufacturer	Global
Type	Lead telluride (vacuum sealed)
Rating	210 watts, 15 amps

*JP-8 is the primary fuel source for the Space Heater Convective (SHC) 60K BTU.

OPERATOR'S AND UNIT MAINTENANCE MANUAL
NSN 4520-01-520-6477
SPACE HEATER, CONVECTIVE 60K BTU (SHC-60K)
THEORY OF OPERATION

The SHC-60K (**Figure 1, Item 1**) is installed outside the tent with its air supply (**Figure 1, Item 2**) and return (**Figure 1, Item 3**) ducts routed through pass-through sleeves (**Figure 1, Item 4**) located in the side of the tent (**Figure 1, Item 5**). Fuel cans (**Figure 2, Item 1**) mounted on a fuel can stand (**Figure 2, Item 2**) feed fuel to the space heater by means of gravity feed adapters (**Figure 2, Item 3**), a Y adapter (**Figure 2, Item 4**) and a fuel hose (**Figure 2, Item 5**). The fuel hose is connected to the SHC-60K by means of a quick disconnect connector (**Figure 1, Item 6**).

All SHC-60K functions are controlled via the in-tent controller assembly (**Figure 2, Item 6**) which hangs inside the tent. An in-tent controller assembly cable (**Figure 2, Item 7**) is connected between the in-tent controller assembly and the heater in order to control all heater operations from inside the tent.

Placing the ON/OFF switch (**Figure 2, Item 8**) of the in-tent controller (**Figure 2, Item 6**) in the ON position sends a signal to the power control assembly (**Figure 1, Item 7**) energizing the system. At this point the "heater on/on-hold" advisory light (**Figure 2, Item 9**) on the in-tent controller illuminates indicating the heater has begun operation.



Figure 1. SHC-60K Installed Outside of Tent.

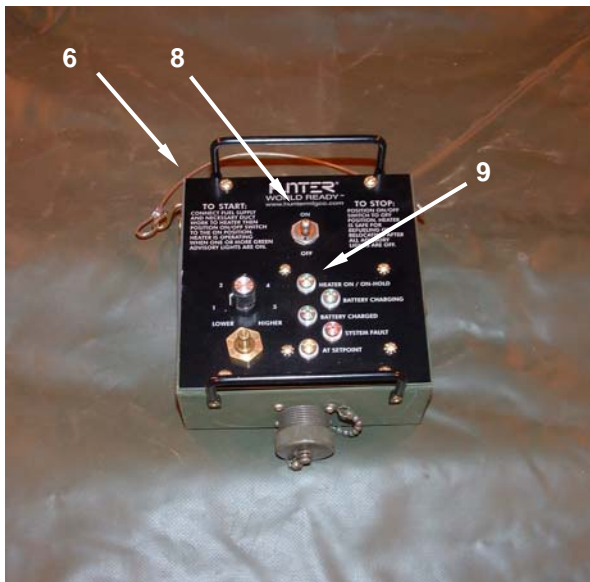

Figure 2. SHC-60K Fuel Can, Controller Assembly and Cable.

A 12-volt battery pack assembly (**Figure 3, Item 1**) is used to supply power to the power control assembly (**Figure 3, Item 2**) and facilitates burner ignition until the thermoelectric generator (TEG) (**Figure 3, Item 3**) begins generating power. The power drawn from the battery pack assembly is replaced by the TEG while the heater delivers heat to the shelter.



Figure 3. SHC-60K Power Control, Battery Pack and TEG.

Once power is applied to the system, the power control assembly (**Figure 3, Item 2**) sends a signal to the fuel solenoid valve (**Figure 4, Item 1**), opening the valve and allowing fuel to flow through the sediment strainer (**Figure 4, Item 2**) to the float assembly (**Figure 4, Item 3**). Fuel is then pumped in short pulsating bursts by the fuel pump (**Figure 4, Item 4**) to the burner assembly (**Figure 4, Item 5**) where it is vaporized. The heater control assembly controls all electrical functions, including system startup, shutdown, and safety checks. It includes temperature and tilt sensors and the control circuit. The control circuit analyzes information from the sensors to maintain the optimum firing rate for the heater. To maintain the firing rate, it controls the rates of fuel and air flow, and continuously monitors the in-tent controller assembly settings to verify that the desired settings are reached.

The control system also controls system startup and shutdown, and monitors the heater safety systems. If a fault is detected, it immediately begins the shutdown procedure and signals the operator that a fault has occurred.

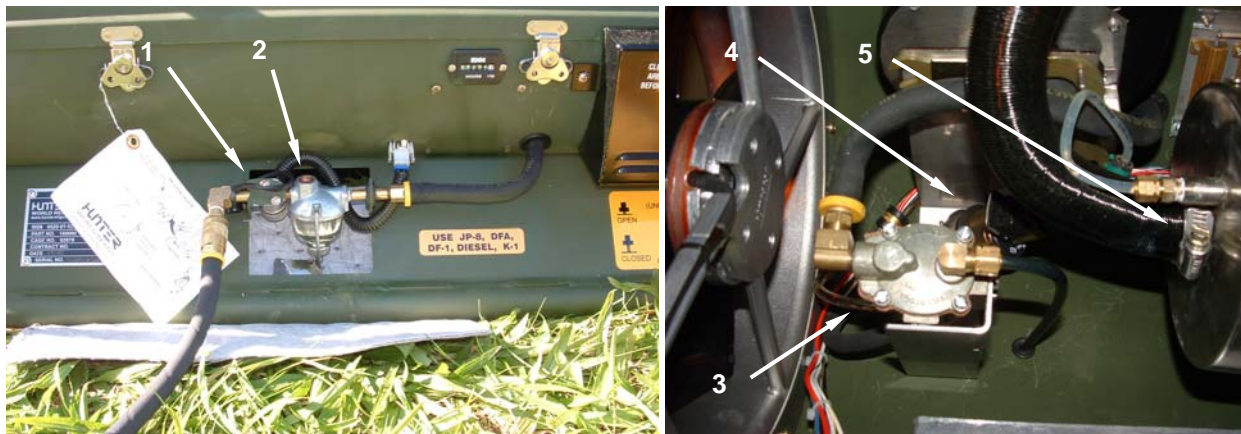

Figure 4. SHC-60K Power Control Assembly and Fuel Components.

Once fuel enters the burner assembly (Figure 5, Item 1), power is drawn from the battery pack (Figure 5, Item 2), and applied to the glow plug (Figure 5, Item 3) igniting the fuel. The TEG (Figure 5, Item 4) converts heat into electricity which is used to recharge the battery pack. When the battery pack is charging, the “battery charging” advisory light (Figure 5, Item 5) on the in-tent controller assembly illuminates. The heater continues to run as the battery pack recharges.

When the battery pack (Figure 3, Item 1) is fully recharged, the “battery charged” advisory light (Figure 5, Item 6) on the in-tent controller assembly illuminates and the “battery charging” light (Figure 5, Item 5) extinguishes. The battery can go into recharge mode during operation if necessary and does not need to be fully charged to operate.

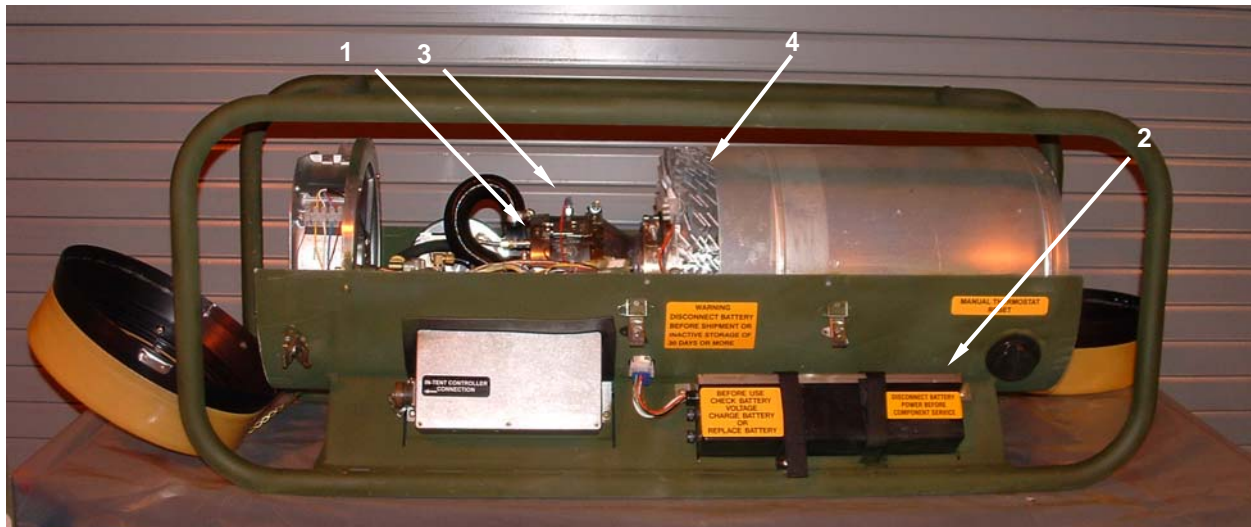

Figure 5. SHC-60K Indicator Lights.

At this point, the heated air blower assembly (**Figure 6, Item 1**) is engaged and cold air is drawn from the shelter through the breathable air inlet (**Figure 6, Item 2**) and forced through the heat exchanger (**Figure 6, Item 3**) at the outlet end of the heater. The shelter air is heated and forced out the air return duct (**Figure 6, Item 4**) into the shelter as heated air.

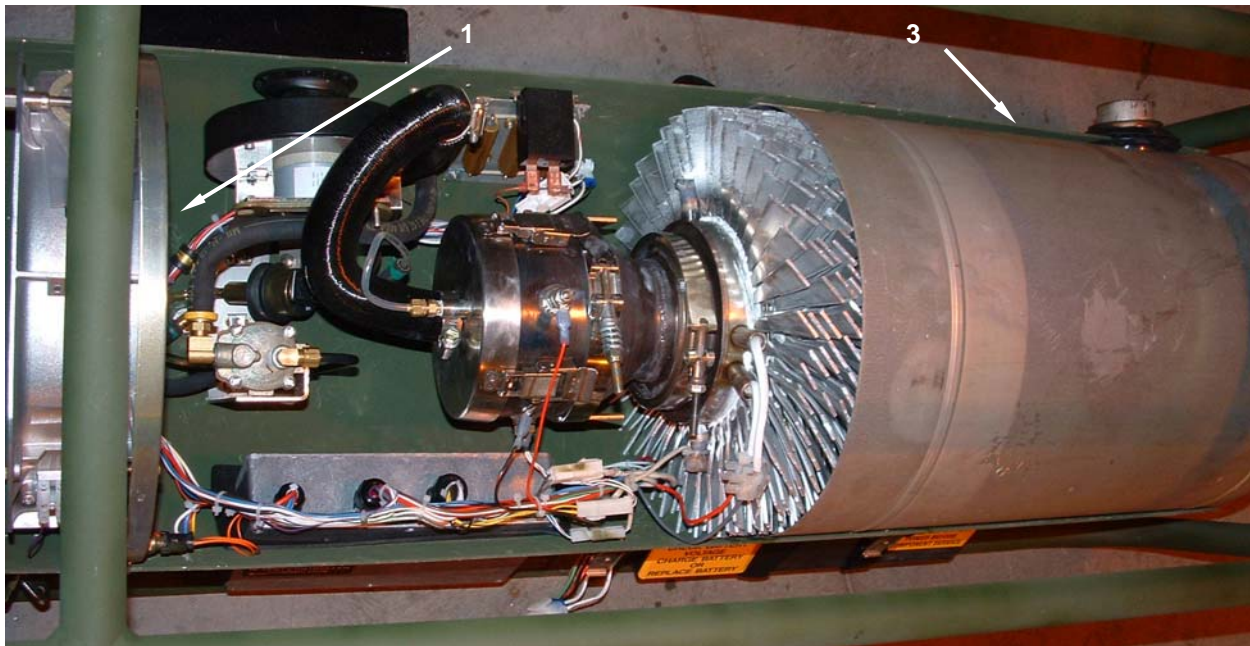

Figure 6. SHC-60K Heater Exchange Process.

As heated air is supplied to the shelter, the temperature inside the shelter rises. This temperature is monitored by a sensor (**Figure 7, Item 1**) on the in-tent controller assembly. When the shelter temperature reaches the value set on the “lower/higher” control (**Figure 7, Item 2**) of the in-tent controller assembly, a signal is sent to the heater, and the burner assembly (**Figure 7, Item 3**) will not completely shut down but will toggle between high and low fire condition. Air continues to circulate through the shelter via the heated air blower assembly (**Figure 7, Item 4**) and the “At Setpoint” advisory light (**Figure 7, Item 5**) illuminates.

Once the temperature inside the shelter drops below the set point, the burner (**Figure 7, Item 3**) switches to a high fire condition and supplies more heated air to the shelter.

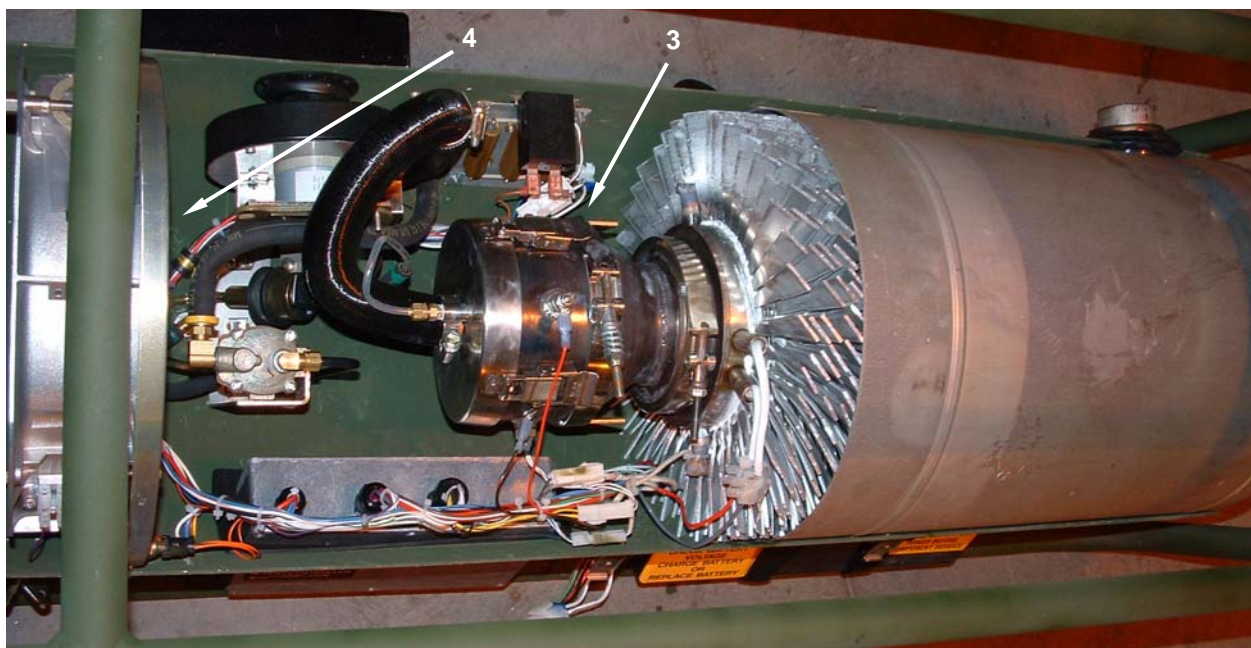
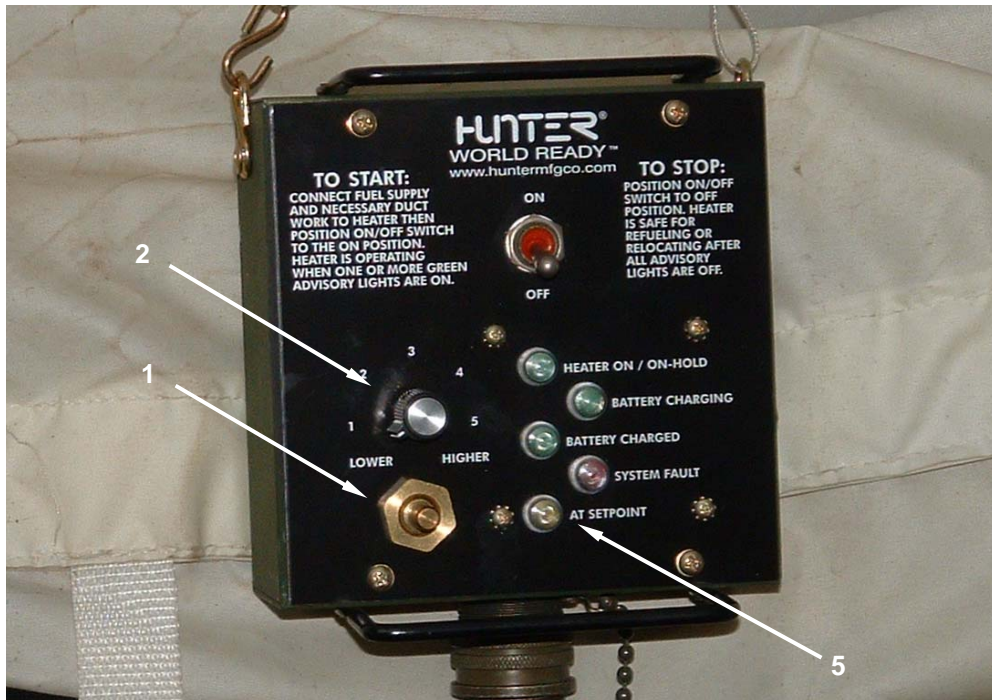

Figure 7. SHC-60K Temperature Change Indicators.

Heater operation is terminated by switching the ON/OFF switch (Figure 8, Item 1) on the in-tent controller to the OFF position. The fuel solenoid valve (Figure 8, Item 2) is closed and all fuel flow to the burner assembly (Figure 8, Item 3) ceases. When all advisory lights are extinguished, the heater is shut down and can be moved or left in place for another operational cycle.

If a system fault occurs during operation, the power control assembly (Figure 8, Item 4) monitors this condition and sends a signal to the in-tent controller illuminating the "System Fault" advisory light (Figure 8, Item 5) on the in-tent controller.

An inlet air temperature sensor (Figure 8, Item 6) is located on the heated air blower assembly (Figure 8, Item 7) of the heater. If the air temperature is above 62.2°F the heater will go into low fire, if the temperature falls below 58.2°F the heater will go into high fire to bring the air temperature up.

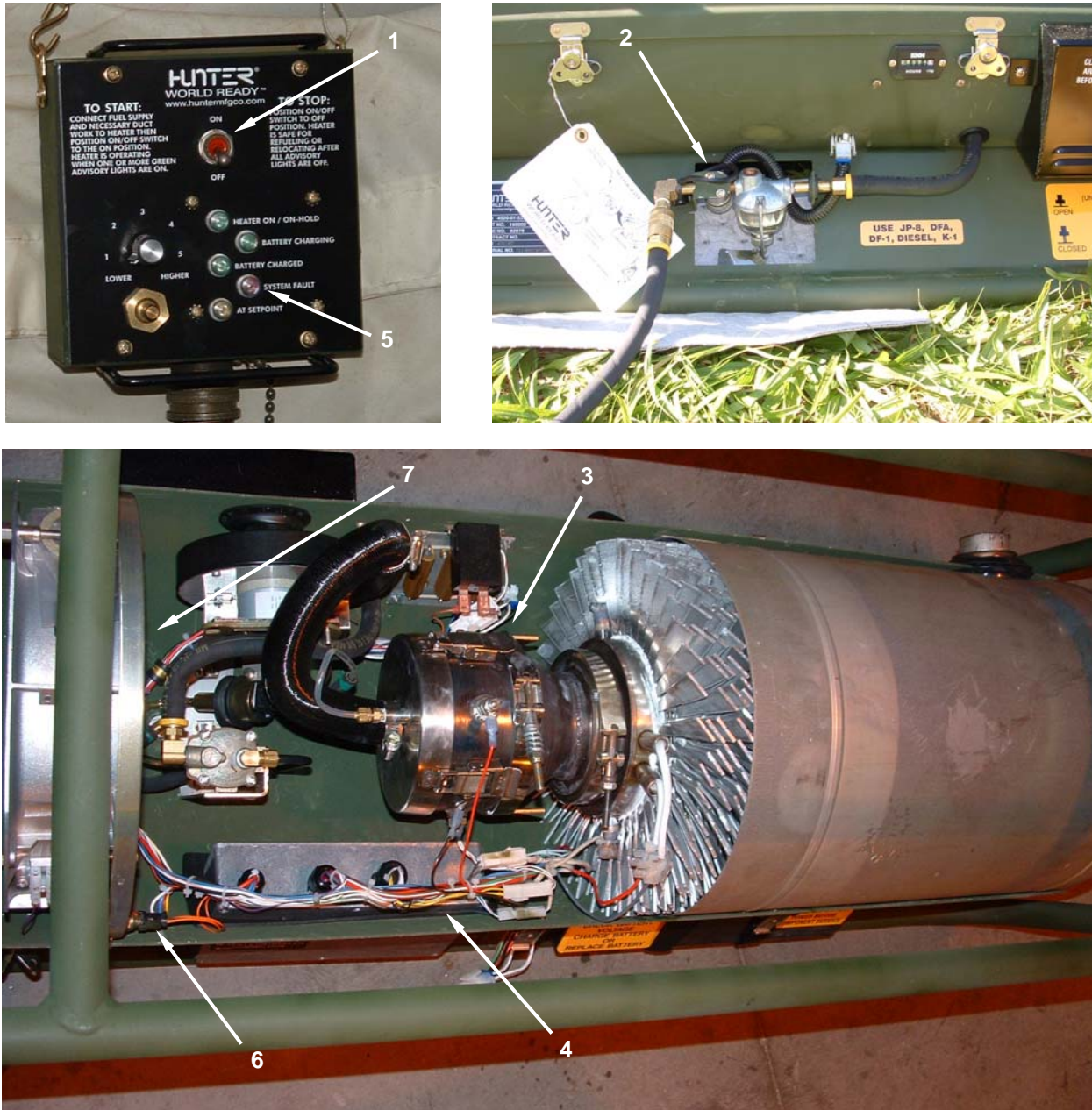

Figure 8. SHC-60K Low Fire and High Fire.

CHAPTER 2
OPERATOR INSTRUCTIONS
SPACE HEATER, CONVECTIVE 60K BTU (SHC-60K)

**OPERATOR'S AND UNIT MAINTENANCE MANUAL
SPACE HEATER, CONVECTIVE 60K BTU (SHC-60K)
NSN 4520-01-520-6477
DESCRIPTION AND USE OF OPERATOR CONTROLS AND INDICATORS**

GENERAL

This section contains information on the controls and indicators located on the Space Heater, Convective, 60K BTU.

Before operating the heater, the user must become familiar with the controls and indicators provided on the unit. The operating controls are installed on the in-tent control assembly (**Figure 1, Item 1**) and the manual reset thermostat (**Figure 1, Item 2**) is on the lower housing assembly.

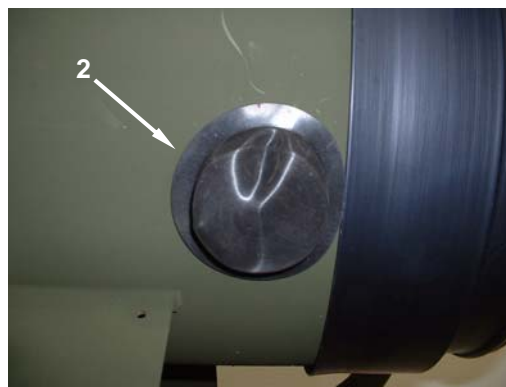

Figure 1. Controls and Indicators.

HEATER CONTROLS AND INDICATORS

The description and function of the controls and indicators of the in-tent controller assembly are detailed in Table 1 and supported by the illustration in Figure 2. The manual reset thermostat switch located on the lower housing assembly is described in Table 2 and supported by the illustration in Figure 3.

Table 1. In-Tent Control Assembly Controls and Indicators.

Key	Name	Function
1	ON-OFF switch	Controls starting and stopping of the heater. Movement of the ON/OFF switch from one position to another initiates the step-by-step transition of the heater from one operating condition to another (the OFF condition to the ON condition, or the ON condition to the OFF condition). This step-by-step transition is controlled and timed by the heater control assembly, and not by the movement of the ON/OFF switch.
2	HEATER ON/ON-HOLD light (green)	When lit, indicates the heater assembly is in one of the following modes: 1) post-purge, 2) normal operation, 3) on-hold. The on-hold mode indicates that the heater is going through initial starting procedures.
3	LOWER/HIGHER control knob	Controls the setpoint that the heater is trying to reach, thereby controlling the heat output of the heater. Adjusting the control knob causes the heater assembly to provide higher or lower heat outputs to the tent. When the temperature within the tent reaches the setpoint, an amber AT SETPOINT light glows. When the temperature sensor registers this temperature, the heater begins to regulate its output so that the temperature is maintained.
4	BATTERY CHARGING light (green)	When lit, indicates the heater assembly battery is being charged by the TEG. While this light is lit, the heater's electronic controller responds to the LOWER-HIGHER control knob settings.
5	BATTERY CHARGED light (green)	When lit, indicates the heater assembly battery is fully charged and the heater will respond fully to the changes in tent temperature or changes to the LOWER-HIGHER control knob settings. Once this light comes on, the heater can be turned off with assurance that the battery is fully charged and there will be enough power for the next startup.
6	SYSTEM FAULT light (red)	When this advisory light is pulsing and the related audible alarm (also located within the tent control assembly) is beeping, it indicates the heater assembly sensors and the electronic heater control assembly have detected an unsafe operating condition and the heater has begun to shut itself off. This advisory light and audible alarm provide a sequence of from 1 to 18 pulses that correspond to diagnostic codes explaining the cause of SYSTEM FAULT. See back of the heater control assembly for diagnostic codes.
7	AT SETPOINT light (amber)	When lit, indicates the interior tent temperature is at or above the LOWER-HIGHER control setting.

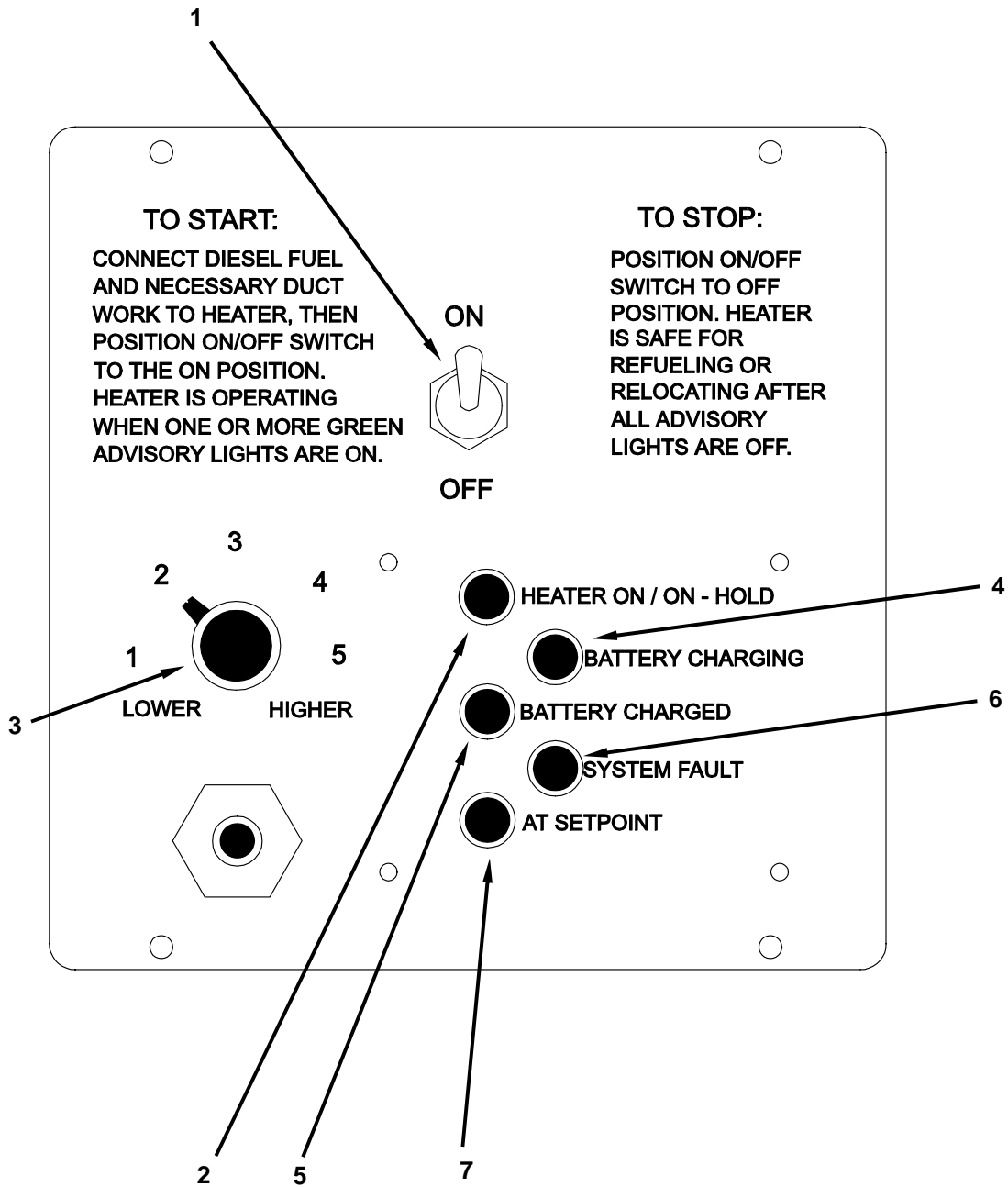

Figure 2. In-Tent Heater Controls and Indicators.

Table 2. Lower Housing Assembly Controls and Indicators.

Key	Name	Function
1	Manual Reset Thermostat Switch	A manual reset thermostat switch comprising a high-temperature cutout with a built-in reset switch is located on the lower portion of the heater housing. Its purpose is to backup the temperature sensors of the heater control system. In a situation where the heat exchanger overheated and the heater controller did not shut down the heater, this manual reset thermostat switch would activate and cut electrical power to the heater fuel pump, shutting down fuel flow and thus causing the heater to shut down with a Fault Code 15. Once the heater is determined to be safe for operation, the manual reset thermostat switch must be reset by pushing the reset switch button located underneath the rubber protector that is located on the heat exchanger end of the heater.
2	Hour Meter	Counts the hours that the Space Heater, Convective 60 K BTU is used.

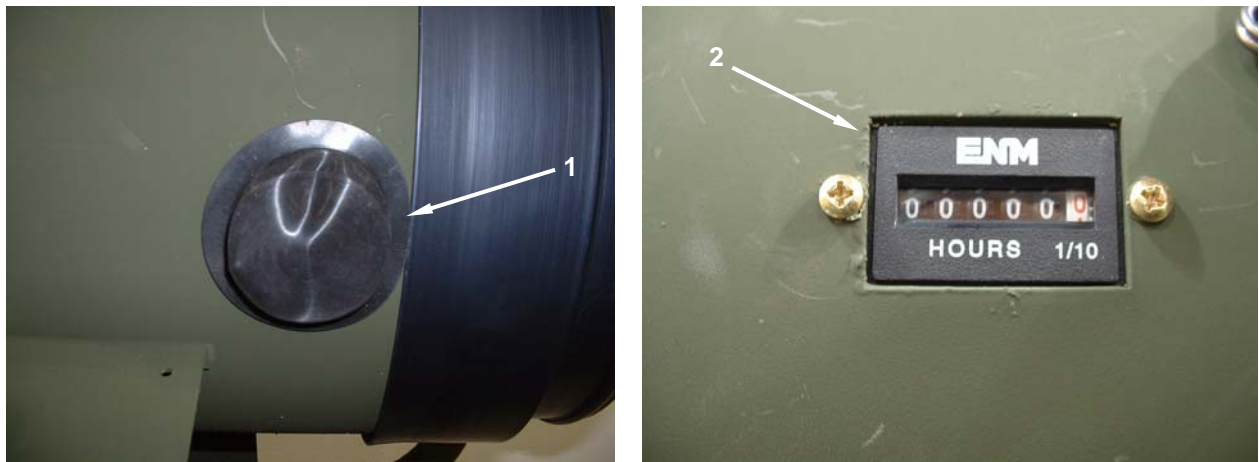

Figure 3. Manual Reset Button and Hour Meter.

**OPERATOR'S AND UNIT MAINTENANCE MANUAL
SPACE HEATER, CONVECTIVE 60K BTU (SHC-60K)
NSN 4520-01-520-6477
OPERATION UNDER USUAL CONDITIONS**

SECURITY MEASURES FOR ELECTRONIC DATA

The SHC-60K requires no special security measures.

PREPARATION FOR USE

Unpacking and Inspection Upon Receipt

Inspect containers and packaging upon receipt for evidence of damage occurring in shipping. The heater package and its accessories were carefully inspected and securely packaged prior to shipment. If damage to the containers or packaging is found it is the shipper's responsibility.

Do not unpack a heater that is obviously damaged in shipment until the shipper is notified and has inspected the packaging. Notify your supervisor.



WARNING

Excessive weight hazard. The Space Heater, Convective 60K BTU (SHC-60K) weighs approximately 118 pounds (53.5 kg) with accessories and transit bag. Four persons must carry the unit, lifting with legs, not back, to prevent injury. Failure to do so may result in serious back or other muscular skeletal injuries.

Remove heater package and accessories from shipping containers and packaging.

Inspect the heater package and accessories for completeness by comparing the contents against the description of the equipment found in the Components of End Item work package of this technical manual.

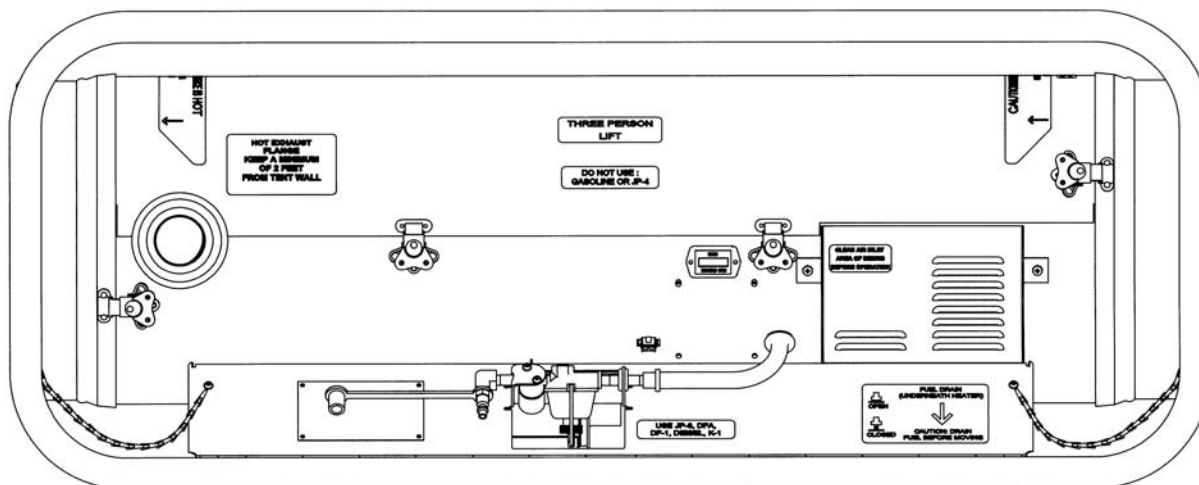

Figure 1. SHC-60K.

TENT WALL MODIFICATION KIT (TWMK) INSTALLATION

In order to operate the SHC-60K, tent duct tunnels must be present on one of the walls of the tent. If none have been fitted, installation of tent duct tunnels must be performed before using the SHC-60K.

If these tunnels are not present on the shelter, the tent wall modification kit (NSN 4520-01-493-3215, Part Number 5-13-5627, CAGEC 92878) must be applied to the tent. Complete instructions for the installation of the tent wall modification are contained in the following section.

NOTE

The entire assembly process can be done from inside the tent.

Tools Required:

- Cutting Tool (knife or razor blade).
- Marking Tool (pen, pencil, or marker).
- Philips Screwdriver.
- Punch (if available).
- Measuring Tape

Components included with kit:

- 2 Plain Rings (**Figure 2, Item 1**).
- 2 Cuff Rings (with fabric attached) (**Figure 2, Item 2**).
- 10 bolts and 10 nuts (**Figure 2, Item 3**).



Figure 2. TWMK components.

Install TWMK

1. To determine the proper location for the installation of the Tent Wall Modification Kit (TWMK), enter the tent and lift up the tent liner (if present) to expose tent wall.
2. Measure approximately 3 ¼ feet from the center of the tent towards a side wall.
3. Measure approximately 12 inches up from the floor and mark an "X".
4. Repeat step 2 and 3 for other side.
5. The distance between the two marked X's should be approx. 6 ½ feet.
6. Place a plain ring around the marked "X" on one side, (center "X" inside Plain Ring).
7. Using a punch, punch a hole through the top hole of the Plain Ring thru the tent material.
8. Place a bolt through that hole to temporarily hold the plain ring in place onto the tent.
9. Continue to punch holes for the remaining five holes as you put in a bolt in each punched hole. (It's important that you put in a bolt after each punched hole to maintain alignment).

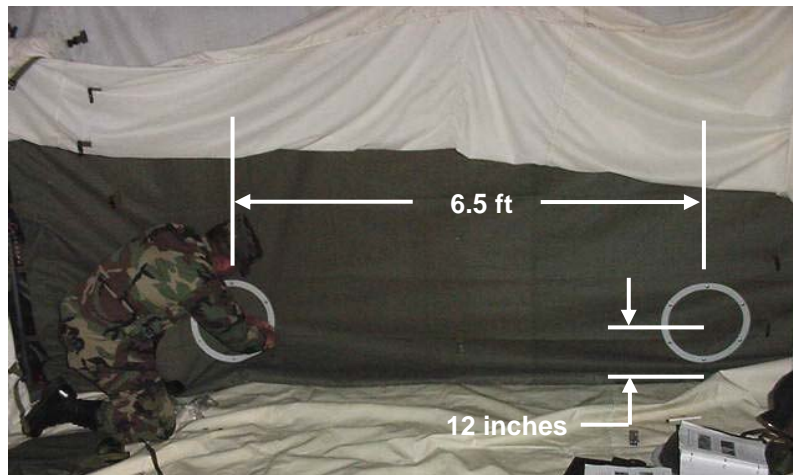

Figure 3. Locate and Begin TWMK Installation.



WARNING

Personnel injury/cuts. Leather glove hand protection must be worn. The use of protective gloves will significantly reduce the risk of cut injury. Failure to do so could result in serious injury to fingers or hands.

10. Once all bolts are in place, using the plain ring as a template, cut out a hole in the tent wall along the inside diameter of the ring (approximately 19" diameter hole).

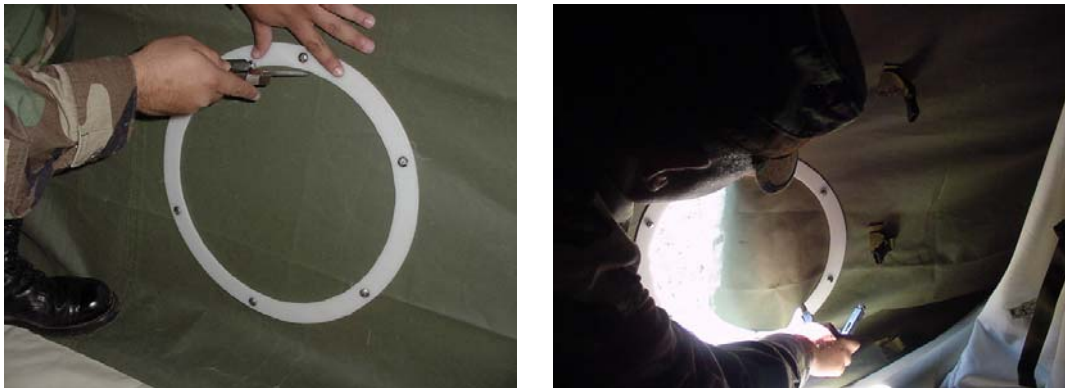

Figure 4. Cut Hole in Tent.

11. Repeat steps 6 thru 10 for the other hole location.
12. Once the large holes have been cut out, remove the plain rings and hardware from the wall.
13. Install a cuff ring where the plain ring was previously located on the inside tent wall with the fabric cuff pushed through to the outside of the tent.
14. Line up and install the bolts through the cuff ring and the tent wall. Use the Philips screwdriver to help in screwing the bolts through the fabric to the outside.
15. Squeeze and push the plain ring through the cuff ring to the outside.



Figure 5. Install TWMK Rings.

16. Line up the plain ring with the protruding bolts.
17. Place and tighten the nuts (6 total) on the protruding bolts outside of tent so as to sandwich the tent wall between the 2 rings.
18. Repeat steps 13 thru 17 for the other hole location.

NOTE

A successful installation should look similar to the photo below.



Figure 6. Complete TWMK Installation.

NOTE

Perform all "Before" PMCS before proceeding.

SITE SELECTION CRITERIA (OUTSIDE THE TENT)**WARNING**

Excessive weight hazard. The Space Heater, Convective 60K BTU (SHC-60K) weighs approximately **118 pounds (53.5 kg)** with accessories and transit bag. Four persons must carry the unit, lifting with legs, not back, to prevent injury. Failure to do so may result in serious back or other muscular skeletal injuries.

NOTE

Testing indicated that the heater may interfere with other electronics equipment in its vicinity. If this occurs, move the electronic equipment away from the heater until interference is no longer a problem.

The SHC-60K site will be dictated by the location of the tent since the heater inlet (**Figure 7, Item 1**) and outlet (**Figure 7, Item 2**) ducts must be able to reach the tent duct tunnels (**Figure 7, Item 3**).

NOTE

Heater will not operate when tilt or grade is greater than 15 degrees, which is a 2.6 foot drop over a 10 foot span.

The heater site must be as level as possible (heater will not start or operate if the slope is greater than 15 degrees), and free of combustible material (e.g. dried twigs, leaves, etc.). If snow is present, it should be removed from the area immediately beneath and around the heater.

The site should be selected so that the heater will be positioned at least 2 feet (61 cm) from combustibles, including the tent wall.



Figure 7. Outside Setup.

Positioning the Heater Outside Tent



WARNING

The heater cannot be placed any closer than two feet to the tent or any other combustible material. Failure to observe this precaution may result in fire, with serious injury or death to personnel.

Place heater on the side of the tent that has the tent duct tunnels (**Figure 8, Item 1**). The heater should be a minimum of 2 feet (61 cm) from tent walls (**Figure 8, Item 2**). Position the heater (**Figure 8, Item 3**) so that the combustion exhaust outlet (**Figure 8, Item 4**) is directed away from the tent wall (**Figure 8, Item 2**) and the two six-foot (183 cm) long ducts (**Figure 8, Item 5**) can be connected to both the heater (**Figure 8, Item 3**) and the tent (**Figure 8, Item 2**). Do not install the ducts or connect the fuel supply at this time, simply place the heater in position.



Figure 8. Positioning Heater Outside of Tent.

PREPARING A FUEL SUPPLY SITE

Select a fuel supply site that is level, free of debris and open flame, at least seven feet (2.13 meters) from the tent, and a minimum of five feet (1.5 meters) from heater.

NOTE

A piece of petroleum absorbent material should be placed where the fuel can and fuel can stand will be installed as well as under the fuel quick disconnect connector in order to catch any fuel that may spill. Additional commercial products are available to contain large spills. Absorbent material that is soiled with fuel/petroleum products shall be discarded in accordance with local environmental regulations.

Route the fuel supply hose from the heater to the fuel supply location to gauge where the fuel supply site is best located. Place a petroleum absorbent mat where the fuel can stand will be set up.

Assemble Fuel Can Stand

Select a site for the fuel can stand (**Figure 9, Item 1**) that is a minimum of 5 feet (1.5 m) but no more than 8 feet (2.4m) from the fuel quick disconnect connector on the heater. The fuel can stand with fuel can should be level or slightly elevated above heater as detailed in the next section. No heat or flame sources, other than the heater, is allowed within 8 feet (2.4 m) of fuel can stand. Set up the fuel can stand in accordance with the instructions detailed below. For convenience in the field, an instruction card with abbreviated procedure is attached to the fuel can stand.



WARNING

Death or serious injury may occur if fuel is not handled carefully. Always place fuel can and stand in well-ventilated area as far away from open flames and other potential ignition sources as possible. Fuel spills shall be cleaned up in accordance with local requirements.



WARNING

Personnel injury/cuts. Leather glove hand protection must be worn. The use of protective gloves will significantly reduce the risk of cut injury. Failure to do so could result in serious injury to fingers or hands.

1. Remove the stand components from the plastic bag (**Figure 9, Item 2**), and retain the bag for packing.
2. Lay out the bottom leg assembly (**Figure 9, Item 3**) and the top leg assembly (**Figure 9, Item 4**) as shown.
3. Orient each bottom leg (**Figure 9, Item 5**) so that the stabilizing strap (**Figure 9, Item 6**) is not twisted. The stabilizing strap is designed to ensure the stand is stable, but are also designed to prevent the stand from sinking into snow.

4. Insert each bottom leg (**Figure 9, Item 5**) into the top leg assembly (**Figure 9, Item 4**) until the leg is locked in place. This may be verified by observing the locking pins (**Figure 9, Item 7**).
5. Spread the fuel can stand (**Figure 9, Item 1**) until the stabilizing strap (**Figure 9, Item 6**) is fully extended and the stand is stable.
6. Lower the support arms (**Figure 9, Item 8**) so that each is at a right angle to its attached leg, and then unfold and lock the support arm extensions (**Figure 9, Item 9**) in place.
7. Place the tripod brace (**Figure 9, Item 10**) under the top bracket (**Figure 9, Item 11**) of the stand and clip into position over the front of the top bracket.

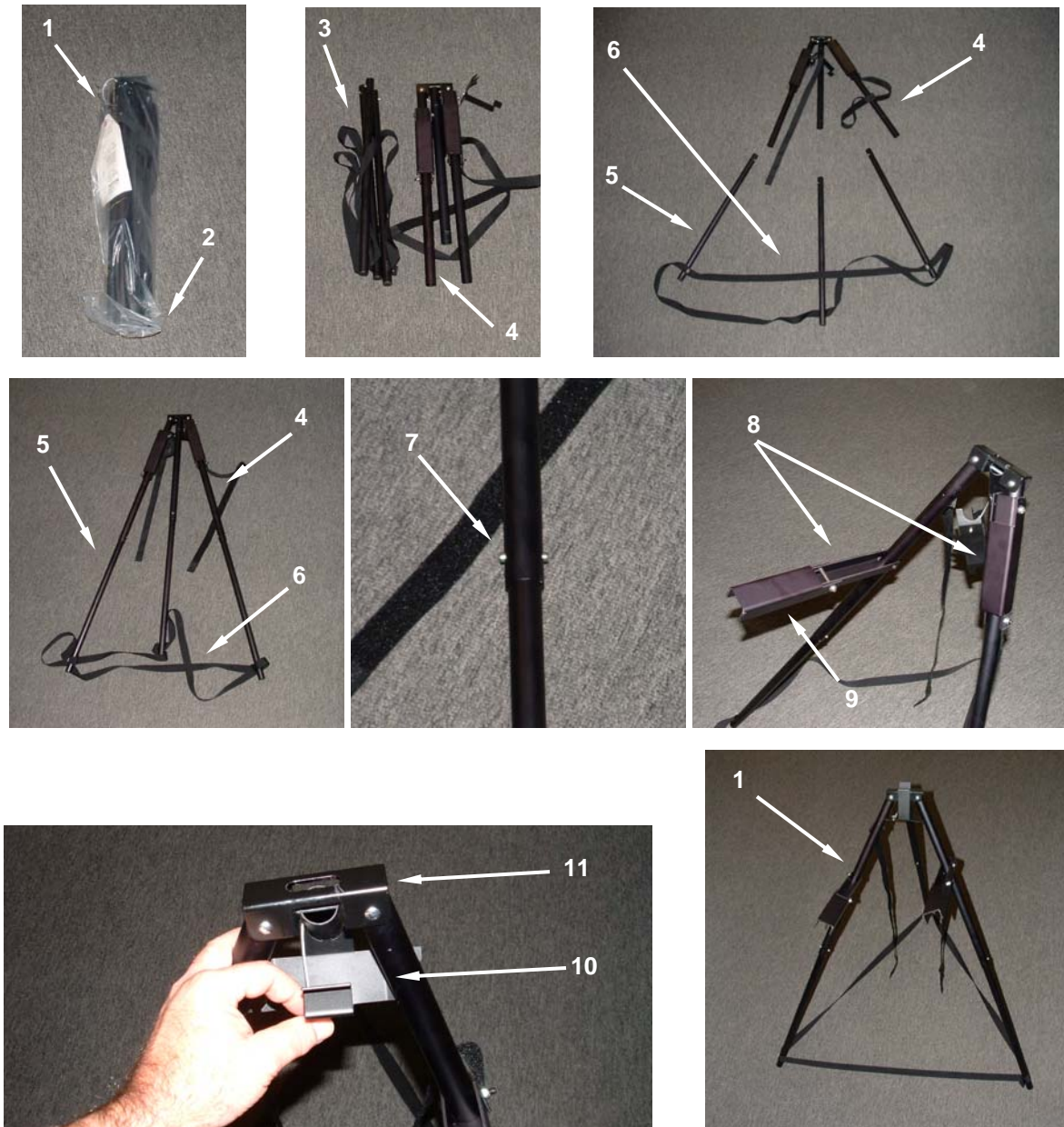

Figure 9. Fuel Can Stand Assembly.

FILL FUEL CAN WITH FUEL AND INSTALL FUEL CAN ADAPTER

Heater Assembly Fuel Selection



WARNING

Fuels are toxic and flammable. Do not refuel near open flame or other ignition sources. Only refuel in a well-ventilated area. Wear eye/face protection, avoiding contact with skin and clothes, and don't breathe vapors. If contact with eyes or skin is made, immediately flush with clean water and get medical aid for eyes. If contact with clothing or skin is made, immediately remove contaminated clothing and clean skin with mild soap or cleanser and flush with clean water.

Always store fuel can in well-ventilated area as far away from open flames and other potential ignition sources as possible. Leaking or spilled fuels will create a fire danger-injuries/death and environmental damage. Fuel spills must be cleaned up in accordance with local requirements.

Failure to observe fuel requirements could cause damage to the heater assembly, fire danger-potential explosion, and injury or death to personnel within or around the tent and the heater assembly.

Gasoline, JP-4, used motor oil, fuel mixtures, solvents or other unauthorized fuels must **NOT** be used with the SHC-60K under any circumstance. Only JP-8 or an approved alternate fuel as detailed in Table 1 may be used. Failure to observe fuel requirements could cause damage to the heater assembly and injury or death to personnel within or around the tent and the heater assembly. Fuel spills shall be cleaned up in accordance with local requirements.

Refer to Table 1 to determine the appropriate fuel for the ambient temperature.

Table 1. Fuel Selection.

	Ambient Temperature	Specification	Military Symbol
Primary Fuel	Above -60 °F (-51.1 °C)	MIL-T-83133	*JP-8
Alternate Fuels	Above -60 °F (-51.1 °C)	VV-F-800	DF-A
	Above -60 °F (-51.1 °C)	MIL-P- 25576	K-1
	Above -25 °F (-31.7 °C)	MIL-T-5624	JP-5
	Above -25 °F (-31.7 °C)	VV-F-800	DF-1
	Above +20 °F (-6.7 °C)	VV-F-800	DF-2

Install Gravity Feed Adapter



WARNING

Gravity feed adapters must be fully seated to prevent fuel leakage, with fire and explosion hazards. Failure to observe this precaution may result in injury or death to personnel in the tent or operating the heater. Leaked or spilled fuel should be cleaned up IAW local requirement in order to prevent personnel, equipment, or environmental hazards.

At the fuel supply site, install a fuel can adapter on a full fuel can as follows:

1. Remove cap (**Figure 10, Item 1**) from mouth (**Figure 10, Item 2**) of fuel can (**Figure 10, Item 3**), and replace with gravity feed adapter (**Figure 10, Item 4**). Screw the adapter into the fuel can securely.

NOTE

Ensure the gravity feed adapter connection is fully seated and secured to avoid leakage.

2. Repeat for the remaining fuel can.

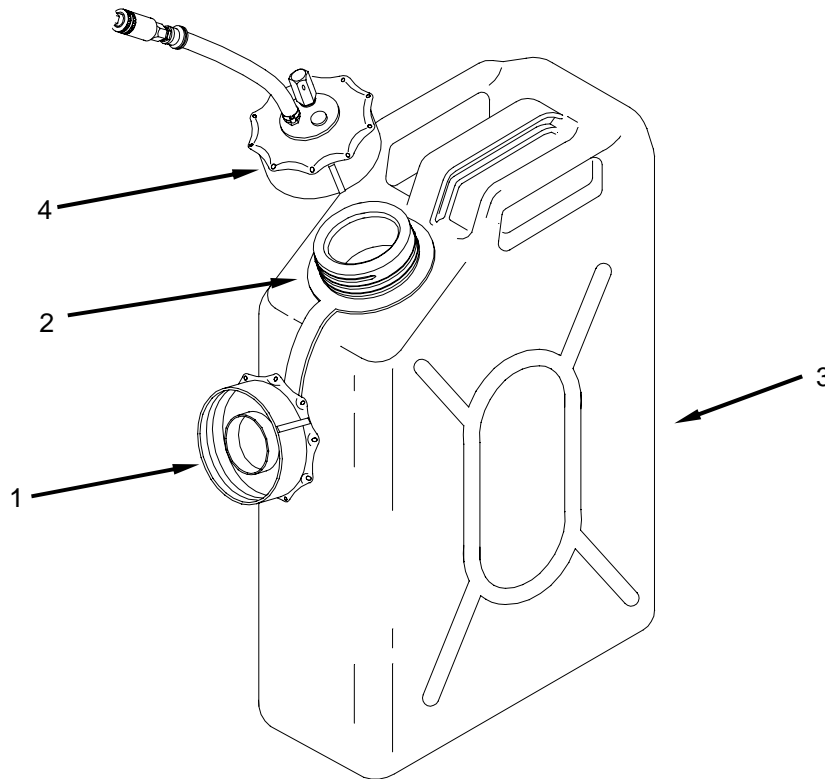

Figure 10. Install Fuel Can Adapter.

NOTE

Ensure the Y adapter valves are in the OFF position before installing the Y adapter (**Figure 11, Item 1**), as shown in Figure 11.

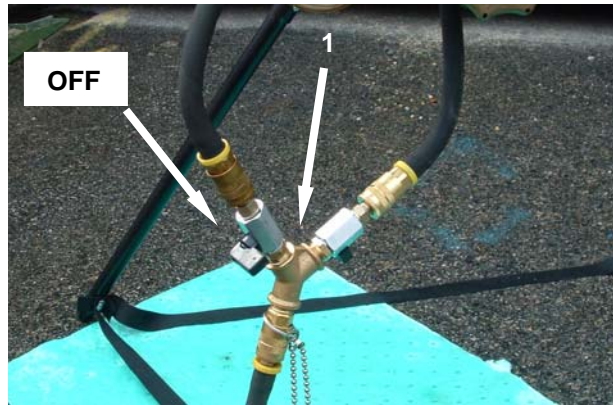

Figure 11. Y Adapter Valves in OFF Position.

3. Set the assembled fuel cans adjacent to the fuel can stand, and attach the Y adapter (**Figure 12, Item 1**) to the gravity feed adapter fittings (**Figure 12, Item 2**).
4. Connect the fuel hose (**Figure 12, Item 3**) to the Y adapter (**Figure 12, Item 1**).

**WARNING**

Excessive weight hazard – a full fuel can weighs approximately 35 pounds (15.0 kg). Soldiers must lift the fuel can with their legs, not their back, to prevent injury. Failure to do so may result in serious back, muscular, or skeletal injuries.

NOTE

Make sure that the gravity feed adapter connection is fully seated and secured to avoid leaking.

5. Invert one fuel can (**Figure 12, Item 4**) with installed fuel can adapter (**Figure 12, Item 5**) and attached Y adapter, and mount on the assembled fuel can stand (**Figure 12, Item 6**) so that the gravity feed adapter faces the ground.
6. Slide the handle of the fuel can (**Figure 12, Item 4**) onto the right support arm (**Figure 12, Item 7**).
7. Repeat steps 5 and 6 for the second fuel can.
8. Feed the right support strap (**Figure 12, Item 8**) through the fuel can handle, up across the front of the fuel can body.
9. Wrap the left support strap (**Figure 12, Item 9**) over the bottom of the fuel cans (**Figure 12, Item 4**), and secure to the right support strap (**Figure 12, Item 8**). The strap helps secure a partially filled fuel can to the fuel stand during windy conditions.

10. If any fuel leaks occur, refer to WP 0032 00, "Leakage definition for performing PMCS".



Figure 12. Install Fuel Cans on Stand.

CONNECT FUEL HOSE TO HEATER**WARNING**

Gasoline, JP-4, used motor oil, fuel mixtures, solvents or other unauthorized fuels must **NOT** be used with the SHC-60K under any circumstance. Only JP-8 or an approved alternate fuel as detailed in Table 1 may be used. Failure to observe fuel requirements could cause damage to the heater assembly and injury or death to personnel within or around the tent and the heater assembly. Fuel spills shall be cleaned up in accordance with local requirements.

Fuels are toxic and flammable. Wear eye/face protection, avoid contact with skin and clothing, and do not breathe fuel vapors. If contact with eyes or skin is made, immediately flush with clean water and get medical aid for eyes. If contact with clothing or skin is made, immediately remove contaminated clothing and clean skin with mild soap or cleanser and flush with clean water.

NOTE

The heater should run for about 8 hours on five gallons (18.9 L) of fuel.

1. Before connecting the fuel hose (**Figure 13, Item 1**) to the fuel quick disconnect on the heater (**Figure 13, Item 2**), position a section of petroleum absorbent mat (**Figure 13, Item 3**) under the fuel quick disconnect connector (**Figure 13, Item 2**).
2. Remove the protective dust cap, place it behind the quick disconnect connector (**Figure 13, Item 2**), and attach the quick disconnect connector on the end of the fuel hose (**Figure 13, Item 1**) coming from the Y - adapter (**Figure 13, Item 4**) to the fuel quick disconnect (**Figure 13, Item 2**) on the heater assembly. Make sure the hose lies flat and is not kinked or looped.
3. Open the valves on the Y adapter (**Figure 13, Item 4**).
4. Inspect for leaks.

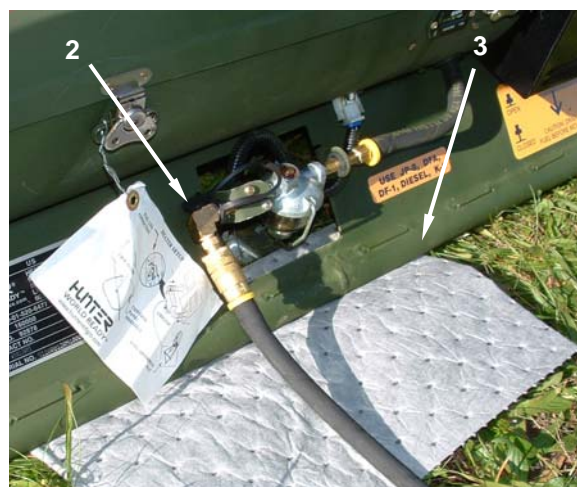

Figure 13. Connect Fuel Hose to Heater.

HEATER SETUP

Connect In-Tent Controller Assembly to In-Tent Controller Cable



WARNING

Ensure that the ON/OFF switch on the in-tent controller is in the OFF position before connecting the controller to the cable in order to prevent accidental start.

1. Make sure the in-tent controller assembly connector (**Figure 14, Item 1**) and the in-tent controller assembly cable connectors (**Figure 14, Item 2**) are clean and are not damaged.
2. Connect the cable connector (**Figure 14, Item 2**) to the in-tent controller assembly (**Figure 14, Item 1**). Remember that the two connectors are “keyed” together and will only fit together one way. Tighten connector securely.

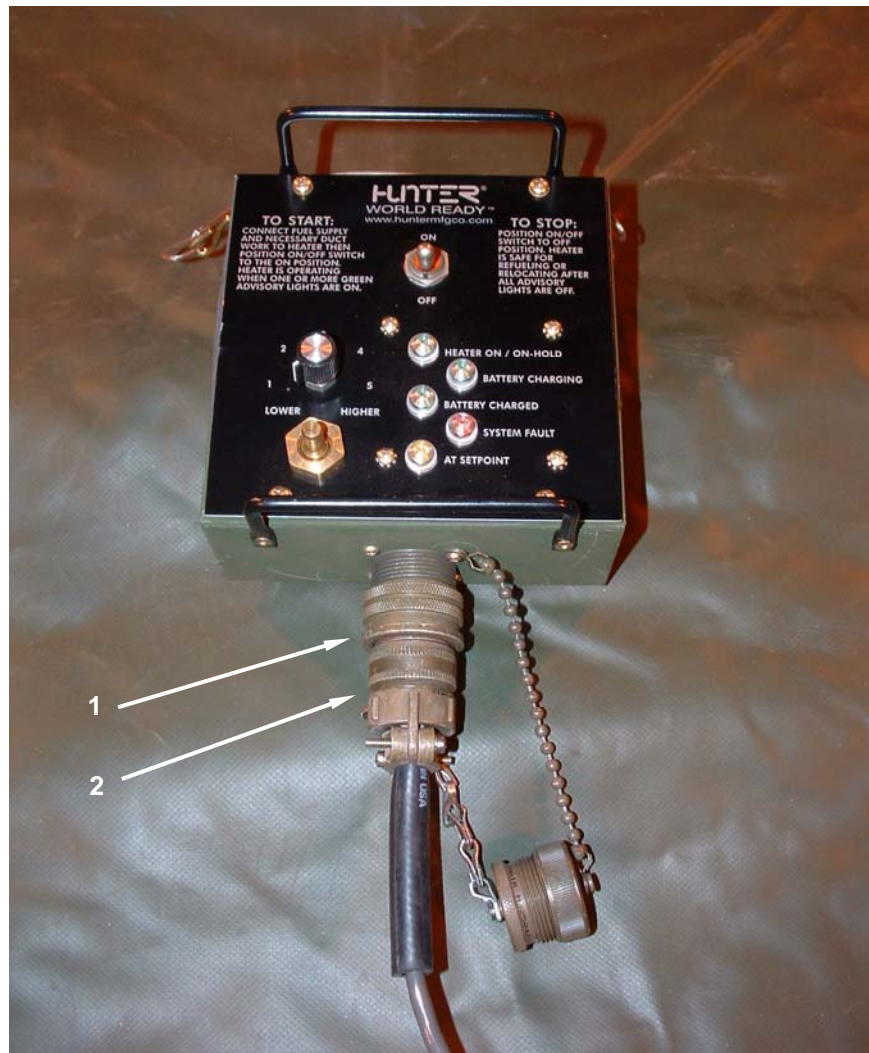

Figure 14. Connect In-Tent Controller Assembly.

Routing the In-tent Controller and Cable Through the Tent Duct Tunnel

NOTE

Ensure that the ON/OFF switch on the in-tent controller assembly is in the OFF position before connecting the in-tent controller cable to the heater. If the switch is in the ON position, the heater will start as soon as the cable is connected to the heater.

The in-tent controller with attached cable (**Figure 15, Item 1**) is routed through the tent duct tunnel (**Figure 15, Item 2**) nearest the breathable air inlet end (**Figure 16, Item 1**) of the heater from outside the tent. The breathable air inlet is the end of the heater opposite the exhaust (**Figure 16, Item 2**) and is labeled on the top of the heater.

To route the in-tent controller and cable (**Figure 15, Item 1**) into the tent, open the end of the tent duct tunnel (**Figure 16, Item 3**) nearest the breathable air inlet (**Figure 16, Item 1**) of the heater and reach into the tent duct tunnel (**Figure 16, Item 3**) placing the in-tent controller with attached cable (**Figure 15, Item 1**) into the interior of the tent. Be sure that the cable is not crimped, tangled, or positioned in a way that could cause the cable to become damaged during heater operation.

Once the in-tent controller is positioned inside the tent, attach the connector (**Figure 16, Item 4**) at the opposite end of the in-tent controller cable to the electrical connector (**Figure 16, Item 5**) on the heater assembly. Tighten the connector securely.



Figure 15. Route the In-tent Controller and Cable Through the Tent Duct Tunnel.

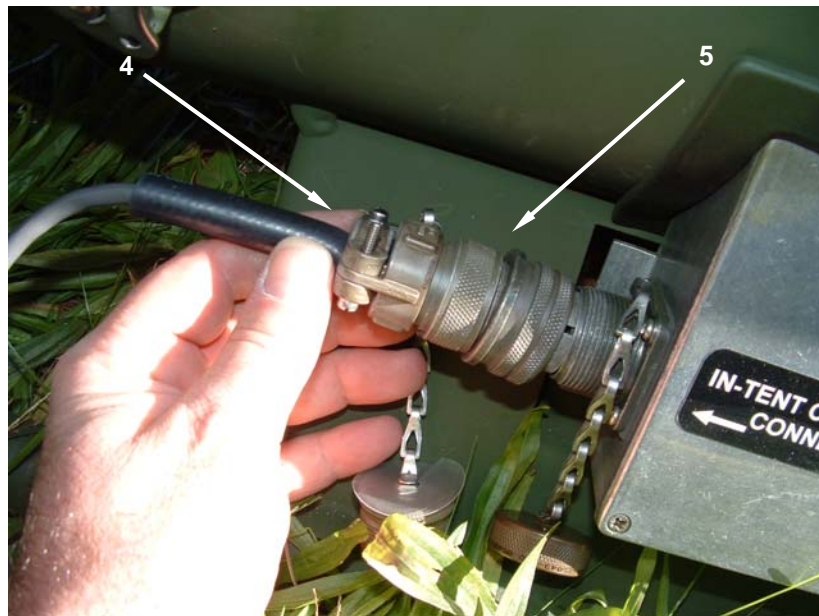

Figure 16. In-Tent Controller and Cable Routed Through the Tent Duct Tunnel.

Positioning the In-tent Controller Inside the Tent

1. Once inside the tent, locate a suitable place within the tent to hang the in-tent controller assembly (**Figure 17, Item 1**). A suitable location would be as far away from the outlet duct as possible and not directly in line with either of the heater duct openings (**Figure 17, Item 2**). The in-tent controller should also be placed at eye level if possible for ease of use and for accurate temperature recognition.
2. Hang the in-tent control assembly from a horizontal tent member or clip (**Figure 17, Item 3**).



Figure 17. Positioning the In-tent Controller Inside the Tent.

INSTALLING THE AIR SUPPLY AND RETURN DUCTS

General

Two air ducts (**Figure 18, Item 1**), 6 feet in length and 12 inches in diameter, connect to the inlet and outlet ends of the heater and move air from the interior of the tent through the heater and back to the interior of the tent.

The two ducts (**Figure 18, Item 1**) are identical as supplied. Either can be used for air supply or return, as long as correct placement of the debris grills is observed and the airflow direction is maintained according to the tags (**Figure 18, Item 2**) installed on the duct.



Figure 18. Air Supply and Return Ducts.

Installing Debris Grills in Air Supply and Return Ducts



WARNING

Debris grills are supplied for both the supply and return ducts to prevent the accidental admission of loose debris into the ducts, and possibly into the heater as well. Do not attempt to operate the heater without the debris grills installed. Flammable debris such as loose paper or leaves may be drawn into the heater, possibly damaging the heater or causing a fire. Failure to observe this precaution may result in serious injury or death to personnel.

NOTE

Observe the airflow pattern as indicated by the arrow tags placed on the ducts. The debris grills will be installed on the “tent end” of each duct.

When the heater is shipped initially, the debris grills (**Figure 19, Item 1**) are not installed in the end of the ducts (**Figure 19, Item 2**) but must be installed before the heater can be used.

1. To install a debris grill (**Figure 19, Item 1**), insert the grill (with the grill side facing out) into the end of one of the ducts (**Figure 19, Item 2**). Secure the debris grill in the end of the duct with the strap (**Figure 19, Item 3**) at the end of the duct by installing the strap into the groove on the debris grill and tighten by pulling the strap.
2. Repeat for the remaining debris grill.

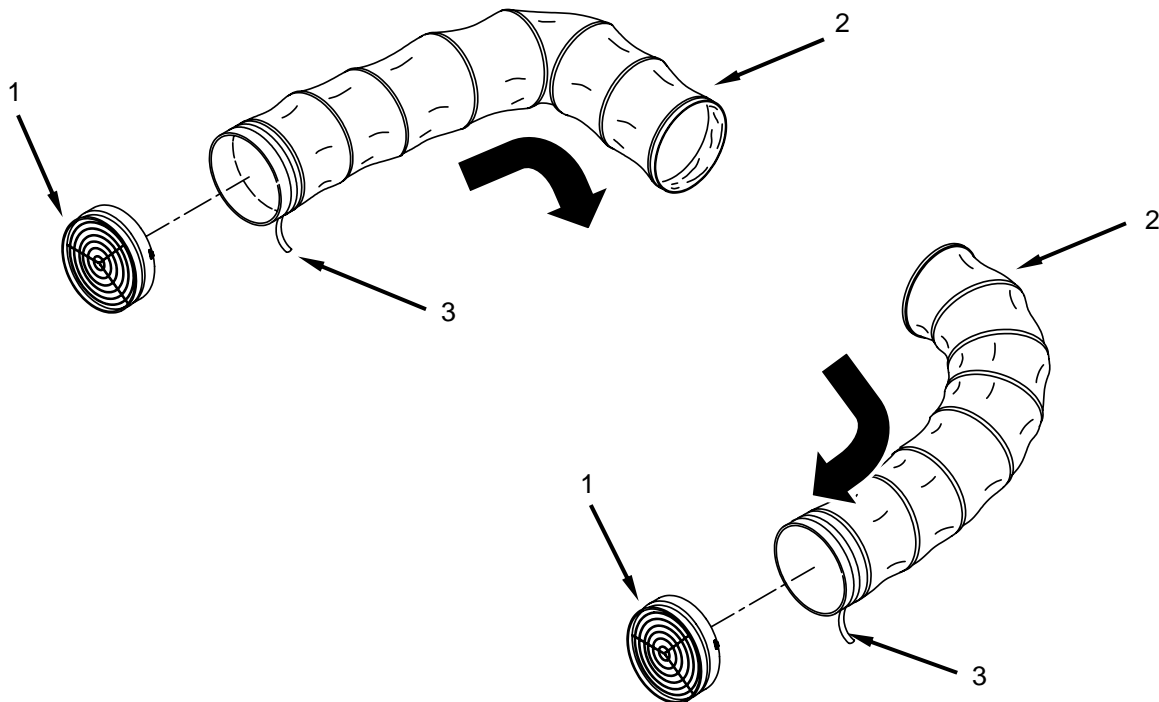

Figure 19. Installing Debris Grills in Air Supply and Return Ducts.

Installing the Air Supply and Return Ducts

1. Remove dust covers (**Figure 20, Item 1**) from heater assembly duct adapters (**Figure 20, Item 2**). Make sure that each of the duct adapter assemblies are securely attached to the heater housing assembly by two catch fasteners (**Figure 20, Item 3**). The fasteners must be tightened securely and in the locked position in the grooves located on the heater housing assembly.
2. Observe the airflow direction arrows on the air ducts (**Figure 20, Items 4 and 5**).
3. Observe the airflow direction labels on the heater housing (**Figure 20, Item 6**).
4. Connect air ducts to heater by matching airflow direction arrows on ducts to airflow labels on the heater housing. The air supply duct arrow (**Figure 20, Item 5**) points toward the heater air intake. The heated air return duct arrow (**Figure 20, Item 4**) points toward the tent. Tighten the duct fastening straps (**Figure 20, Item 7**) snugly to secure the ducts to the heater duct adapters (**Figure 20, Item 2**).



WARNING

During heater operation, air leaving the heated air outlet of the heater and passing through the heated air inlet duct (with debris grill) may exceed 220°F (104°C). Make sure tent personnel are aware of burn hazards and equipment hazards presented by the heated air and the debris grill.

NOTE

Ensure debris grills are inserted in the ends of the ducts. Ensure inside and outside of ducts and the debris grills are free of damage, dirt, and obstructions prior to attachment to the heater assembly.

NOTE

Observe the airflow pattern as indicated by the arrow tags placed on the ducts. The debris grills will be installed on the “open end” of each duct.

5. Install debris grills (**Figure 19, Item 1**) (with the grill side facing out) into the end of one of the ducts (**Figure 20, Item 7**). Secure the debris grills in the end of the duct with the strap (**Figure 19, Item 3**) by placing the strap into the groove on the debris grill. Tighten by pulling the strap.
6. Insert the end of the heated air return duct (**Figure 20, Item 4**) and air supply duct (**Figure 20, Item 5**) into the tent duct tunnels (**Figure 20, Item 8**)
7. Secure the tent duct tunnel ties (**Figure 20, Item 9**). Do not secure the straps so tightly that the air flow within the duct is restricted.



Figure 20. Installing the Air Supply and Return Ducts.

FINAL CHECKS BEFORE OPERATION**WARNING**

Gasoline, JP-4, used motor oil, fuel mixtures, solvents or other unauthorized fuels must NOT be used with the SHC-60K under any circumstance. Only JP-8 or an approved alternate fuel as detailed in Table 1 may be used. Use of unapproved fuels can create a potential fire and explosion hazard. Failure to observe fuel requirements could damage to the heater assembly and injury or death to personnel within or around the tent and the heater assembly. Fuel spills shall be cleaned up in accordance with local requirements.

CAUTION

Kinks in the fuel hose can damage the hose, and will restrict or stop fuel flow to the heater. Loops in the hose may allow air to become trapped, resulting in diminished fuel flow.

1. Make sure that the fuel hose leading from the fuel can to the heater is not kinked or looped and lies flat on the ground. Make sure all fuel connections are correct, secure, and do not leak at the gravity feed adapter or fuel quick disconnect connector at the heater. Ensure all ducts are clean and free of dirt and obstructions prior to starting the heater.
2. Ensure that the battery pack connector (**Figure 21, Item 1**) is connected to the lower housing assembly battery connector (**Figure 21, Item 2**).

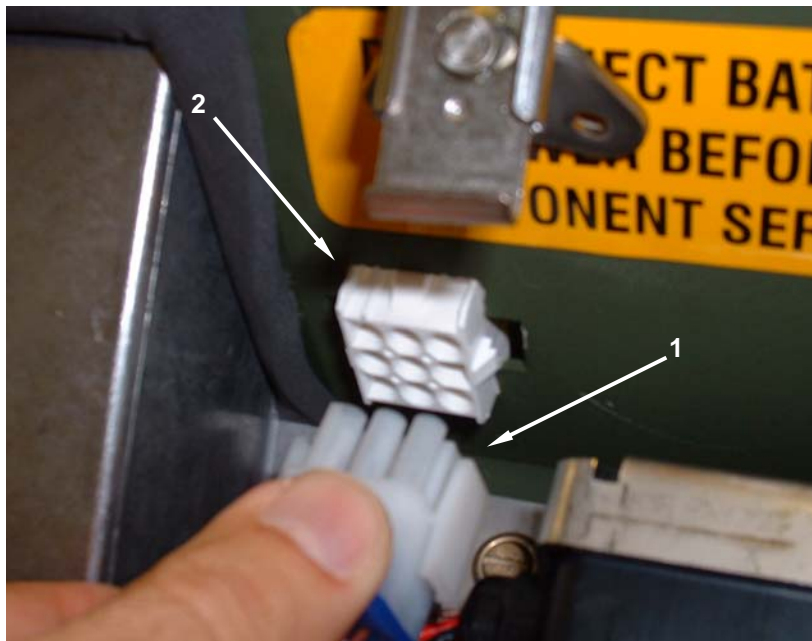

Figure 21. Connect the Battery Pack.

The heater assembly is now ready for operation.

END OF WORK PACKAGE

**OPERATOR'S AND UNIT MAINTENANCE MANUAL
SPACE HEATER, CONVECTIVE 60K BTU (SHC-60K)
NSN 4520-01-520-6477
OPERATING UNDER USUAL CONDITIONS**

OPERATING THE SPACE HEATER, CONVECTIVE 60K BTU (SHC-60K)

This work package has information and instructions for startup, operating, refueling, shutdown, and emergency shutdown of the heater.

Preparation for Starting

Before operating the heater, you must be familiar with the heater controls. Refer to WP 0004 00 entitled "Description and Use Of Operator Controls And Indicators", to review the functions of controls and indicators before operating the heater.

This heater is designed to operate with minimal operator intervention. Once the heater has been put into operation, the only action required of the operator is adjusting the LOWER-HIGHER knob (**Figure 1, Item 1**) (thermostat) on the in-tent controller assembly (**Figure 1, Item 2**) if the temperature in the tent becomes too hot or too cold.

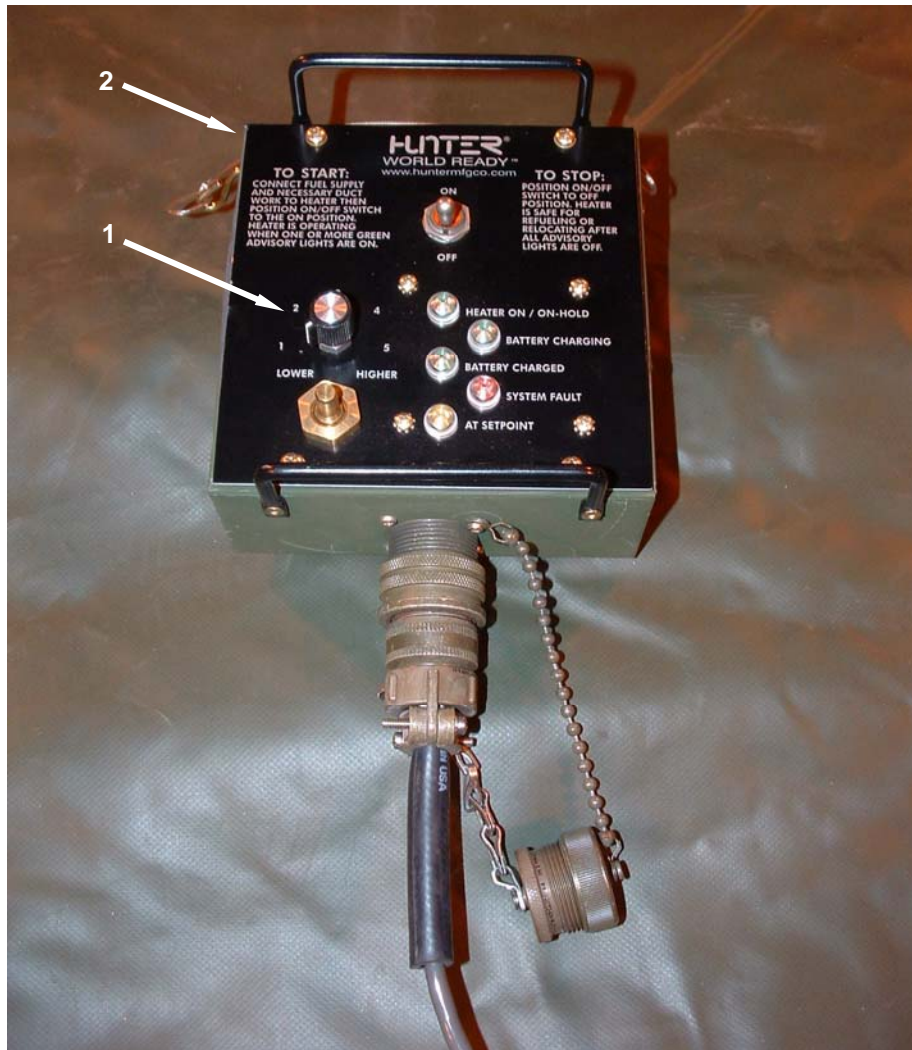

Figure 1. In-tent Controller Assembly.

**WARNING**

Small, portable, shelter heaters of this type are not designed to be moved during operation or before purge cycles are complete. Serious injury, skin burns, or death can occur if the heater assembly is moved while operating or before the HEATER ON/ON-HOLD advisory light goes OFF and the blower fans stop, indicating the end of operation, post purge, and cool-down cycle completion.

During operation, some metal components of the heater assembly, such as the debris grill on the outlet duct, the upper and lower heater housing assemblies, combustion exhaust pipe (near heat exchanger), etc., become very hot, and can cause severe burn injuries if contact with bare skin occurs. Combustible material must be kept at least 2 feet away from the sides of the heater during operation.

Carbon monoxide is a gas without color, smell, or taste, but can kill you. Breathing carbon monoxide may produce symptoms of headache, dizziness, loss of muscular control, a sleepy feeling, and unconsciousness or coma. Brain damage or death can result from heavy exposure. Carbon monoxide is present in the exhaust fumes of any fuel-burning heaters and internal combustion engines. Fatal concentrations of carbon monoxide will occur if the Space Heater, Convective 60K BTU (SHC-60K), or any fuel burning space heater, is operated in an enclosed area such as a tent or structure.

Make sure the heater assembly has been properly set up and the appropriate fuel selected as detailed in Table 1 of WP 0005 00.

Make sure the fuel can is full before starting. If the fuel can is empty, refer to the section of this work package entitled "Refueling the Convective Space Heater".

Starting the Heater

To start the heater, switch the ON/OFF switch (**Figure 2, Item 1**) on the in-tent controller (**Figure 2, Item 2**) to the ON position. The green HEATER ON/ON-HOLD advisory light (**Figure 2, Item 3**) will illuminate and the Power-On Self Test (POST) will begin.

**WARNING**

During heater operation, air leaving the HEATED AIR OUTLET of the heater and passing through outlet duct with louver may exceed 220°F. Make sure tent personnel are aware of burn hazards and equipment hazards presented by the heated air and the louver.

CAUTION

If the heater does not start after three start attempts, go to WP 0008 00 for troubleshooting procedures. An excessive number of start attempts without a recharge cycle may drain the battery.

NOTE

The heater assembly can be shut down in a normal manner at any time by placing the ON/OFF switch to the OFF position. However, to insure both a fully charged battery for subsequent operation and a longer battery life, the heater assembly, whenever possible, should be allowed to run until the green BATTERY CHARGED light (**Figure 2, Item 4**) illuminates.

When first setting the LOWER-HIGHER control knob (**Figure 2, Item 5**), on the in-tent controller assembly (**Figure 2, Item 2**), it should be set it to its highest setting. When the tent has reached a comfortable temperature, turn the LOWER-HIGHER knob down until the amber AT SETPOINT light (**Figure 2, Item 6**) illuminates. The heater control assembly will then regulate to this temperature.

The heater will run at full power until the BATTERY CHARGING light comes on. If the red SYSTEM FAULT light (**Figure 2, Item 7**) illuminates, the heater will enter shut down mode and the SYSTEM FAULT light will flash from 1 to 18 times and an audible series of tones indicating a diagnostic code. These diagnostic codes provide the user with information regarding the nature of the fault. In some cases the problem may be corrected by the operator and a re-start may be attempted. If the problem is of a more serious nature and cannot be corrected by the operator, the heater should be referred to Unit Maintenance for repair. Refer to WP 0008 00 entitled "Troubleshooting Index" to reference the various diagnostic codes.

NOTE

The heater will operate at full power until the BATTERY CHARGING light illuminates. Once the light comes on, the LOWER-HIGHER control can be used to regulate heater output.

Once the ON/OFF switch (**Figure 2, Item 1**) on the in-tent controller assembly (**Figure 2, Item 2**) has been placed in the ON position, the HEATER ON/ON-HOLD advisory light (**Figure 2, Item 3**) is lit and the heater is in one of the following modes:

Power-On Self Test (POST)

During the Power-On Self Test (POST), the heater runs an internal diagnostic to ensure the heater is safe and in operable condition.

Normal Operation

The combustion air blower assembly and the heated air blower assembly fan continue to operate during normal operation to circulate the heated breathable air to the tent and to exhaust combustion fumes.

On-hold

In the HEATER ON/ON-HOLD mode, the heater does not heat but automatically begins heating in response to either changes in the tent temperature or changes to the LOWER/HIGHER setting on the in-tent controller assembly.

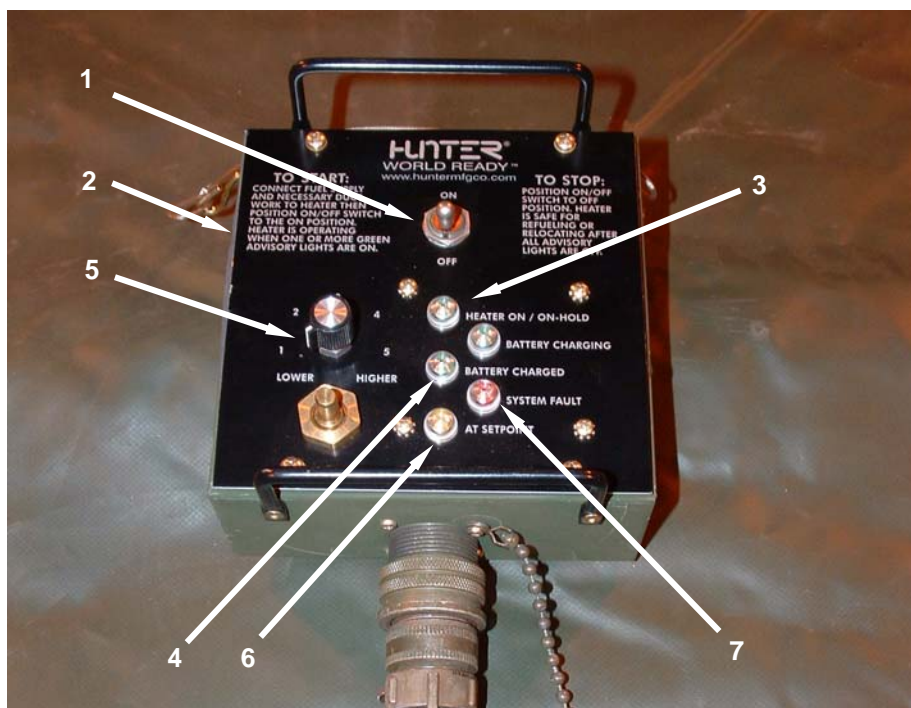

Figure 2. Starting Heater with In-Tent Controller.

A summary of the starting procedure, along with indications of normal operation, is provided in Table 1.

Table 1. Typical Starting Procedure Timetable.

Function	Approximate Elapsed Time From Actuation of ON Switch	Indications
Switch ON	0 seconds	
Power on self-test	6 seconds	Continuous beep from control box with all lights on. All fans come on momentarily.
Glow plug heating	14 seconds	Glow plug comes on and starts heating (no visible or audible indications).
Fuel pump on	30 seconds	Recognized by audible slow clicking of the fuel pump.
Vent fan on	45 seconds	Vent fan begins moving air through heater.
Combustion Air Blower on	1 minute 8 seconds	Combustion starts. May see a puff of white exhaust. Fuel pump audible clicking rate increases.
Battery Charging light on	8 to 10 minutes	The battery begins charging.
Battery Charged light on	40 to 60 minutes	Battery fully charged. May take up to 2 hours depending on charge level of battery before start.

STOPPING THE HEATER

When the ON/OFF switch (**Figure 3, Item 1**) is placed in the OFF position, the green HEATER ON/ON-HOLD advisory light (**Figure 3, Item 2**) will go out and the fuel supply is shut off via the fuel solenoid valve; however, the combustion blower assembly and heated air blower fan continue to operate as the heater control assembly goes to the post-purge mode. The fans can be heard as they continue to run during the post-purge cycle.



WARNING

Small, portable, shelter heaters of this type are not designed to be moved during operation or before purge cycles are complete. Serious injury, skin burns, or death can occur if the heater assembly is moved while operating or before the HEATER ON/ON-HOLD advisory light goes OFF and the blower fans stop, indicating the end of operation, post purge, and cool-down cycle completion.

During operation, some metal components of the heater assembly, such as the debris grill on the outlet duct, the upper and lower heater housing assemblies, combustion exhaust pipe (near heat exchanger), etc., become very hot, and can cause severe burn injuries if contact with bare skin occurs.

Do not attempt service procedures on a burner that has recently been in operation. Let the burner cool for at least 30 minutes before performing any service procedures, in order to avoid the possibility of serious burns.

Complete heater shutdown is indicated by the stopping of the combustion blower assembly and heated air blower fan. The remaining advisory lights will extinguish as each heater sequence that the respective lights monitor ceases operation.

Refer to Table 2 for an approximate timetable of post-purge events and indications.

Table 2. Typical Post-purge Procedure Timetable.

Function	Approximate Elapsed Time from Actuation of OFF Switch	Indications
Actuate OFF switch	0 seconds	Fuel pump audible clicking stops.
Exhaust vapors	2 minutes 40 seconds	May see puff of vapors from exhaust.
Post-purge complete	4 minutes	Vent fan and combustion fan stop.

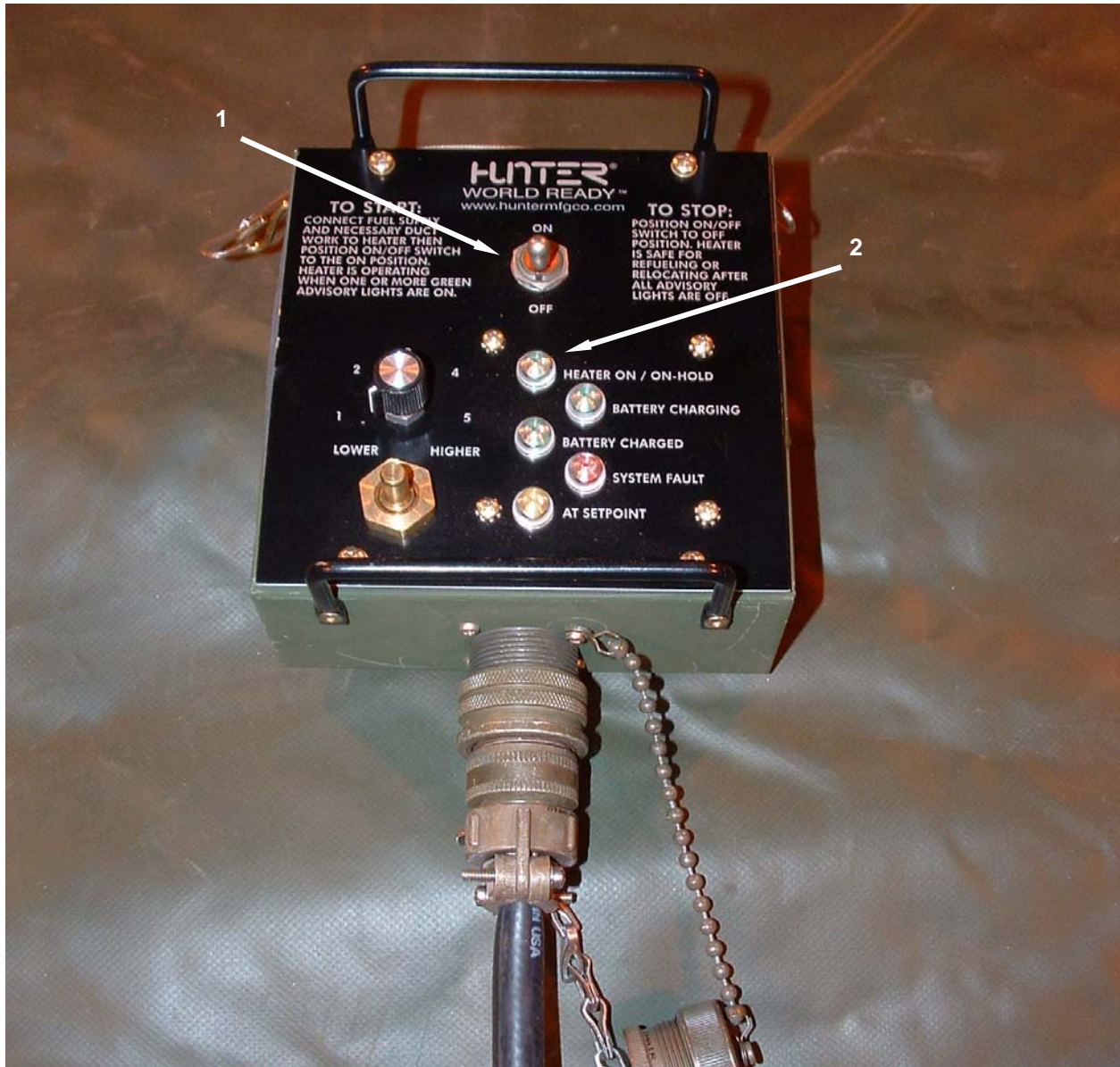

Figure 3. Stopping Heater with In-Tent Controller.

REFUELING

**WARNING**

Fuels are toxic and flammable. Do not refuel near open flame or other ignition sources. Only refuel in a well-ventilated area. Wear eye/face protection, avoiding contact with skin and clothes, and don't breathe vapors. If contact with eyes or skin is made, immediately flush with clean water and get medical aid for eyes. If contact with clothing or skin is made, immediately remove contaminated clothing and clean skin with mild soap or cleanser and flush with clean water.

Always store fuel cans in well-ventilated areas as far away from open flames and other potential ignition sources as possible. Leaking or spilled fuels will create a fire danger-injuries/death and environmental damage. Fuel spills must be cleaned up in accordance with local requirements.

JP-8 is the preferred fuel for use in the SHC-60K for all ambient temperatures. If JP-8 is not available, only those fuels identified in Table 3 rated for the outside temperature where the heater will be operating should be used. Use of unapproved fuels creates a fire and explosion hazard. Failure to observe fuel requirements could cause damage to the heater and injury or death to personnel within or around the tent and the heater.

Always switch heater control to the OFF position and wait until the blower fans stop and all advisory lights go out before beginning a refueling operation.

CAUTION

Always keep fuel hoses and fuel cans clean and free of dust, dirt, and water. Make sure fuel hoses lie flat without kinks or loops that could trap air in the lines and slow the fuel flow to the heater.

NOTE

The heater should run for about 8 hours on five gallons (18.9 L) of fuel.

1. Place the ON/OFF switch (**Figure 4, Item 1**) of the in-tent controller assembly (**Figure 4, Item 2**) in the OFF position or verify that it is in the OFF position.
2. If the heater assembly has been operating, allow it to complete the post-purge mode and make certain that all advisory lights (**Figure 4, Item 3**) are off.



Figure 4. Stopping Heater with In-Tent Controller For Refueling.

3. When the blower fans stop at the end of the post-purge mode, unstrap and remove fuel cans (**Figure 5, Item 1**) from fuel can stand (**Figure 5, Item 2**).
4. Loosen and remove the fuel can adapter (**Figure 5, Item 3**) from one can and place it on the absorbent mat (**Figure 5, Item 4**).
5. Make sure all components of the fuel system are clean and free of dirt and damage that could contaminate the fuel supply or cause leakage.



WARNING

Gasoline, JP-4, used motor oil, solvents, fuel mixtures, or other unauthorized fuels must NOT be used with the Space Heater, Convective, 60K BTU (SHC-60K) under any circumstance. Only JP-8, or an approved alternate fuel as detailed in Table 3, may be used. Failure to observe fuel requirements could cause damage to the heater assembly, or fire or potential explosion hazard, with resulting injury or death to personnel within or in proximity to the tent or the heater assembly.

CAUTION

Do not mix fuels. If temperature change or source of supply dictates the need to change fuels, expend the remaining fuel before refueling with a different fuel. Mixing fuels may alter the fuels properties in unpredictable ways, with the potential for heater malfunction or mechanical damage.

6. JP-8 is the preferred fuel for use in the SHC-60K for all ambient temperatures. If JP-8 is not available, fill the fuel can with an approved alternate fuel as listed in Table 3.

Table 3. Fuel Selection.

	Ambient Temperature	Specification	Military Symbol
Primary Fuel	Above -60 °F (-51.1 °C)	MIL-T-83133	*JP-8
Alternate Fuels	Above -60 °F (-51.1 °C)	VV-F-800	DF-A
	Above -60 °F (-51.1 °C)	MIL-P- 25576	K-1
	Above -25 °F (-31.7 °C)	MIL-T-83133	JP-5
	Above -25 °F (-31.7 °C)	VV-F-800	DF-1
	Above +20 °F (-6.7 °C)	VV-F-800	DF-2



WARNING

Excessive weight hazard – a full fuel can weighs approximately 35 pounds (15.0 kg). Soldiers must lift the fuel can with their legs, not their back, to prevent injury. Failure to do so may result in serious back, muscular, or skeletal injuries.

7. Install the fuel can adapter (**Figure 5, Item 3**) onto the fuel can (**Figure 5, Item 1**). Tighten securely.
8. Place fuel can onto fuel can stand assembly (**Figure 5, Item 2**).

NOTE

Use the same fuel in both cans when refueling. If there is insufficient fuel of any given type to fill both cans, expend that fuel before refueling with a different fuel.

9. Repeat Steps 4. through 8. for the remaining fuel can.
10. Strap cans in place on fuel stand in accordance with tag attached to stand assembly or procedures outlined in WP 0005 00 entitled "Assemble the Fuel Can Stand".
11. Make sure fuel connections are tight and that there are no fuel leaks.
12. Make sure fuel hose (**Figure 5, Item 5**) lies flat on the ground and is not looped or kinked.
13. Heater assembly is now ready for operation. Make sure heater setup has not been changed, ducts are properly positioned, and heated air is directed in a safe manner. See applicable setup instructions in WP 0005 00.
14. If heat is desired, place heater ON/OFF switch in the ON position and verify that HEATER ON/ON-HOLD light is lit.



Figure 5. Refueling the SHC-60K BTU.

CHARGING THE BATTERY

Charging the Battery During Normal Operation

1. Place the heater ON/OFF switch (**Figure 6, Item 1**) of the in-tent controller assembly (**Figure 6, Item 2**) in the ON position and verify that green HEATER ON/ON-HOLD light (**Figure 6, Item 3**) is lit. (Refer to troubleshooting if light is not on). At a minimum, allow the heater to run through a complete charging cycle. A charging cycle starts when the heater ON/OFF switch is moved to the ON position and ends when green BATTERY CHARGED light (**Figure 6, Item 4**) comes on.
2. If heat is no longer desired, place the heater ON/OFF switch (**Figure 6, Item 1**) in the OFF position and verify that the blower fans stop after post-purge. Cool down is then complete.

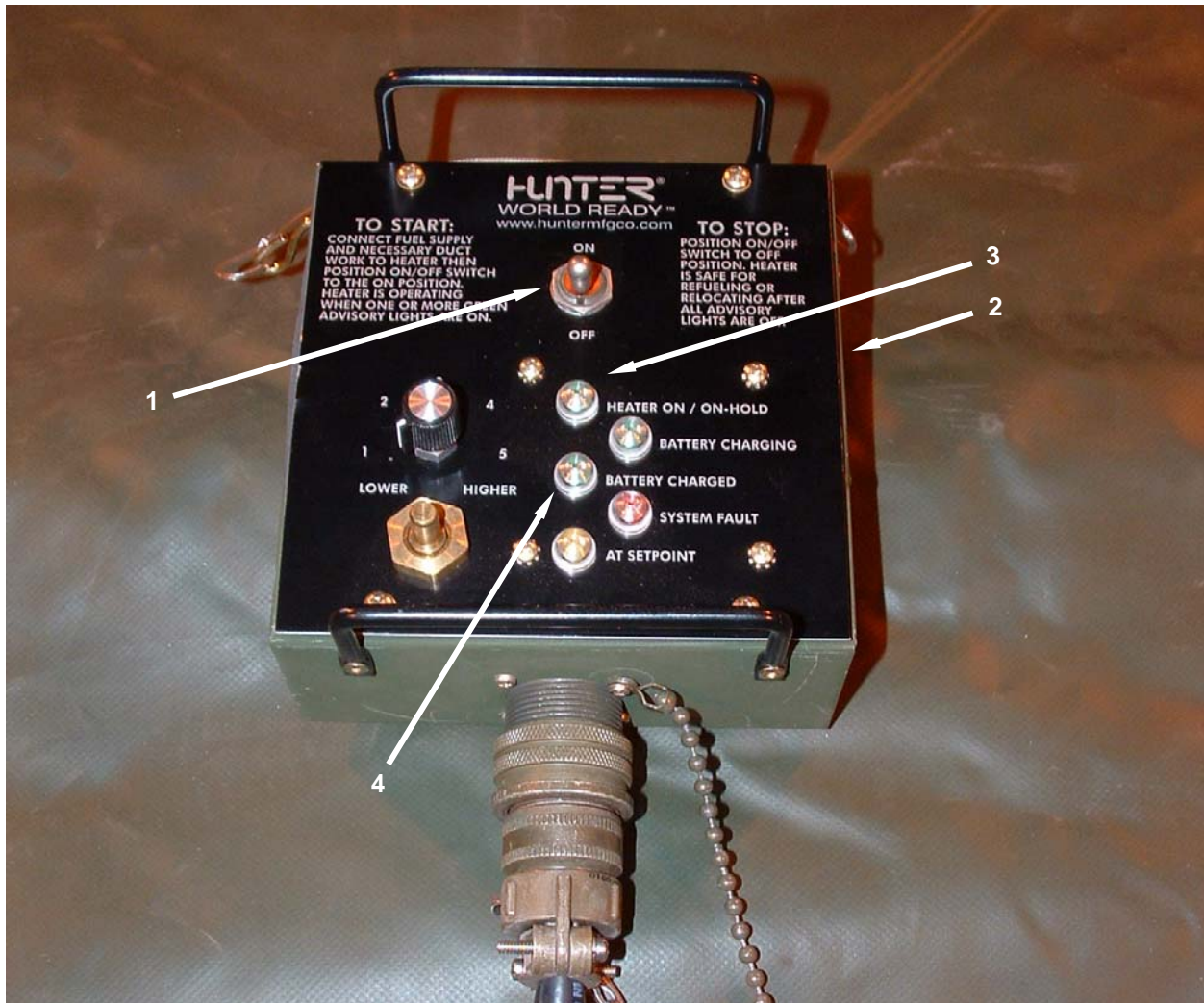

Figure 6. Charging the Battery During Normal Operation.

Charging the Battery Using a NATO Charging System (AAL)

Under normal conditions the SHC-60K is responsible for recharging the on-board battery pack. If necessary, a NATO charging system cable with integral transformer may be used to charge the battery on the SHC-60K (**Figure 7**).



Figure 7. NATO Charger.

NOTE

It may be necessary to remove the battery from the heater in order to use the NATO charging system. If so, notify Unit maintenance.

1. To charge the battery (**Figure 8, Item 1**) using a NATO charging system (**Figure 8, Item 2**), disconnect the battery connector (**Figure 8, Item 3**) from the heater and engage the connector (**Figure 8, Item 4**) on the end of the NATO charging adapter with the connector on the battery pack.
2. Plug the slave connection (**Figure 8, Item 5**) into the matching receptacle on the vehicle or equipment used to provide electrical power.
3. Verify that the charging unit green power light (**Figure 8, Item 6**) is blinking, indicating that the NATO charging system (**Figure 8, Item 2**) is charging.
4. When the charging unit green power light (**Figure 8, Item 6**) stops blinking and stays lit, this indicates that the battery is charged. Depending upon the battery temperature, recharge time for the battery will be approximately 30 minutes. The battery will take longer to recharge in cold weather conditions.
5. Disconnect the NATO charging system (**Figure 8, Item 2**), and reconnect the battery connector to the heater.



Figure 8. Connecting the NATO Charger.

DECALS AND INSTRUCTION PLATES

Table 4 illustrates the decals and information plates affixed to the heater assembly as well as the location of each decal or plate on the heater assembly.

Table 4. SHC-60K Labels and Instruction Plates.





Label or Instruction Plate	Location Code
	Figure 9, Item 1
	Figure 9, Item 2
	Figure 9, Item 3
	Figure 9, Item 4
	Figure 9, Item 5

Table 3. SHC-60K Labels and Instruction Plates - Continued.



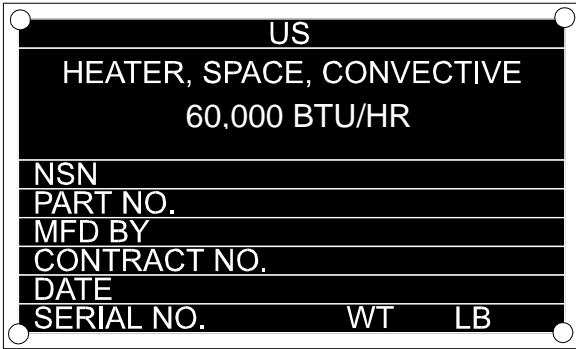

Label or Instruction Plate	Location Code
	<p>Figure 9, Item 6</p>
	<p>Figure 9, Item 7</p>
	<p>Figure 9, Item 8</p>
	<p>Figure 9, Item 9</p>
	<p>Figure 9, Item 10</p>

Table 3. SHC-60K Labels and Instruction Plates - Continued.





Label or Instruction Plate	Location Code
	<p>Figure 9, Item 11</p>
	<p>Figure 9, Item 12</p>
	<p>Figure 9, Item 13</p>
	<p>Figure 9, Item 14</p>
	<p>*Not Shown</p>

Table 3. SHC-60K Labels and Instruction Plates - Continued.

Label or Instruction Plate	Location Code
	<p>Figure 9, Item 15</p>
<p>AUDIBLE DIAGNOSTIC CODES</p> <ol style="list-style-type: none"> 1. LOW BATTERY VOLTAGE 2. COMBUSTION MOTOR 3. NO FLAME 4. BURNER MAINTENANCE 5. GLOW PLUG 6. TEG OVER TEMPERATURE 7. VOLTAGE REGULATOR 8. TIP-OVER 9. FIN TEMP SENSOR 10. TENT OVER TEMPERATURE 11. LOW SYSTEM VOLTAGE 12. INLET AIR OVER TEMPERATURE 13. NOT USED 14. FUEL SOLENOID 15. FUEL PUMP 16. VENT MOTOR 17. AMBIENT TEMP SENSOR 18. BATTERY TEMP SENSOR <p>REFER TO TROUBLESHOOTING PROCEDURE IN MANUAL</p>	<p>*Not Shown</p>

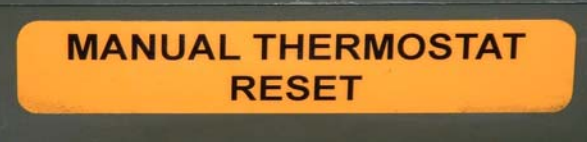
Location of Labels and Instruction Plates

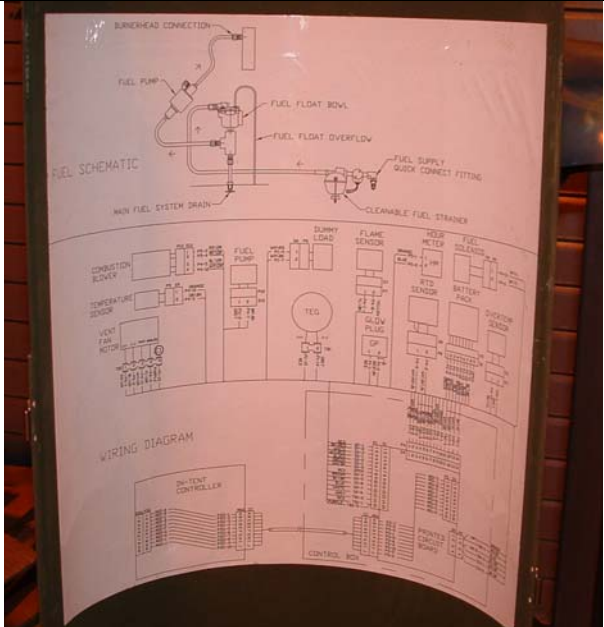
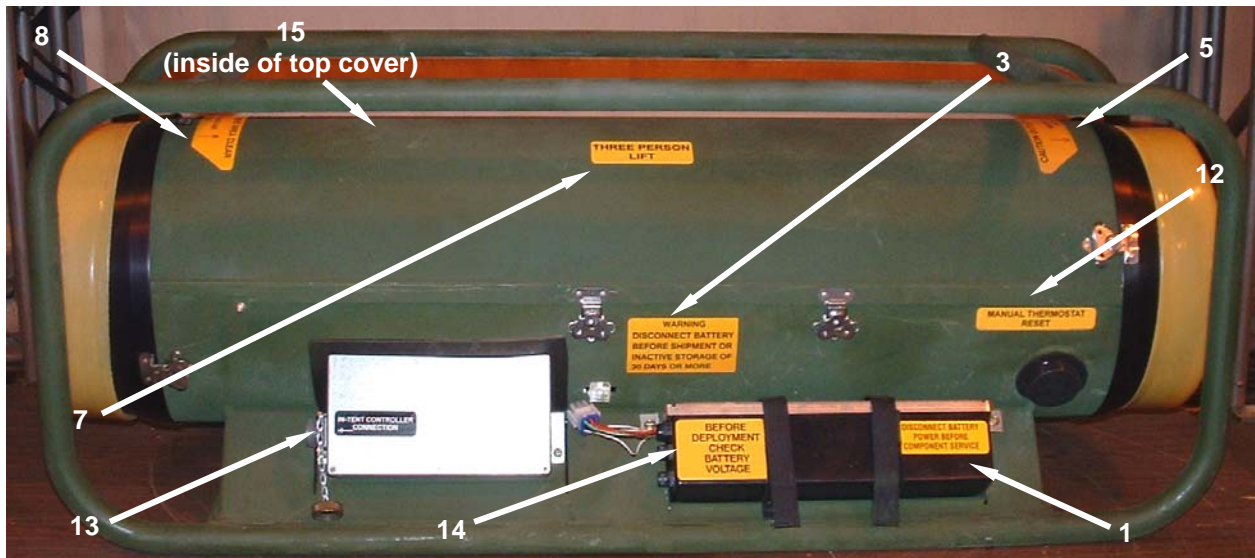
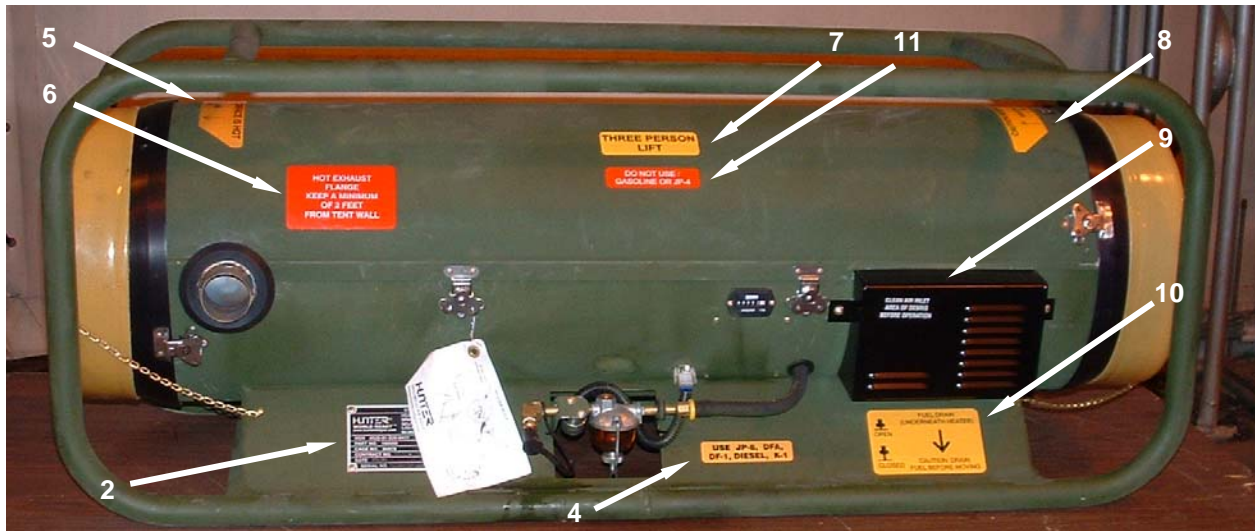

Figure 9. External Label Placement (Labels 1 through 14).

PREPARATION FOR MOVEMENT**WARNING**

Small, portable, shelter heaters of this type are not designed to be moved during operation or before purge cycles are complete. Serious injury, burns, or death can occur if the heater assembly is moved while operating or before the HEATER ON/ON-HOLD advisory light goes OFF indicating the end of operation, post purge, and cool down cycle completion.

**WARNING**

Two people are required to prepare the heater for movement. Failure to attempt this procedure with adequate personnel may result in serious injury to personnel and damage to equipment.

1. Ensure that the heater is off, the blower fans stopped, and all advisory lights off.
2. Disconnect battery at connection (**Figure 10, Item 1**).

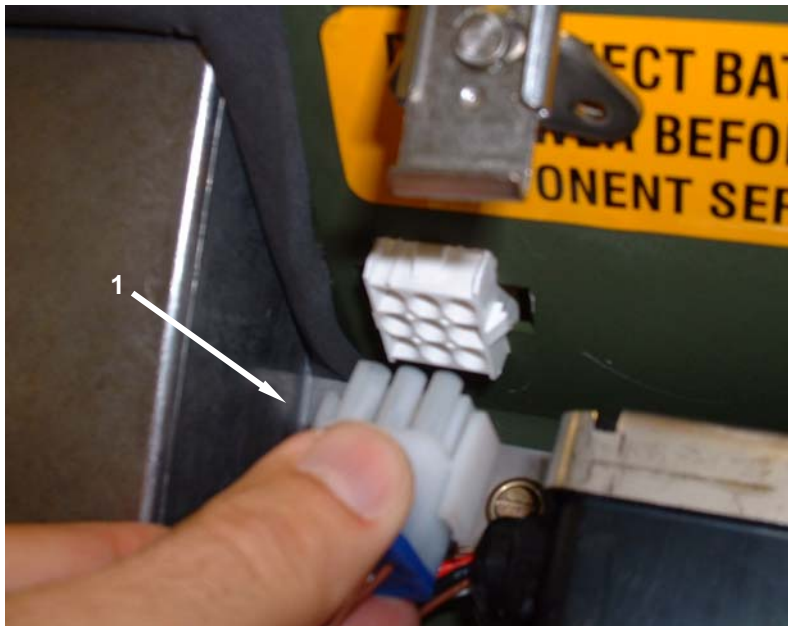

Figure 10. Prepare for Movement – Disconnect Battery.

**WARNING**

Excessive weight hazard – a full fuel can weighs approximately 35 pounds (15.0 kg). Soldiers must lift the fuel can with their legs, not their back, to prevent injury. Failure to do so may result in serious back, muscular, or skeletal injuries.

3. Remove the fuel cans (**Figure 11, Item 1**) from the fuel can stand assembly (**Figure 11, Item 2**). Set the fuel cans down in the upright position.



Figure 11. Prepare for Movement – Remove Fuel Cans.

4. Remove both the air supply and return ducts (**Figure 12, Item 1**) from the heater (**Figure 12, Item 2**) by releasing the straps and sliding the ducts off of the duct adapters (**Figure 12, Item 3**).



Figure 12. Prepare for Movement – Release Ducts.

5. Disconnect the in-tent controller cable (**Figure 13, Item 1**) from the control connector on the heater (**Figure 13, Item 2**) and immediately install the protective dust caps (**Figure 13, Item 3**) on the control connector and the cable connector.

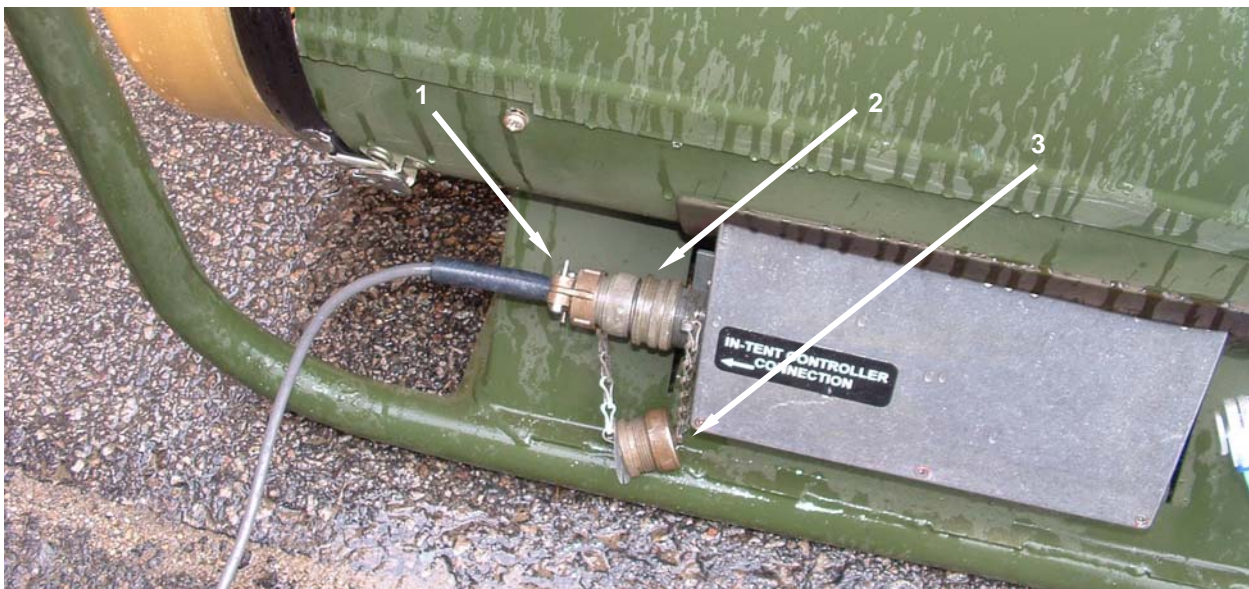

Figure 13. Prepare for Movement – Disconnect the In-tent Controller Cable.

6. Place a mat (**Figure 14, Item 1**) or tray containing petroleum absorbent material under the heater fuel quick disconnect (**Figure 14, Item 2**) to collect the small amount of fuel that may drain from heater (**Figure 14, Item 3**) and the fuel hose (**Figure 14, Item 4**).



WARNING

Fuels are toxic and flammable. Do not refuel near open flame or other ignition sources. Only refuel in a well-ventilated area. Wear eye/face protection, avoiding contact with skin and clothes, and don't breathe vapors. If contact with eyes or skin is made, immediately flush with clean water and get medical aid for eyes. If contact with clothing or skin is made, immediately remove contaminated clothing and clean skin with mild soap or cleanser and flush with clean water.

Always store fuel cans in a well-ventilated area as far away from open flames and other potential ignition sources as possible. Leaking or spilled fuels will create a fire danger-injuries/death and environmental damage. Fuel spills must be cleaned up in accordance with local requirements.



WARNING

Personnel injury/cuts. Leather glove hand protection must be worn. The use of protective gloves will significantly reduce the risk of cut injury. Failure to do so could result in serious injury to fingers or hands.

7. Close the Y adapter (**Figure 14, Item 5**) valves, and disconnect the male end of the fuel hose (**Figure 14, Item 6**) from the Y adapter.

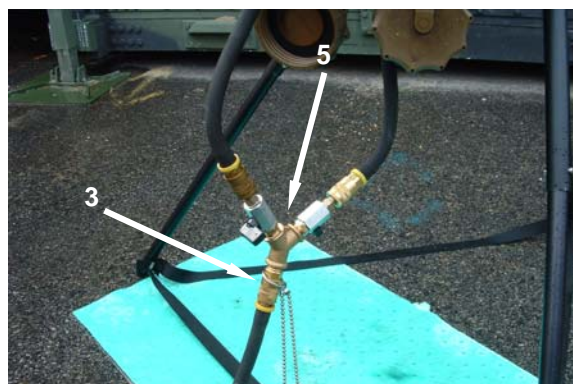
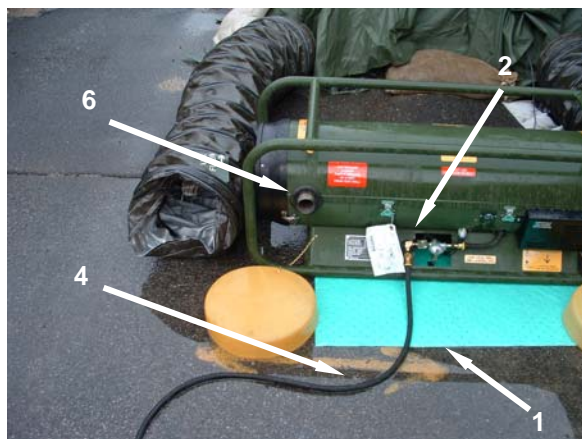

Figure 14. Prepare for Movement – Preparing to Disconnect the Fuel Hose.

8. Remove the Y adapter (**Figure 15, Item 1**) from one fuel can (**Figure 15, Item 2**).
9. Raise the Y adapter (**Figure 15, Item 1**) above the can (**Figure 15, Item 2**), open both valves, and allow the gravity feed adapter (**Figure 15, Item 3**) to drain into the fuel can for 30 seconds.
10. Close both valves on the Y adapter (**Figure 15, Item 1**).
11. Remove the Y adapter (**Figure 15, Item 1**) from the fuel can (**Figure 15, Item 2**), and connect to the remaining fuel can.
12. Raise the Y adapter (**Figure 15, Item 1**) above the can (**Figure 15, Item 2**), open both valves, and allow the gravity feed adapter (**Figure 15, Item 3**) to drain into the fuel can for 30 seconds.
13. Close both valves on the Y adapter (**Figure 15, Item 1**).

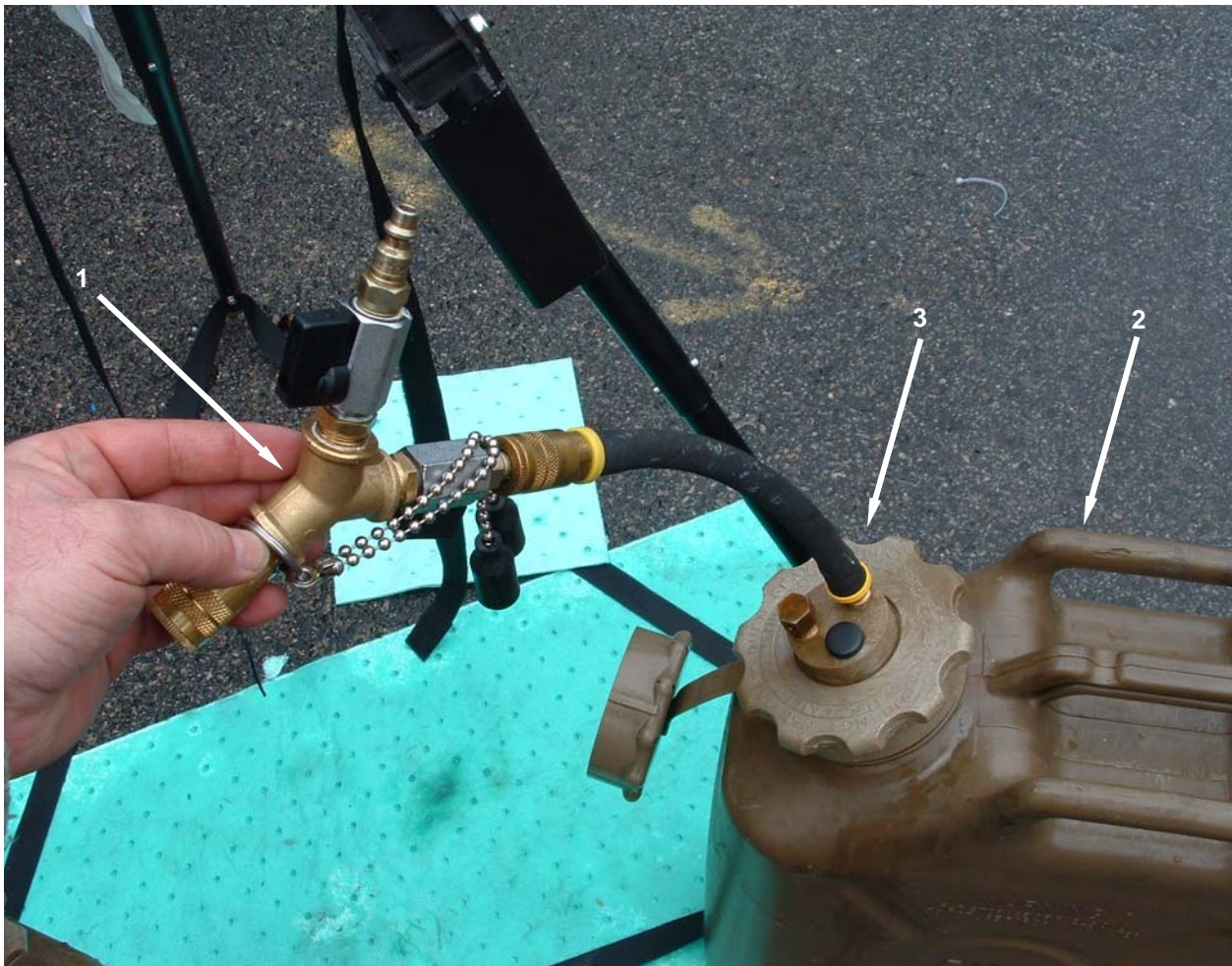

Figure 15. Prepare for Movement – Draining the Y-Adapter and the Gravity Feed Adapters.

14. Remove the gravity feed adapter (**Figure 16, Item 1**) from one fuel can (**Figure 16, Item 2**), and leave the can open.
15. Place the male end of the fuel hose (**Figure 16, Item 3**) into the open can (**Figure 16, Item 2**).
16. Connect the Y adapter (**Figure 16, Item 4**) to the female end of the fuel hose (**Figure 16, Item 3**), and raise the Y adapter above the level of the fuel can (**Figure 16, Item 2**).
17. Open both valves on the Y adapter (**Figure 16, Item 4**), and slowly “walk out” the remaining fuel from the fuel hose (**Figure 16, Item 3**) into the fuel can (**Figure 16, Item 2**) progressively raising the fuel hose from the Y adapter to the fuel can.
18. Close both valves on the Y adapter (**Figure 16, Item 4**), and disconnect the Y adapter from the fuel hose (**Figure 16, Item 3**). Cap the Y adapter male fittings with the attached caps.
19. Remove the male end of the fuel hose (**Figure 16, Item 3**) from the fuel can (**Figure 16, Item 2**), and quickly connect the male and female ends of the fuel hose together. Wipe the connection and hose clean of all fuel, and place the fuel hose on the petroleum absorbent mat (**Figure 16, Item 5**).
20. Install the cap (**Figure 16, Item 6**) on the open fuel can (**Figure 16, Item 2**).
21. Remove gravity feed adapter (**Figure 16, Item 4**) from the remaining fuel can (**Figure 16, Item 4**).
22. Install cap (**Figure 16, Item 6**) on the fuel can (**Figure 16, Item 2**) and tighten securely.
23. Place both gravity feed adapters (**Figure 16, Item 1**) on a petroleum absorbent mat (**Figure 16, Item 5**). Use the mat to wipe any excess fuel from the surface of the gravity feed adapters.

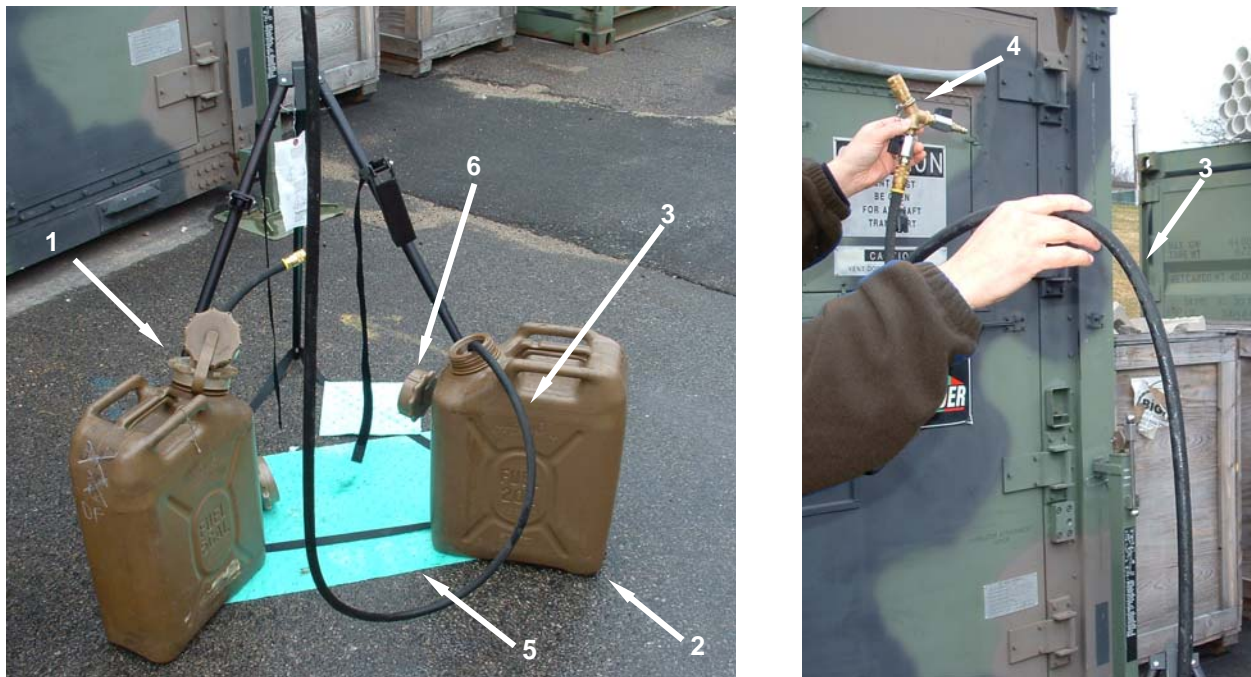

Figure 16. Prepare for Movement – Draining the Fuel Hose.

24. Place a clean container and a petroleum absorbent mat under the heater fuel drain fitting (**Figure 17, Item 1**). Open the fuel drain fitting and allow all fuel to drain from the heater.
25. Open one fuel can and empty the container of drained fuel into the fuel can. Replace the fuel can cap.

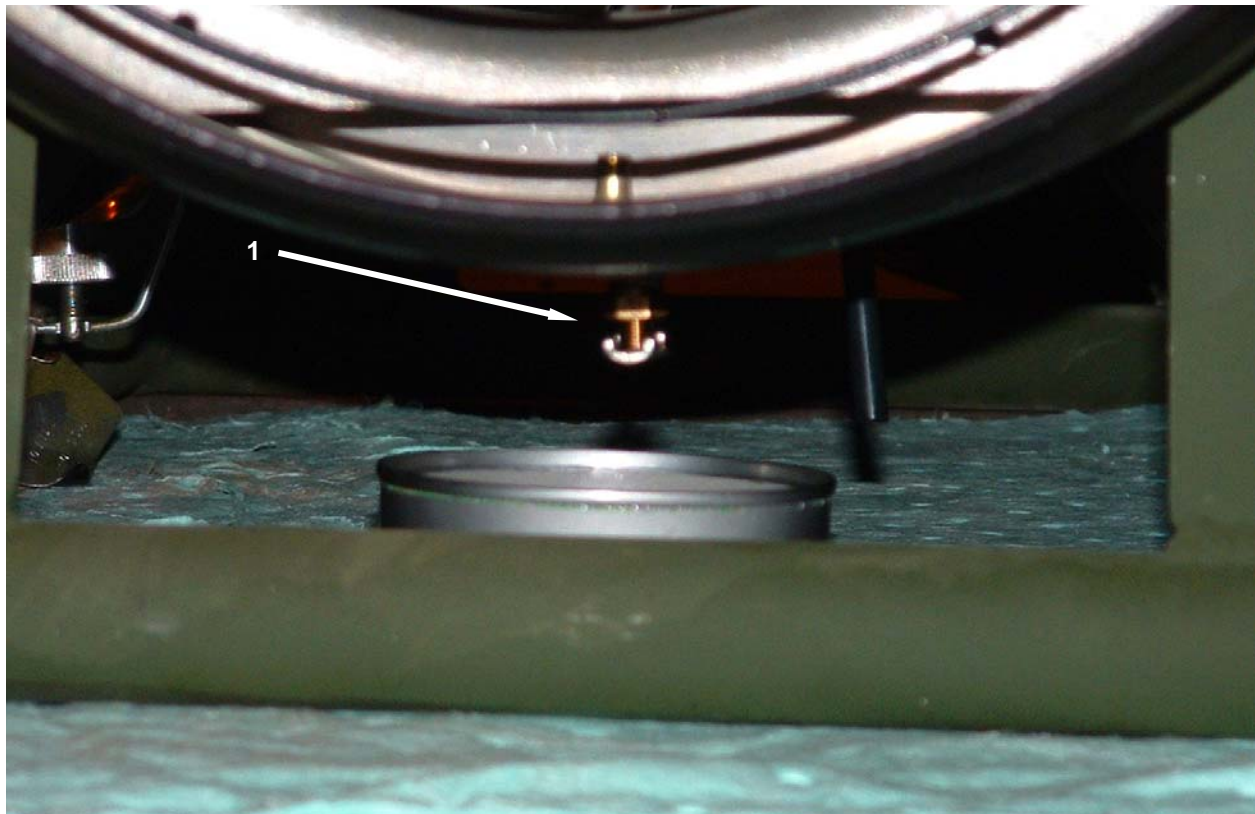
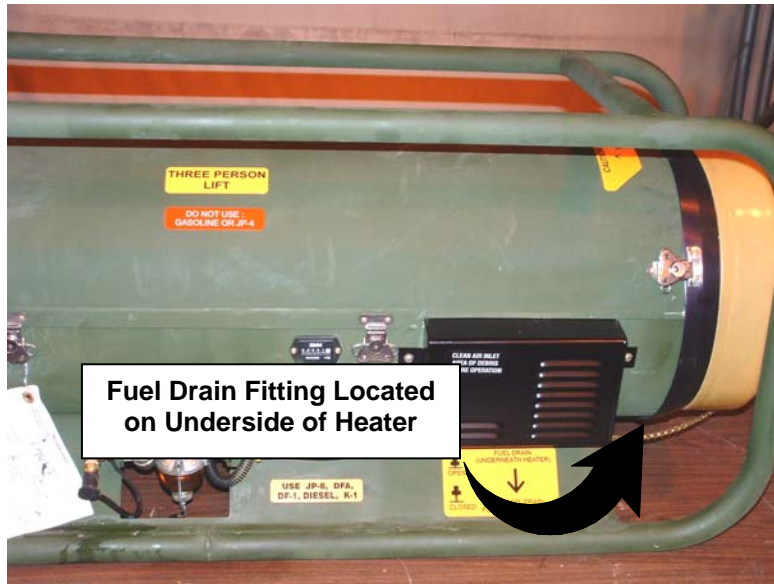

Figure 17. Prepare for Movement – Open Drain Fitting.

26. Place a fuel absorbent mat (**Figure 18, Item 1**) under the sediment strainer (**Figure 18, Item 2**). Remove the bowl (**Figure 18, Item 3**) from the sediment strainer by loosening the knurled nut retaining the bale (**Figure 18, Item 4**), and lifting the bale clear of the bowl. Avoid spilling fuel.



WARNING

Fuel must NOT be disposed of onto the ground, into water, wet lands, storm drains, or sanitary sewage systems. Uncontaminated liquid fuels must be collected during preparation for movement or maintenance, rather than absorbed into fuel absorbent materials. Contaminated liquid fuels must be collected (not absorbed into fuel absorbent materials) and turned in to your installation Environmental Office or Hazardous Waste Manager for proper disposal.

Fuel residue must be wiped from equipment surfaces and fuel connections using fuel absorbent mats. Absorbent mats containing fuel residue must be disposed of IAW with guidance provided by your installation Environmental Office or Hazardous Waste Manager. Improper disposal of liquid fuels or absorbent materials containing fuel residue is a violation of local, state, DoD, and federal regulations, and is subject both to civil citations and fines as well as criminal prosecution and fines.

27. Empty the bowl (**Figure 18, Item 3**) into a clean container, and tilt the heater for at least 30 seconds to allow any remaining fuel to be captured. Close the fuel drain fitting (**Figure 17, Item 1**).
28. Dispose of this fuel IAW unit SOP and local regulations.
29. Install the bowl (**Figure 18, Item 3**) onto the sediment strainer (**Figure 18, Item 2**) and retain in place with the bale (**Figure 18, Item 4**). Tighten the knurled nut to secure the bale onto the bowl. Refer to WP 0035 00 for information as needed.
30. Wipe all fuel from heater surfaces with fuel absorbent mats (**Figure 18, Item 1**). Ensure the heater fuel fittings have been wiped down as well. Install the cap (**Figure 18, Item 5**) on the heater fuel connection.

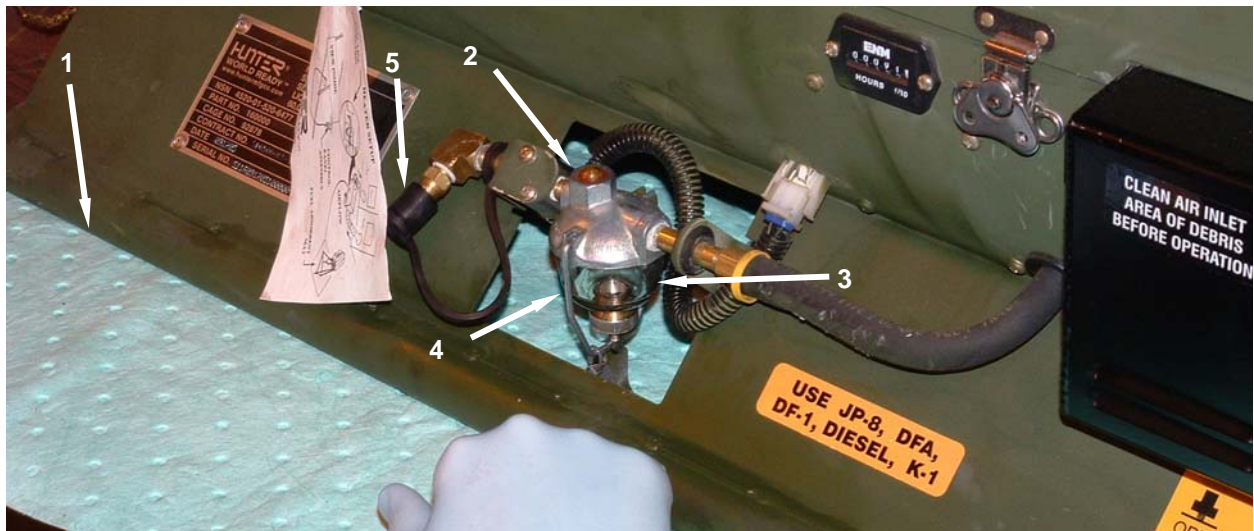

Figure 18. Prepare for Movement – Drain Sediment Bowl.

31. Disassemble the fuel can stand (**Figure 19, Item 1**) by removing the clip (**Figure 19, Item 2**), raising the two support arms (**Figure 19, Item 3**), and separating the lower legs (**Figure 19, Item 4**) from the upper portion of the stand. Place both the lower and upper sections of the stand together and wrap the straps around the stand to secure.

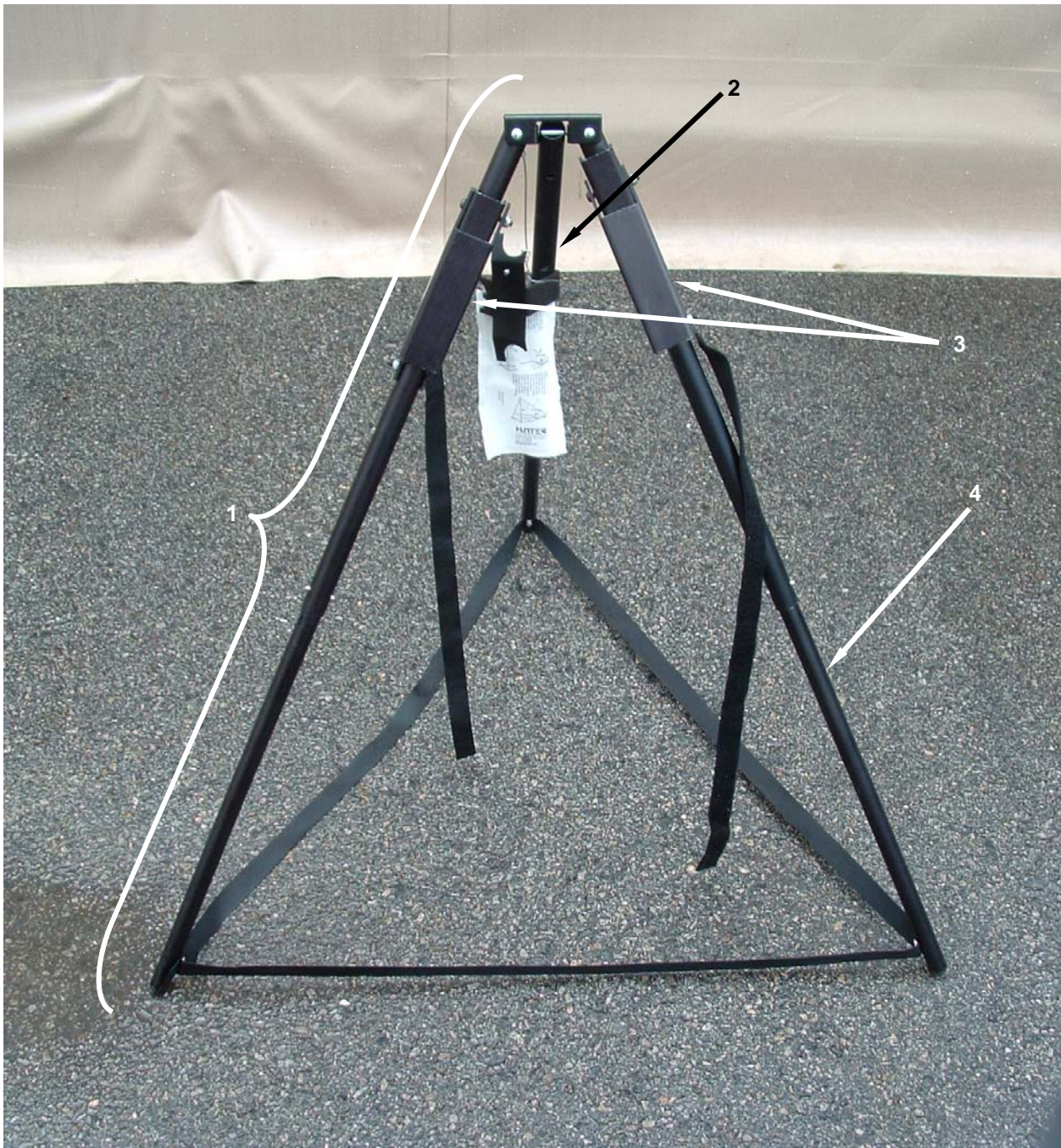

Figure 19. Prepare for Movement – Disassemble Fuel Can Stand.

32. Untie the straps securing both tent duct tunnels (**Figure 20, Item 1**) and remove both ducts (**Figure 20, Item 2**) from their respective tent duct tunnels.
33. Remove the in-tent controller (**Figure 20, Item 3**) from shelter and disconnect the in-tent controller cable (**Figure 20, Item 4**). Install the protective caps on the connectors of the in-tent controller and cable.
34. Secure both tent duct tunnels (**Figure 20, Item 1**) by closing off with tie straps.
35. Install the dust covers over the inlet and outlet duct adapters (**Figure 20, Item 5**).



Figure 20. Prepare for Movement – Secure Duct Tunnels.

36. Compress both ducts (**Figure 21, Item 1**) and stow in accessory bag (**Figure 21, Item 2**).
37. Stow the in-tent controller, the in-tent controller cable, the fuel can stand, and this TM inside the ducts (**Figure 21, Item 1**) in place in the accessory bag (**Figure 21, Item 2**).

CAUTION

Do not store fuel components in air ducts. Storage of fuel components within the air ducts may contaminate the ducts, making them unsuitable for air handling.

38. Place the Y adapter in the accessory bag (**Figure 21, Item 2**) outside of the ducts (**Figure 21, Item 1**).



WARNING

Excessive weight hazard. The Space Heater, Convective 60K BTU (SHC-60K) weighs approximately **118 pounds (53.5 kg)** with accessories and transit bag. Four persons must carry the unit, lifting with legs, not back, to prevent injury. Failure to do so may result in serious back or other muscular skeletal injuries.

39. Place the heater inside the heater transport bag (**Figure 21, Item 3**), and close the bag.
40. Place the gravity feed adapters and fuel hose in the heater transport bag (**Figure 21, Item 3**) with the heater. Close the bag.

CAUTION

Always store and transport the heater in the transport bag to prevent damage to the heater and potential loss of loose heater components.

41. Store and transport the packaged heater in the horizontal position. Do not stand it vertically on end.



Figure 21. Prepare for Movement – Final Packaging.

ADMINISTRATIVE STORAGE

1. Placement of equipment in administrative storage should be for short periods of time when a shortage of maintenance effort exists. Items should be in mission readiness within 24 hours or within the time factors as determined by the directing authority. During the storage period, appropriate maintenance records will be kept.
2. Before placing the equipment in administrative storage, current preventive maintenance checks and services should be completed, shortcomings and deficiencies should be corrected, and all Modification Work Orders (MWO) should be applied.
3. Inside storage is preferred for items selected for administrative storage. If inside storage is not available, trucks, vans, conex containers, and other containers may be used.

END OF WORK PACKAGE

**OPERATOR'S AND UNIT MAINTENANCE MANUAL
SPACE HEATER, CONVECTIVE 60K BTU (SHC-60K)
NSN 4520-01-520-6477
OPERATION UNDER UNUSUAL CONDITIONS**

SECURITY MEASURES FOR ELECTRONIC DATA

The SHC-60K requires no special security measures.

OPERATION IN EXTREME SAND, DUST, AND/OR HIGH WINDS



WARNING

The heater has been designed to operate in dusty or sandy conditions. However, some forms of very fine dusts may be explosive (e.g., flour, chaff, coal, etc.). Before operation of the heater in dusty conditions, an attempt should be made to identify the dust type to insure that it is not explosive in nature.

If possible, the heater should be positioned to minimize the amount of dust, sand, or any other material in the area that could be pulled into the heater by the fans (air flow is 500 cubic feet per minute (CFM) during normal operation of the heater).

When operating in conditions of extreme sand or dust, it is recommended that the air supply and return ducts (**Figure 1, Item 1**) be secured to the heater (**Figure 1, Item 2**) and the ducts securely connected to the tent.



WARNING

Always store fuel cans in a well-ventilated area as far away from open flames and other potential ignition sources as possible. Leaking or spilled fuels will create a fire danger-injuries/death and environmental damage. Fuel spills must be cleaned up in accordance with local requirements.

If high winds are expected, the fuel can stand (**Figure 1, Item 3**), ducts (**Figure 1, Item 1**) and the heater itself (**Figure 1, Item 2**) may require additional anchor or tiedowns to prevent high winds from shifting the equipment.

During refueling and at regular intervals between refueling, the heater (**Figure 1, Item 2**), ducts (**Figure 1, Item 1**), combustion air inlet (**Figure 1, Item 4**), and combustion exhaust (**Figure 1, Item 5**) should be inspected for a buildup of dust or sand that would cover the heater or block the ducts or pipes.

During refueling and at regular intervals between refueling, the sediment strainer (**Figure 1, Item 6**) should be visually checked for dirt or other contamination. If dirt or other contamination is present, the sediment strainer should be serviced in accordance with WP 0035 00 entitled "Solenoid Valve and Sediment Strainer Assembly."

OPERATION IN EXTREME RAIN, FREEZING RAIN, OR SNOW

When operating in conditions of extreme rain, freezing rain, or snow, it is recommended that the ducts (**Figure 2, Item 1**) be secured to the heater (**Figure 2, Item 2**) and securely connected to the tent.

Under no circumstances should the heater (**Figure 2, Item 2**) be positioned in standing water. Heater site should be graded slightly, if necessary, to insure that water runs away from heater and tent.

NOTE

The heater will not operate when tilt or grade is greater than 15 degrees, which is a 2.6 foot drop over a 10 foot span.

Ducts (**Figure 2, Item 1**), and the heater (**Figure 2, Item 2**) itself might need to be raised higher off the ground to prevent water from entering the heater, especially the base of the heater housing. The base contains three sealed compartments in which the battery, combustion blower, and electronic controller are located. These compartments must not be submerged in standing water. If the heater is to be raised above ground level, make sure that water cannot run along ducts or heater control assembly lead and find its way into the tent.

If high winds accompany rain, freezing rain, or snow, additional anchors or tiedowns may be required to prevent winds from shifting the equipment.



WARNING

Leaking or spilled fuels will create a fire danger-injuries/death and environmental damage. Fuel spills must be cleaned up in accordance with local requirements.

If high winds accompany the rain, freezing rain, or snow, the fuel can stand (**Figure 2, Item 3**) should be firmly anchored to the ground. (Tent stakes and line can be used as an improvised anchor and tiedown.)

During refueling and at regular intervals between refueling, the heater (**Figure 2, Item 2**), ducts (**Figure 2, Item 1**), combustion air inlet (**Figure 2, Item 4**), and combustion exhaust (**Figure 2, Item 5**) should be inspected for a buildup of snow, ice, dust, or sand that would cover the heater or block the ducts or pipes. Any buildup should be removed.

During refueling and at regular intervals between refueling, the sediment strainer (**Figure 2, Item 6**) of the heater should be visually checked for contamination. If dirt or other contamination is present, the sediment strainer should be serviced in accordance with WP 0035 00 entitled "Solenoid Valve and Sediment Strainer Assembly."

Special care should be used during refueling to prevent water, snow, sand, or dust contamination of fuel, fuel can, fuel hose, and fuel fittings.

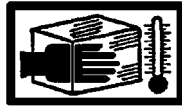

Figure 2. Operation in Extreme Rain, Freezing Rain, or Snow.

OPERATION IN EXTREME COLD (Temperatures Below -25°F [-31.7°C])**WARNING**

Do not touch cold metal parts with bare hands – always wear gloves. Exposed skin may adhere to cold metal parts, or produce frostbite can cause permanent injury to personnel, requiring medical attention to afflicted areas.

When operating in conditions of extreme rain, freezing rain, or snow, it is recommended that the ducts (**Figure 3, Item 1**) be secured to the heater (**Figure 3, Item 2**) and securely connected to the tent. Under no circumstances should the heater or the ducts be allowed to be covered with snow or ice.

Ducts (**Figure 3, Item 1**) and the heater (**Figure 3, Item 2**) itself may need to be raised higher off the ground to prevent snow from entering the heater.

If high winds accompany extreme cold, additional anchors or tiedowns may be required to prevent winds from shifting the equipment. (Tent stakes and line can be used as an improvised anchor and tiedown.)

**WARNING**

Leaking or spilled fuels will create a fire danger-injuries/death and environmental damage. Fuel spills must be cleaned up in accordance with local requirements.

If high winds accompany the snow, the fuel can stand (**Figure 3, Item 3**) should be firmly anchored to the ground.

During refueling and at regular intervals between refueling, the heater (**Figure 3, Item 2**), ducts (**Figure 3, Item 1**), combustion air inlet (**Figure 3, Item 4**), and combustion exhaust (**Figure 3, Item 5**) should be inspected for a buildup of snow, ice, dust, or sand that would cover the heater or block the ducts or pipes. Any buildup should be removed.

During refueling and at regular intervals between refueling, the sediment strainer (**Figure 3, Item 6**) of the heater should be visually checked for contamination. If dirt or other contamination is present, the sediment strainer should be serviced in accordance with WP 0035 00 entitled “Solenoid Valve and Sediment Strainer Assembly.”

Special care should be used during refueling to prevent snow and ice from contaminating fuel, fuel can, fuel lines, and fuel fittings.



Figure 3. Operation in Extreme Cold (Temperatures Below -25°F [-31.7°C]).

OPERATION IN MODERATE CLIMATES

When used in moderate climates, such as the southern United States, the SHC-60K may overheat the inside of the tent (temperatures in excess of 90°F). The in-tent controller responds with a number 10 fault code (tent over temperature). This causes the heater to shut down as soon as the “Battery Charged” light is illuminated.

To alleviate this problem, open the door and cool the interior of the tent as described for the fault code in WP 0022 00. If the problem persists, remove the heater inlet duct (**Figure 4, Item 1**) from the tent wall as shown in Figure 4. The inlet duct needs to remain attached to the heater to keep rain and snow from entering the heater body. The heater should be operated in this configuration until the air temperature decreases or the tent cannot be adequately heated. The return air duct may then be reinstalled in the tent wall.



Figure 4. Operation in Moderate Climate.

INTERIM NUCLEAR, BIOLOGICAL, AND CHEMICAL (NBC) DECONTAMINATION PROCEDURES

The SHC-60K is not required to be decontaminated in the event of an NBC attack. Shut down and cool the heater before performing any decontamination procedures on the attached tent or any nearby equipment.



WARNING

DO NOT SPRAY DS2 OR ANY OTHER COMBUSTIBLE DECONTAMINATION SOLUTIONS OR COMPOUNDS ON AN OPERATING HEATER OR STACK. DS2 has a flashpoint of 160 degrees F. Failure to observe safety precautions may result in serious injury or death to personnel.

EMERGENCY PROCEDURES

Limited Availability of JP-8

In the event JP-8 fuel is not available or in limited supply, use only the approved alternate fuels listed in Table 1, and ensure that the correct fuel is used for the ambient temperature.

Table 1. Approved Fuels.

	Ambient Temperature	Specification	Military Symbol
Primary Fuel	Above -60 °F (-51.1 °C)	MIL-T-83133	JP-8
Alternate Fuels	Above -60 °F (-51.1 °C)	VV-F-800	DF-A
	Above -60 °F (-51.1 °C)		K-1
	Above -25 °F (-31.7 °C)	MIL-T-83133	JP-5
	Above -25 °F (-31.7 °C)	VV-F-800	DF-1
	Above +20 °F (-6.7 °C)	VV-F-800	DF-2

Damage to Fuel Can, Gravity Feed Adapter, or Y Adapter

In the event of damage to a fuel can or a gravity feed adapter, the malfunctioning component may be isolated by closing the appropriate valve on the Y adapter. If the Y adapter is damaged or missing, the fuel hose may be directly connected to a gravity feed adapter.

END OF WORK PACKAGE

CHAPTER 3
TROUBLESHOOTING PROCEDURES
SPACE HEATER, CONVECTIVE 60K BTU (SHC-60K)

**OPERATOR'S AND UNIT MAINTENANCE
SPACE HEATER, CONVECTIVE 60K BTU (SHC-60K)
NSN 4520-01-520-6477
TROUBLESHOOTING INDEX**

TROUBLESHOOTING PROCEDURES

Table 1 lists common malfunctions that you may encounter with your equipment along with the troubleshooting procedure related to that malfunction. Refer to the list and locate the particular problem you are experiencing. Once you have found the problem in the list, go to the specific troubleshooting procedure detailed in the indicated work package. Perform the tests, inspections, and corrective actions in the order they appear in the troubleshooting procedure.

NOTE

When a malfunction occurs, the operator must wait for the heater to display a fault code, complete its post-purge cycle, and shut down automatically after 4 to 5 minutes. The SHC-60K incorporates built-in diagnostics which will identify the source of a problem.

The fault codes listed in Table 1 refer to codes displayed visually via the System Fault advisory light and heard audibly through the in-tent controller assembly. For example, if the System Fault advisory light flashes 5 times accompanied by 5 audible tones, this indicates a Fault Code 5 which, by referring to Table 1, indicates a "Glow Plug" problem. You would then refer directly to WP 0017 00 in the troubleshooting work package for detailed troubleshooting procedures on that subject.

This table cannot list all the malfunctions that may occur, all the tests and inspections needed to find the fault, or all the corrective actions needed to correct the fault. If the equipment malfunction is not listed or actions listed do not correct the fault, notify your supervisor and they will notify unit maintenance.

MALFUNCTION SYMPTOM INDEX

NOTE

Fault code 13 is not used.

Table 1. Malfunction Symptom Index.

Malfunction	Work Package
BATTERY CHARGED indicator does not light	WP 0009 00
BATTERY CHARGING indicator does not light	WP 0010 00
Black smoke from heater exhaust	WP 0011 00
Exhaust fumes in shelter	WP 0012 00
Fault Code 1 – Low battery voltage	WP 0013 00
Fault Code 2 – Combustion fan blower motor	WP 0014 00
Fault Code 3 – No flame	WP 0015 00
Fault Code 4 – Burner maintenance	WP 0016 00
Fault Code 5 – Glow plug	WP 0017 00
Fault Code 6 – TEG over-temperature	WP 0018 00
Fault Code 7 – Over voltage	WP 0019 00
Fault Code 8 – Tip-over	WP 0020 00
Fault Code 9 – Fin temp sensor	WP 0021 00
Fault Code 10 – Tent over temperature	WP 0022 00
Fault Code 11 – Low system voltage	WP 0023 00
Fault Code 12 – Inlet air over-temperature	WP 0024 00
Fault Code 14 – Fuel solenoid	WP 0025 00
Fault Code 15 – Fuel pump/manual thermostat reset	WP 0026 00
Fault Code 16 - Vent motor	WP 0027 00
Fault Code 17 – Inlet air temperature sensor	WP 0028 00
Fault Code 18 – Battery temperature sensor	WP 0029 00
Heater fails to start	WP 0030 00
Heater produces rumbling noise	WP 0031 00

END OF WORK PACKAGE

**OPERATOR'S AND UNIT MAINTENANCE
SPACE HEATER, CONVECTIVE, 60K BTU
NSN 4520-01-520-6477**

TROUBLESHOOTING PROCEDURES – BATTERY CHARGED INDICATOR DOES NOT LIGHT

INITIAL SETUP**Tools**

Tool Kit, General Mechanic's (Item 1, WP 0067 00)
 Battery Charging Adapter (Item 3, WP 0067 00)
 Commercial 12V DC Battery Charger (Item 4, WP 0067 00)
 NATO Charging System (Table 2, Item 5, WP 0067 00)

Personnel Required

One

Materials/Parts

Baled Rag, General (Item 3, WP 0092 00)
 Gasket (Item 6, WP 0092 00)
 Kit, Burner (Item 8, WP 0092 00)
 Kit, Float Assembly Repair (Item 9, WP 0092 00)
 Mat, Petroleum Absorbent (Item 11, WP 0092 00)
 Screen (Item 12, WP 0092 00)

Equipment Condition

Heater set-up and ready to operate IAW WP 0005 00 and WP 0006 00 for tests or inspections.

Heater shut down, all advisory lights off, fans stopped and heater cool before attempting corrective action(s)

GENERAL

WARNING

During operation, some metal components of the heater assembly, such as the louver on the outlet duct, the upper and lower heater housing assemblies, combustion exhaust pipe, etc., become very hot. Contact with bare skin can cause severe burn injuries.

Do not attempt service procedures on a burner that has recently been in operation. Switch heater ON/OFF control to the OFF position, wait until the green HEATER ON/ON-HOLD light is OFF, indicating the end of operation, post purge, and cool down cycle completion before performing these procedures to avoid the possibility of serious burns or damaging the heater.

NOTE

When troubleshooting, wait for the heater to display a fault code and shut down. Count the number of times the system fault light flashes as well as the number of audible tones heard. Record the number of times the system fault advisory light flashes and refer to the troubleshooting instructions later in this section for that specific fault code.

The troubleshooting table that follows lists common malfunctions that you may encounter with your equipment. Perform the tests, inspections, and corrective actions in the order they appear in the table. Refer to the malfunction symptom index for a listing of all the problems that may be encountered and proceed to the troubleshooting procedure indicated in the index.

This table cannot list all the malfunctions that may occur, all the tests and inspections needed to find the fault, or all the corrective actions needed to correct the fault. If the equipment malfunction is not listed or actions listed do not correct the fault, notify your supervisor and they will refer the equipment to unit maintenance.

TROUBLESHOOTING PROCEDURE**BATTERY CHARGED INDICATOR DOES NOT LIGHT****SYMPTOM**

Battery charged indicator does not light during operation.

MALFUNCTION

Battery has a low initial charge, or has been depleted due to unsuccessful attempts to start.

CORRECTIVE ACTION

Allow more time for the battery to charge. The battery may take up to 90 minutes to fully charge.

MALFUNCTION

Outside temperature low.

CORRECTIVE ACTION

Allow more time for the battery to charge. The battery may take up to 90 minutes to fully charge.

MALFUNCTION

Fuel flow is restricted or impaired.

CORRECTIVE ACTION

1. Check fuel supply to determine if the fuel can is full of the proper fuel for the temperature conditions. Refer to WP 0002 00, Table 2. Approved Fuels At Various Temperatures. Change the fuel to coincide with the appropriate temperature conditions.
2. Check the Y-adapter valves to determine if they are closed. Open valves if closed.
3. Check for kinks or loops in the fuel hose that may restrict the flow of fuel to the heater. Remove any kinks or loops in the fuel hose and make sure that it lies flat along the ground. Ensure that there are no kinks in the hose on the gravity feed adapter.
4. Ensure that all fuel quick disconnects connectors are securely attached.
5. Check the drain valve on the underside of the heater. Make sure the drain valve is in the closed position so fuel is not draining.
6. Check the umbrella valve on the gravity feed adapter to determine if it is sticking and not allowing air into the fuel can. Refer to WP 0033 00, Before PMCS, Gravity Feed Adapter.

7. Check sediment strainer assembly and make sure that sediment strainer is free of water, ice, dirt, or other foreign material. Refer to WP 0035 00 for sediment strainer assembly inspection instructions.

8. Check for blockage in solenoid valve and sediment strainer assembly. Place fuel absorbent mat under the sediment strainer assembly. Remove the sediment strainer bowl as described in WP 0035 00 and place a container to catch fuel under the open sediment strainer assembly. Turn on the heater and wait for the blower fans to spin up and the fuel solenoid to open. If little or no fuel exits the sediment strainer assembly there may be a blockage. Shut off immediately.

9. Check the float bowl to determine if the needle valve is sticking. Place a fuel mat or container under the float bowl drain valve. Open the drain valve. Turn on the heater and wait several minutes for the heater to start and begin pumping fuel. If there is no fuel flow or the fuel flow is low or unsteady, then the needle valve in the float bowl may be sticking. Refer to WP 0059 00 for instructions on cleaning the needle valve.

MALFUNCTION

Burner assembly has carbon build-up and requires cleaning.

CORRECTIVE ACTION

Refer to WP 0036 00 to inspect for carbon build-up and perform the cleaning procedure.

MALFUNCTION

Burner vaporizer pad reached its maximum life and requires replacement.

CORRECTIVE ACTION

Refer to WP 0036 00 for instructions on replacing the burner vaporizer pad.

MALFUNCTION

The burner is damaged or worn.

CORRECTIVE ACTION

Inspect the burner IAW WP 0060 00, and replace if damaged or worn.

MALFUNCTION

Fuel pump malfunction.

CORRECTIVE ACTION

Test the fuel pump IAW WP 0056 00. Replace an open or shorted fuel pump.

MALFUNCTION

Thermoelectric generator (TEG) malfunction.

CORRECTIVE ACTION

Test the thermoelectric generator (TEG) IAW WP 0061 00. Replace an open or shorted TEG.

END OF WORK PACKAGE

**OPERATOR'S AND UNIT MAINTENANCE
SPACE HEATER, CONVECTIVE, 60K BTU
NSN 4520-01-520-6477**

TROUBLESHOOTING PROCEDURES – BATTERY CHARGING INDICATOR DOES NOT LIGHT

INITIAL SETUP**Tools**

Tool Kit, General Mechanic's (Item 1, WP 0067 00)
 Battery Charging Adapter (Item 3, WP 0067 00)
 Commercial 12V DC Battery Charger (Item 4, WP 0067 00)
 NATO Charging System (Item 5, WP 0067 00)

Personnel Required

One

Materials/Parts

Baled Rag, General (Item 3, WP 0092 00)
 Gasket (Item 6, WP 0092 00)
 Kit, Burner (Item 8, WP 0092 00)
 Kit, Float Assembly Repair (Item 9, WP 0092 00)
 Mat, Petroleum Absorbent (Item 11, WP 0092 00)
 Screen (Item 12, WP 0092 00)

Equipment Condition

Heater set-up and ready to operate IAW WP 0005 00 and WP 0006 00 for tests or inspections.

Heater shut down, all advisory lights off, fans stopped and heater cool before attempting corrective action(s)

GENERAL

WARNING

During operation, some metal components of the heater assembly, such as the louver on the outlet duct, the upper and lower heater housing assemblies, combustion exhaust pipe, etc., become very hot. Contact with bare skin can cause severe burn injuries.

Do not attempt service procedures on a burner that has recently been in operation. Switch heater ON/OFF control to the OFF position, wait until the green HEATER ON/ON-HOLD light is OFF, indicating the end of operation, post purge, and cool down cycle completion before performing these procedures to avoid the possibility of serious burns or damaging the heater.

NOTE

When troubleshooting, wait for the heater to display a fault code and shut down. Count the number of times the system fault light flashes as well as the number of audible tones heard. Record the number of times the system fault advisory light flashes and refer to the troubleshooting instructions later in this section for that specific fault code.

The troubleshooting table that follows lists common malfunctions that you may encounter with your equipment. Perform the tests, inspections, and corrective actions in the order they appear in the table. Refer to the malfunction symptom index for a listing of all the problems that may be encountered and proceed to the troubleshooting procedure indicated in the index.

This table cannot list all the malfunctions that may occur, all the tests and inspections needed to find the fault, or all the corrective actions needed to correct the fault. If the equipment malfunction is not listed or actions listed do not correct the fault, notify your supervisor and they will refer the equipment to unit maintenance.

TROUBLESHOOTING PROCEDURE**BATTERY CHARGING INDICATOR DOES NOT LIGHT****SYMPTOM**

Battery charging light does not come on during operation.

MALFUNCTION

Battery connector loose.

CORRECTIVE ACTION

Firmly seat battery connector.

MALFUNCTION

Open fuses.

CORRECTIVE ACTION

Remove fuses from battery pack. Visually inspect the element inside the fuse to ensure both fuses are in good condition. If one or more fuse is bad or if in doubt, replace bad fuse(s) with spare fuse(s) located behind duct adapter at heater inlet assembly. Check the fuses for continuity IAW WP 0042 00.

MALFUNCTION

Vent openings on the front of the combustion air inlet cover are obstructed.

CORRECTIVE ACTION

Clear combustion inlet area of snow or any other obstructions.

MALFUNCTION

Combustion exhaust pipe is obstructed.

CORRECTIVE ACTION

Clear combustion exhaust pipe area of snow or other obstructions.

MALFUNCTION

Fuel flow is restricted or impaired.

CORRECTIVE ACTION

1. Check fuel supply to determine if the fuel can is full of the proper fuel for the temperature conditions. Refer to WP 0002 00, Table 2. Approved Fuels At Various Temperatures. Change the fuel to coincide with the appropriate temperature conditions.
2. Check the Y-adapter valves to determine if they are closed. Open valves if closed.

3. Check for kinks or loops in the fuel hose that may restrict the flow of fuel to the heater. Remove any kinks or loops in the fuel hose and make sure that it lies flat along the ground. Ensure that there are no kinks in the hose on the gravity feed adapter.
4. Ensure that all fuel quick disconnects connectors are securely attached.
5. Check the drain valve on the underside of the heater. Make sure the drain valve is in the closed position so fuel is not draining.
6. Check the umbrella valve on the gravity feed adapter to determine if it is sticking and not allowing air into the fuel can. Refer to WP 0033 00, Before PMCS, Gravity Feed Adapter.
7. Check sediment strainer assembly and make sure that sediment strainer is free of water, ice, dirt, or other foreign material. Refer to WP 0035 00 for sediment strainer assembly inspection instructions.
8. Check for blockage in solenoid valve and sediment strainer assembly. Place fuel absorbent mat under the sediment strainer assembly. Remove the sediment strainer bowl as described in WP 0035 00 and place a container to catch fuel under the open sediment strainer assembly. Turn on the heater and wait for the blower fans to spin up and the fuel solenoid to open. If little or no fuel exits the sediment strainer assembly there may be a blockage. Shut off immediately.
9. Check the float bowl to determine if the needle valve is sticking. Place a fuel mat or container under the float bowl drain valve. Open the drain valve. Turn on the heater and wait several minutes for the heater to start and begin pumping fuel. If there is no fuel flow or the fuel flow is low or unsteady, then the needle valve in the float bowl may be sticking. Refer to WP 0059 00 for instructions on cleaning the needle valve.

MALFUNCTION

Thermoelectric Generator (TEG) leads are loose in the modular connector.

CORRECTIVE ACTION

Tighten the lead connections in the modular connector. Refer to WP 0061 00 as needed.

MALFUNCTION

Burner assembly has carbon build-up and requires cleaning.

CORRECTIVE ACTION

Refer to WP 0036 00 to inspect for carbon build-up and perform the cleaning procedure.

MALFUNCTION

Burner vaporizer pad reached its maximum life and requires replacement.

CORRECTIVE ACTION

Refer to WP 0036 00 for instructions on replacing the burner vaporizer pad.

MALFUNCTION

Burner is damaged or worn.

CORRECTIVE ACTION

Inspect burner IAW WP 0060 00, and replace if damaged or worn.

MALFUNCTION

Fuel pump malfunction.

CORRECTIVE ACTION

Test the fuel pump IAW WP 0056 00. Replace an open or shorted fuel pump.

MALFUNCTION

Thermoelectric generator (TEG) malfunction.

CORRECTIVE ACTION

Test the thermoelectric generator (TEG) IAW WP 0061 00. Replace an open or shorted TEG.

END OF WORK PACKAGE

**OPERATOR'S AND UNIT MAINTENANCE
SPACE HEATER, CONVECTIVE, 60K BTU
NSN 4520-01-520-6477
TROUBLESHOOTING PROCEDURES – BLACK SMOKE FROM HEATER EXHAUST**

INITIAL SETUP**Tools**

Tool Kit, General Mechanic's (Item 1, WP 0067 00)
 Battery Charging Adapter (Item 3, WP 0067 00)
 Commercial 12V DC Battery Charger (Item 4, WP 0067 00)
 NATO Charging System (Item 5, WP 0067 00)

Personnel Required

One

Materials/Parts

Baled Rag, General (Item 3, WP 0092 00)
 Gasket (Item 6, WP 0092 00)
 Kit, Burner (Item 8, WP 0092 00)
 Kit, Float Assembly Repair (Item 9, WP 0092 00)
 Mat, Petroleum Absorbent (Item 11, WP 0092 00)
 Screen (Item 12, WP 0092 00)

Equipment Condition

Heater set-up and ready to operate IAW WP 0005 00 and WP 0006 00 for tests or inspections.

Heater shut down, all advisory lights off, fans stopped and heater cool before attempting corrective action(s)

GENERAL

WARNING

During operation, some metal components of the heater assembly, such as the louver on the outlet duct, the upper and lower heater housing assemblies, combustion exhaust pipe, etc., become very hot. Contact with bare skin can cause severe burn injuries.

Do not attempt service procedures on a burner that has recently been in operation. Switch heater ON/OFF control to the OFF position, wait until the green HEATER ON/ON-HOLD light is OFF, indicating the end of operation, post purge, and cool down cycle completion before performing these procedures to avoid the possibility of serious burns or damaging the heater.

NOTE

When troubleshooting, wait for the heater to display a fault code and shut down. Count the number of times the system fault light flashes as well as the number of audible tones heard. Record the number of times the system fault advisory light flashes and refer to the troubleshooting instructions later in this section for that specific fault code.

The troubleshooting table that follows lists common malfunctions that you may encounter with your equipment. Perform the tests, inspections, and corrective actions in the order they appear in the table. Refer to the malfunction symptom index for a listing of all the problems that may be encountered and proceed to the troubleshooting procedure indicated in the index.

This table cannot list all the malfunctions that may occur, all the tests and inspections needed to find the fault, or all the corrective actions needed to correct the fault. If the equipment malfunction is not listed or actions listed do not correct the fault, notify your supervisor and they will refer the equipment to a higher echelon maintenance.

TROUBLESHOOTING PROCEDURE**BLACK SMOKE FROM HEATER EXHAUST****SYMPTOM**

Heater emits black smoke continuously during operation.

MALFUNCTION

Vent openings on the front of the combustion air inlet cover are obstructed.

CORRECTIVE ACTION

Clear combustion inlet area of snow or any other obstructions.

MALFUNCTION

Combustion exhaust pipe is obstructed.

CORRECTIVE ACTION

Clear combustion exhaust pipe area of snow or other obstructions.

MALFUNCTION

Incorrect fuel is being used for the outside temperature where the heater is being operated.

CORRECTIVE ACTION

Refer to WP 0002 00, Table 2. Approved Fuels At Various Temperatures. Use the appropriate fuel for the temperature in which the heater is operating.

MALFUNCTION

Water or other contaminants in the fuel supply.

CORRECTIVE ACTION

Replace contaminated fuel with new can of clean, uncontaminated fuel.

MALFUNCTION

Heater is running on diesel fuel.

CORRECTIVE ACTION

Change fuel to JP-8. If fuel cannot be changed to JP-8, then the burner may require cleaning every 750 to 1000 hours of running time. Refer to WP 0036 00.

MALFUNCTION

Burner assembly has carbon build-up and requires cleaning.

CORRECTIVE ACTION

Refer to WP 0036 00 to inspect for carbon build-up and perform the cleaning procedure.

MALFUNCTION

Burner vaporizer pad reached its maximum life and requires replacement.

CORRECTIVE ACTION

Refer to WP 0036 00 for instructions on replacing the burner vaporizer pad.

MALFUNCTION

Burner is damaged or worn.

CORRECTIVE ACTION

Inspect burner IAW WP 0060 00, and replace if damaged or worn.

END OF WORK PACKAGE

**OPERATOR'S AND UNIT MAINTENANCE
SPACE HEATER, CONVECTIVE, 60K BTU
NSN 4520-01-520-6477**

TROUBLESHOOTING PROCEDURES – EXHAUST FUMES PRESENT IN SHELTER

INITIAL SETUP**Tools**

Tool Kit, General Mechanic's (Item 1, WP 0067 00)
 Battery Charging Adapter (Item 3, WP 0067 00)
 Commercial 12V DC Battery Charger (Item 4, WP 0067 00)
 NATO Charging System (Item 5, WP 0067 00)

Personnel Required

One

Materials/Parts

Baled Rag, General (Item 3, WP 0092 00)
 Mat, Petroleum Absorbent (Item 11, WP 0092 00)
 Seal, Graphite Ribbon (Item 13, WP 0092 00)
 Tape, Duct (Item 15, WP 0092 00)

Equipment Condition

Heater set-up and ready to operate IAW WP 0005 00 and WP 0006 00 for tests or inspections.

Heater shut down, all advisory lights off, fans stopped and heater cool before attempting corrective action(s)

GENERAL

WARNING

During operation, some metal components of the heater assembly, such as the louver on the outlet duct, the upper and lower heater housing assemblies, combustion exhaust pipe, etc., become very hot. Contact with bare skin can cause severe burn injuries.

Do not attempt service procedures on a burner that has recently been in operation. Switch heater ON/OFF control to the OFF position, wait until the green HEATER ON/ON-HOLD light is OFF, indicating the end of operation, post purge, and cool down cycle completion before performing these procedures to avoid the possibility of serious burns or damaging the heater.

NOTE

When troubleshooting, wait for the heater to display a fault code and shut down. Count the number of times the system fault light flashes as well as the number of audible tones heard. Record the number of times the system fault advisory light flashes and refer to the troubleshooting instructions later in this section for that specific fault code.

The troubleshooting table that follows lists common malfunctions that you may encounter with your equipment. Perform the tests, inspections, and corrective actions in the order they appear in the table. Refer to the malfunction symptom index for a listing of all the problems that may be encountered and proceed to the troubleshooting procedure indicated in the index.

This table cannot list all the malfunctions that may occur, all the tests and inspections needed to find the fault, or all the corrective actions needed to correct the fault. If the equipment malfunction is not listed or actions listed do not correct the fault, notify your supervisor and they will refer the equipment to unit maintenance.

TROUBLESHOOTING PROCEDURE**EXHAUST FUMES PRESENT IN SHELTER****SYMPTOM**

Strong odor of heater exhaust in tent.

**WARNING**

Evacuate the tent immediately if there is any indication that exhaust gases are entering the tent. Carbon monoxide is a gas without color, smell, or taste, but can kill you. Breathing carbon monoxide may produce symptoms of headache, dizziness, loss of muscular control, a sleepy feeling, and unconsciousness or coma. Brain damage or death can result from heavy exposure. Carbon monoxide is present in the exhaust fumes of any fuel-burning heaters and internal combustion engines. Fatal concentrations of carbon monoxide will occur if the Space Heater, Convective 60K BTU (SHC-60K), or any fuel burning space heater, is operated in an enclosed area such as a tent or structure.

MALFUNCTION

Flexible air ducts loose or incorrectly attached.

CORRECTIVE ACTION

Ensure air ducts are securely connected IAW WP 0005 00.

MALFUNCTION

Flexible air ducts damaged.

CORRECTIVE ACTION

Repair ducts IAW WP 0064 00. Replace unserviceable ducts.

MALFUNCTION

High winds forcing heater exhaust into tent.

CORRECTIVE ACTION

Move heater if practical. Shield heater from wind with a vehicle, container, or other field expedient windbreak.

MALFUNCTION

Separate source of exhaust fumes (vehicles, generators).

CORRECTIVE ACTION

Isolate and remove source of exhaust fumes, or relocate tent and heater.

MALFUNCTION

Loose flange clamps or faulty flange clamp seals.

CORRECTIVE ACTION

Inspect fiberglass rope seals and replace as necessary IAW WP 0060 00, WP 0061 00 and WP 0062. Install new graphite tape at flanges IAW WP 0060 00, WP 0061 00 and WP 0062 00 as required. Ensure flange clamps are tight and in good repair.

MALFUNCTION

Damaged heat exchanger.

CORRECTIVE ACTION

Inspect heat exchanger IAW WP 0062 00, and replace if necessary.

END OF WORK PACKAGE

**OPERATOR'S AND UNIT MAINTENANCE
SPACE HEATER, CONVECTIVE, 60K BTU
NSN 4520-01-520-6477
TROUBLESHOOTING PROCEDURES – FAULT CODE 1**

INITIAL SETUP

Tools

Tool Kit, General Mechanic's (Item 1, WP 0067 00)
 Battery Charging Adapter (Item 3, WP 0067 00)
 Commercial 12V DC Battery Charger (Item 4, WP 0067 00)
 NATO Charging System (Item 5, WP 0067 00)

Personnel Required

One

Materials/Parts

Baled Rag, General (Item 3, WP 0092 00)
 Mat, Petroleum Absorbent (Item 11, WP 0092 00)

Equipment Condition

Heater set-up and ready to operate IAW WP 0005 00 and WP 0006 00 for tests or inspections.

Heater shut down, all advisory lights off, fans stopped and heater cool before attempting corrective action(s)

GENERAL



WARNING

During operation, some metal components of the heater assembly, such as the louver on the outlet duct, the upper and lower heater housing assemblies, combustion exhaust pipe, etc., become very hot. Contact with bare skin can cause severe burn injuries.

Do not attempt service procedures on a burner that has recently been in operation. Switch heater ON/OFF control to the OFF position, wait until the green HEATER ON/ON-HOLD light is OFF, indicating the end of operation, post purge, and cool down cycle completion before performing these procedures to avoid the possibility of serious burns or damaging the heater.

NOTE

When troubleshooting, wait for the heater to display a fault code and shut down. Count the number of times the system fault light flashes as well as the number of audible tones heard. Record the number of times the system fault advisory light flashes and refer to the troubleshooting instructions later in this section for that specific fault code.

The troubleshooting table that follows lists common malfunctions that you may encounter with your equipment. Perform the tests, inspections, and corrective actions in the order they appear in the table. Refer to the malfunction symptom index for a listing of all the problems that may be encountered and proceed to the troubleshooting procedure indicated in the index.

This table cannot list all the malfunctions that may occur, all the tests and inspections needed to find the fault, or all the corrective actions needed to correct the fault. If the equipment malfunction is not listed or actions listed do not correct the fault, notify your supervisor and they will refer the equipment to unit maintenance.

TROUBLESHOOTING PROCEDURE**FAULT CODE 1 – LOW BATTERY VOLTAGE****SYMPTOM**

Heater inoperative, the system fault light repeatedly flashes one time, and repeatedly sounds one audible warning tone.

MALFUNCTION

Open fuses.

CORRECTIVE ACTION

Remove fuses from battery pack. Visually inspect the element inside the fuse to ensure both fuses are in good condition. If one or more fuse is bad or if in doubt, replace bad fuse(s) with spare fuse(s) located behind duct adapter at heater inlet assembly. Test fuses for continuity IAW WP 0043 00.

MALFUNCTION

Battery requires charge.

CORRECTIVE ACTION

Charge the battery with either the NATO charging system IAW WP 0006 00, or with a battery charger and charging adapter IAW WP 0043 00.

MALFUNCTION

Battery damaged or malfunctioning.

CORRECTIVE ACTION

Test the battery, and replace if necessary IAW WP 0043 00.

END OF WORK PACKAGE

**OPERATOR'S AND UNIT MAINTENANCE
SPACE HEATER, CONVECTIVE, 60K BTU
NSN 4520-01-520-6477
TROUBLESHOOTING PROCEDURES - FAULT CODE 2**

INITIAL SETUP

Tools

Tool Kit, General Mechanic's (Item 1, WP 0067 00)

Personnel Required

One

Materials/Parts

Baled Rag, General (Item 3, WP 0092 00)
Mat, Petroleum Absorbent (Item 11, WP 0092 00)

Equipment Condition

Heater set-up and ready to operate IAW WP 0005 00 and WP 0006 00 for tests or inspections.

Heater shut down, all advisory lights off, fans stopped and heater cool before attempting corrective action(s)

GENERAL



WARNING

During operation, some metal components of the heater assembly, such as the louver on the outlet duct, the upper and lower heater housing assemblies, combustion exhaust pipe, etc., become very hot. Contact with bare skin can cause severe burn injuries.

Do not attempt service procedures on a burner that has recently been in operation. Switch heater ON/OFF control to the OFF position, wait until the green HEATER ON/ON-HOLD light is OFF, indicating the end of operation, post purge, and cool down cycle completion before performing these procedures to avoid the possibility of serious burns or damaging the heater.

NOTE

When troubleshooting, wait for the heater to display a fault code and shut down. Count the number of times the system fault light flashes as well as the number of audible tones heard. Record the number of times the system fault advisory light flashes and refer to the troubleshooting instructions later in this section for that specific fault code.

The troubleshooting table that follows lists common malfunctions that you may encounter with your equipment. Perform the tests, inspections, and corrective actions in the order they appear in the table. Refer to the malfunction symptom index for a listing of all the problems that may be encountered and proceed to the troubleshooting procedure indicated in the index.

This table cannot list all the malfunctions that may occur, all the tests and inspections needed to find the fault, or all the corrective actions needed to correct the fault. If the equipment malfunction is not listed or actions listed do not correct the fault, notify your supervisor and they will refer the equipment to unit maintenance.

TROUBLESHOOTING PROCEDURE**FAULT CODE 2 – COMBUSTION FAN BLOWER MOTOR****SYMPTOM**

Heater inoperative, the system fault light repeatedly flashes two times, and repeatedly sounds two audible warning tones.

MALFUNCTION

Motor locked by ice or snow.

CORRECTIVE ACTION

Place the heater in a warm area that would allow the snow or ice to melt and free the motor. Inspect for indications that the snow or ice has melted and attempt a restart after setting up IAW WP 0005 00.

MALFUNCTION

Loose motor connections or damaged motor leads.

CORRECTIVE ACTION

Reconnect the motor connections. Inspect the wire leads to the motor, and repair damaged wiring IAW WP 0040 00.

MALFUNCTION

Open or shorted combustion fan blower motor.

CORRECTIVE ACTION

Test the combustion fan blower motor IAW WP 0050 00. Replace if necessary.

END OF WORK PACKAGE

**OPERATOR'S AND UNIT MAINTENANCE
SPACE HEATER, CONVECTIVE, 60K BTU
NSN 4520-01-520-6477
TROUBLESHOOTING PROCEDURES - FAULT CODE 3**

INITIAL SETUP

Tools

Tool Kit, General Mechanic's (Item 1, WP 0067 00)
 Battery Charging Adapter (Item 3, WP 0067 00)
 Commercial 12V DC Battery Charger (Item 4, WP 0067 00)
 NATO Charging System (Item 5, WP 0067 00)

Personnel Required

One

Materials/Parts

Baled Rag, General (Item 3, WP 0092 00)
 Gasket (Item 6, WP 0092 00)
 Kit, Burner (Item 8, WP 0092 00)
 Kit, Float Assembly Repair (Item 9, WP 0092 00)
 Mat, Petroleum Absorbent (Item 11, WP 0092 00)
 Screen (Item 12, WP 0092 00)

Equipment Condition

Heater set-up and ready to operate IAW WP 0005 00 and WP 0006 00 for tests or inspections.

Heater shut down, all advisory lights off, fans stopped and heater cool before attempting corrective action(s)

GENERAL



WARNING

During operation, some metal components of the heater assembly, such as the louver on the outlet duct, the upper and lower heater housing assemblies, combustion exhaust pipe, etc., become very hot. Contact with bare skin can cause severe burn injuries.

Do not attempt service procedures on a burner that has recently been in operation. Switch heater ON/OFF control to the OFF position, wait until the green HEATER ON/ON-HOLD light is OFF, indicating the end of operation, post purge, and cool down cycle completion before performing these procedures to avoid the possibility of serious burns or damaging the heater.

NOTE

When troubleshooting, wait for the heater to display a fault code and shut down. Count the number of times the system fault light flashes as well as the number of audible tones heard. Record the number of times the system fault advisory light flashes and refer to the troubleshooting instructions later in this section for that specific fault code.

The troubleshooting table that follows lists common malfunctions that you may encounter with your equipment. Perform the tests, inspections, and corrective actions in the order they appear in the table. Refer to the malfunction symptom index for a listing of all the problems that may be encountered and proceed to the troubleshooting procedure indicated in the index.

This table cannot list all the malfunctions that may occur, all the tests and inspections needed to find the fault, or all the corrective actions needed to correct the fault. If the equipment malfunction is not listed or actions listed do not correct the fault, notify your supervisor and they will refer the equipment to unit maintenance.

TROUBLESHOOTING PROCEDURE

FAULT CODE 3 - NO FLAME

SYMPTOM

Heater inoperative, the system fault light repeatedly flashes three times, and repeatedly sounds three audible warning tones.

MALFUNCTION

Vent openings on the front of the combustion air inlet cover are obstructed.

CORRECTIVE ACTION

Clear combustion inlet area of snow or any other obstructions.

MALFUNCTION

Combustion exhaust pipe is obstructed.

CORRECTIVE ACTION

Clear combustion exhaust pipe area of snow or other obstructions.

MALFUNCTION

Fuel supply exhausted.

CORRECTIVE ACTION

Refill fuel cans with JP-8 or approved fuel IAW WP 0006 00. If JP-8 is not used, ensure the approved fuel is appropriate for the outside temperature.

MALFUNCTION

Fuel flow is restricted or impaired.

CORRECTIVE ACTION

1. Check fuel supply to determine if the fuel can is full of the proper fuel for the temperature conditions. Refer to WP 0002 00, Table 2. Approved Fuels At Various Temperatures. Change the fuel to coincide with the appropriate temperature conditions.
2. Check the Y-adaptor valves to determine if they are closed. Open valves if closed.

3. Check for kinks or loops in the fuel hose that may restrict the flow of fuel to the heater. Remove any kinks or loops in the fuel hose and make sure that it lies flat along the ground. Ensure that there are no kinks in the hose on the gravity feed adapter.
4. Ensure that all fuel quick disconnects connectors are securely attached.
5. Check the drain valve on the underside of the heater. Make sure the drain valve is in the closed position so fuel is not draining.
6. Check the umbrella valve on the gravity feed adapter to determine if it is sticking and not allowing air into the fuel can. Refer to WP 0011 00, Before PMCS, Gravity Feed Adapter.
7. Check sediment strainer assembly and make sure that sediment strainer is free of water, ice, dirt, or other foreign material. Refer to WP 0035 00 for sediment strainer assembly inspection instructions.
8. Check for blockage in solenoid valve and sediment strainer assembly. Place fuel absorbent mat under the sediment strainer assembly. Remove the sediment strainer bowl as described in WP 0035 00 and place a container to catch fuel under the open sediment strainer assembly. Turn on the heater and wait for the blower fans to spin up and the fuel solenoid to open. If little or no fuel exits the sediment strainer assembly there may be a blockage. Shut off immediately.
9. Check the float bowl to determine if the needle valve is sticking. Place a fuel mat or container under the float bowl drain valve. Open the drain valve. Turn on the heater and wait several minutes for the heater to start and begin pumping fuel. If there is no fuel flow or the fuel flow is low or unsteady, then the needle valve in the float bowl may be sticking. Refer to WP 0059 00 for instructions on cleaning the needle valve.

MALFUNCTION

Flame sensor sooted or iced over.

CORRECTIVE ACTION

Clean or replace the flame sensor IAW WP 0037 00.

MALFUNCTION

Burner assembly has carbon build-up.

CORRECTIVE ACTION

Inspect and clean the burner assembly IAW WP 0036 00.

MALFUNCTION

Burner vaporizer pad reached its maximum life and requires replacement.

CORRECTIVE ACTION

Refer to WP 0036 00 for instructions on replacing the burner vaporizer pad.

MALFUNCTION

Burner fuel inlet is obstructed.

CORRECTIVE ACTION

Clear the obstruction. Refer to WP 0060 00 as needed.

MALFUNCTION

Burner is damaged or worn.

CORRECTIVE ACTION

Inspect burner IAW WP 0060 00, and replace if damaged or worn.

END OF WORK PACKAGE

**OPERATOR'S AND UNIT MAINTENANCE
SPACE HEATER, CONVECTIVE, 60K BTU
NSN 4520-01-520-6477
TROUBLESHOOTING PROCEDURES - FAULT CODE 4**

INITIAL SETUP**Tools**

Tool Kit, General Mechanic's (Item 1, WP 0067 00)

Personnel Required

One

Materials/Parts

Baled Rag, General (Item 3, WP 0092 00)

Kit, Burner (Item 8, WP 0092 00)

Mat, Petroleum Absorbent (Item 11, WP 0092 00)

Equipment Condition

Heater set-up and ready to operate IAW WP 0005 00 and WP 0006 00 for tests or inspections.

Heater shut down, all advisory lights off, fans stopped and heater cool before attempting corrective action(s)

GENERAL

WARNING

During operation, some metal components of the heater assembly, such as the louver on the outlet duct, the upper and lower heater housing assemblies, combustion exhaust pipe, etc., become very hot. Contact with bare skin can cause severe burn injuries.

Do not attempt service procedures on a burner that has recently been in operation. Switch heater ON/OFF control to the OFF position, wait until the green HEATER ON/ON-HOLD light is OFF, indicating the end of operation, post purge, and cool down cycle completion before performing these procedures to avoid the possibility of serious burns or damaging the heater.

NOTE

When troubleshooting, wait for the heater to display a fault code and shut down. Count the number of times the system fault light flashes as well as the number of audible tones heard. Record the number of times the system fault advisory light flashes and refer to the troubleshooting instructions later in this section for that specific fault code.

The troubleshooting table that follows lists common malfunctions that you may encounter with your equipment. Perform the tests, inspections, and corrective actions in the order they appear in the table. Refer to the malfunction symptom index for a listing of all the problems that may be encountered and proceed to the troubleshooting procedure indicated in the index.

This table cannot list all the malfunctions that may occur, all the tests and inspections needed to find the fault, or all the corrective actions needed to correct the fault. If the equipment malfunction is not listed or actions listed do not correct the fault, notify your supervisor and they will refer the equipment to unit maintenance.

TROUBLESHOOTING PROCEDURE**FAULT CODE 4 – BURNER MAINTENANCE****SYMPTOM**

Heater inoperative, the system fault light repeatedly flashes four times, and repeatedly sounds four audible warning tones.

MALFUNCTION

Improper fuel used.

CORRECTIVE ACTION

Refill fuel cans with JP-8 or approved fuel IAW WP 0006 00. If JP-8 is not used, ensure the approved fuel is appropriate for the outside temperature.

MALFUNCTION

Vent openings on the front of the combustion air inlet cover are obstructed.

CORRECTIVE ACTION

Clear combustion inlet area of snow or any other obstructions.

MALFUNCTION

Combustion exhaust pipe is obstructed.

CORRECTIVE ACTION

Clear combustion exhaust pipe area of snow or other obstructions.

MALFUNCTION

Flame sensor sooted or iced over.

CORRECTIVE ACTION

Clean or replace the flame sensor IAW WP 0037 00.

MALFUNCTION

Burner assembly has carbon build-up.

CORRECTIVE ACTION

Inspect and clean the burner assembly IAW WP 0036 00.

MALFUNCTION

Burner vaporizer pad (wick) is damaged or has reached the end of its service life (1000 hours).

CORRECTIVE ACTION

Replace the burner vaporizer pad IAW WP 0036 00.

MALFUNCTION

Burner is damaged or worn.

CORRECTIVE ACTION

Inspect burner IAW WP 0060 00, and replace if damaged or worn.

END OF WORK PACKAGE

**OPERATOR'S AND UNIT MAINTENANCE
SPACE HEATER, CONVECTIVE, 60K BTU
NSN 4520-01-520-6477
TROUBLESHOOTING PROCEDURES - FAULT CODE 5**

INITIAL SETUP**Tools**

Tool Kit, General Mechanic's (Item 1, WP 0067 00)

Personnel Required

One

Materials/Parts

Baled Rag, General (Item 3, WP 0092 00)
Mat, Petroleum Absorbent (Item 11, WP 0092 00)
Wire Markers (Item 19, WP 0092 00)

Equipment Condition

Heater set-up and ready to operate IAW WP 0005 00 and WP 0006 00 for tests or inspections.

Heater shut down, all advisory lights off, fans stopped and heater cool before attempting corrective action(s)

GENERAL

WARNING

During operation, some metal components of the heater assembly, such as the louver on the outlet duct, the upper and lower heater housing assemblies, combustion exhaust pipe, etc., become very hot. Contact with bare skin can cause severe burn injuries.

Do not attempt service procedures on a burner that has recently been in operation. Switch heater ON/OFF control to the OFF position, wait until the green HEATER ON/ON-HOLD light is OFF, indicating the end of operation, post purge, and cool down cycle completion before performing these procedures to avoid the possibility of serious burns or damaging the heater.

NOTE

When troubleshooting, wait for the heater to display a fault code and shut down. Count the number of times the system fault light flashes as well as the number of audible tones heard. Record the number of times the system fault advisory light flashes and refer to the troubleshooting instructions later in this section for that specific fault code.

The troubleshooting table that follows lists common malfunctions that you may encounter with your equipment. Perform the tests, inspections, and corrective actions in the order they appear in the table. Refer to the malfunction symptom index for a listing of all the problems that may be encountered and proceed to the troubleshooting procedure indicated in the index.

This table cannot list all the malfunctions that may occur, all the tests and inspections needed to find the fault, or all the corrective actions needed to correct the fault. If the equipment malfunction is not listed or actions listed do not correct the fault, notify your supervisor and they will refer the equipment to unit maintenance.

TROUBLESHOOTING PROCEDURE**FAULT CODE 5 – GLOW PLUG****SYMPTOM**

Heater inoperative, the system fault light repeatedly flashes five times, and repeatedly sounds five audible warning tones.

MALFUNCTION

Loose glow plug connection.

CORRECTIVE ACTION

Remove the upper housing assembly and verify that the wire leading to the glow plug is securely attached. Reconnect if necessary. Refer to WP 0038 00 as required.

MALFUNCTION

Open or shorted glow plug wiring.

CORRECTIVE ACTION

Remove the upper housing assembly and verify that the wire leading to the glow plug is not damaged in any way. Repair wiring IAW WP 0040 00 as required.

MALFUNCTION

Open or shorted glow plug.

CORRECTIVE ACTION

Replace the glow plug IAW WP 0038 00.

END OF WORK PACKAGE

**OPERATOR'S AND UNIT MAINTENANCE
SPACE HEATER, CONVECTIVE, 60K BTU
NSN 4520-01-520-6477
TROUBLESHOOTING PROCEDURES – FAULT CODE 6**

INITIAL SETUP**Tools**

Tool Kit, General Mechanic's (Item 1, WP 0067 00)

Personnel Required

One

Materials/Parts

Baled Rag, General (Item 3, WP 0092 00)

Mat, Petroleum Absorbent (Item 11, WP 0092 00)

Equipment Condition

Heater set-up and ready to operate IAW WP 0005 00 and WP 0006 00 for tests or inspections.

Heater shut down, all advisory lights off, fans stopped and heater cool before attempting corrective action(s)

GENERAL

WARNING

During operation, some metal components of the heater assembly, such as the louver on the outlet duct, the upper and lower heater housing assemblies, combustion exhaust pipe, etc., become very hot. Contact with bare skin can cause severe burn injuries.

Do not attempt service procedures on a burner that has recently been in operation. Switch heater ON/OFF control to the OFF position, wait until the green HEATER ON/ON-HOLD light is OFF, indicating the end of operation, post purge, and cool down cycle completion before performing these procedures to avoid the possibility of serious burns or damaging the heater.

NOTE

When troubleshooting, wait for the heater to display a fault code and shut down. Count the number of times the system fault light flashes as well as the number of audible tones heard. Record the number of times the system fault advisory light flashes and refer to the troubleshooting instructions later in this section for that specific fault code.

The troubleshooting table that follows lists common malfunctions that you may encounter with your equipment. Perform the tests, inspections, and corrective actions in the order they appear in the table. Refer to the malfunction symptom index for a listing of all the problems that may be encountered and proceed to the troubleshooting procedure indicated in the index.

This table cannot list all the malfunctions that may occur, all the tests and inspections needed to find the fault, or all the corrective actions needed to correct the fault. If the equipment malfunction is not listed or actions listed do not correct the fault, notify your supervisor and they will refer the equipment to unit maintenance.

TROUBLESHOOTING PROCEDURE**FAULT CODE 6 – TEG OVER TEMPERATURE****SYMPTOM**

Heater inoperative, the system fault light repeatedly flashes six times, and repeatedly sounds six audible warning tones.

MALFUNCTION

Thermoelectric generator (TEG) has overheated.

CORRECTIVE ACTION

Remove the upper housing assembly and inspect the fins on the TEG to ensure that there is no lint, grass, or other debris that would prevent air from flowing freely through the fins.

MALFUNCTION

Obstructions at the heated air outlet or inlet duct.

CORRECTIVE ACTION

Remove any obstructions at the heated air outlet or inlet duct that may be restricting free air movement.

MALFUNCTION

Heater ducts are obstructed or crushed by the tent wall.

CORRECTIVE ACTION

Install a Tent Wall Modification Kit. Refer to instructions in WP 0005 00.

MALFUNCTION

TEG sensor disconnected or malfunctioning.

CORRECTIVE ACTION

Ensure the TEG sensor connector is securely engaged. Inspect the wire for nicks, cuts, breaks, or abrasions that may cause an open or a short. Refer to WP 0040 00 for instructions on inspecting wires and connectors. Test the TEG sensor IAW WP 0061 00, and replace if necessary.

END OF WORK PACKAGE

**OPERATOR'S AND UNIT MAINTENANCE
SPACE HEATER, CONVECTIVE, 60K BTU
NSN 4520-01-520-6477
TROUBLESHOOTING PROCEDURES - FAULT CODE 7**

INITIAL SETUP

Tools

Tool Kit, General Mechanic's (Item 1, WP 0067 00)

Personnel Required

One

Materials/Parts

Baled Rag, General (Item 3, WP 0092 00)
Mat, Petroleum Absorbent (Item 11, WP 0092 00)

Equipment Condition

Heater set-up and ready to operate IAW WP 0005 00 and WP 0006 00 for tests or inspections.

Heater shut down, all advisory lights off, fans stopped and heater cool before attempting corrective action(s)

GENERAL



WARNING

During operation, some metal components of the heater assembly, such as the louver on the outlet duct, the upper and lower heater housing assemblies, combustion exhaust pipe, etc., become very hot. Contact with bare skin can cause severe burn injuries.

Do not attempt service procedures on a burner that has recently been in operation. Switch heater ON/OFF control to the OFF position, wait until the green HEATER ON/ON-HOLD light is OFF, indicating the end of operation, post purge, and cool down cycle completion before performing these procedures to avoid the possibility of serious burns or damaging the heater.

NOTE

When troubleshooting, wait for the heater to display a fault code and shut down. Count the number of times the system fault light flashes as well as the number of audible tones heard. Record the number of times the system fault advisory light flashes and refer to the troubleshooting instructions later in this section for that specific fault code.

The troubleshooting table that follows lists common malfunctions that you may encounter with your equipment. Perform the tests, inspections, and corrective actions in the order they appear in the table. Refer to the malfunction symptom index for a listing of all the problems that may be encountered and proceed to the troubleshooting procedure indicated in the index.

This table cannot list all the malfunctions that may occur, all the tests and inspections needed to find the fault, or all the corrective actions needed to correct the fault. If the equipment malfunction is not listed or actions listed do not correct the fault, notify your supervisor and they will refer the equipment to unit maintenance.

TROUBLESHOOTING PROCEDURE**FAULT CODE 7 – OVER VOLTAGE****SYMPTOM**

Heater inoperative, the system fault light repeatedly flashes seven times, and repeatedly sounds seven audible warning tones.

MALFUNCTION

Load bank has been disconnected.

CORRECTIVE ACTION

Verify the load bank connector is securely attached and not damaged in any way. Check the wire for breaks, cuts, abrasions, or nicks that may cause an open or short. If wire problems are identified, refer to WP 0040 00 for instructions on repairing wires.

MALFUNCTION

Load bank open or shorted.

CORRECTIVE ACTION

Test the load bank resistance per the instructions in WP 0044 00. The load bank resistance should be 1.33 Ohms +/-0.15 Ohms. Replace an open or shorted load bank.

MALFUNCTION

Malfunctioning electronics box assembly, complete with wiring harness.

CORRECTIVE ACTION

If the problem persists, replace the electronics box assembly, complete with wiring harness IAW WP 0048 00.

END OF WORK PACKAGE

**OPERATOR'S AND UNIT MAINTENANCE
SPACE HEATER, CONVECTIVE, 60K BTU
NSN 4520-01-520-6477
TROUBLESHOOTING PROCEDURES - FAULT CODE 8**

INITIAL SETUP**Tools**

None required

Personnel Required

One

Materials/Parts

None required

Equipment Condition

Heater set-up and ready to operate IAW WP 0005 00 and WP 0006 00 for tests or inspections.

Heater shut down, all advisory lights off, fans stopped and heater cool before attempting corrective action(s)

GENERAL

WARNING

During operation, some metal components of the heater assembly, such as the louver on the outlet duct, the upper and lower heater housing assemblies, combustion exhaust pipe, etc., become very hot. Contact with bare skin can cause severe burn injuries.

Do not attempt service procedures on a burner that has recently been in operation. Switch heater ON/OFF control to the OFF position, wait until the green HEATER ON/ON-HOLD light is OFF, indicating the end of operation, post purge, and cool down cycle completion before performing these procedures to avoid the possibility of serious burns or damaging the heater.

NOTE

When troubleshooting, wait for the heater to display a fault code and shut down. Count the number of times the system fault light flashes as well as the number of audible tones heard. Record the number of times the system fault advisory light flashes and refer to the troubleshooting instructions later in this section for that specific fault code.

The troubleshooting table that follows lists common malfunctions that you may encounter with your equipment. Perform the tests, inspections, and corrective actions in the order they appear in the table. Refer to the malfunction symptom index for a listing of all the problems that may be encountered and proceed to the troubleshooting procedure indicated in the index.

This table cannot list all the malfunctions that may occur, all the tests and inspections needed to find the fault, or all the corrective actions needed to correct the fault. If the equipment malfunction is not listed or actions listed do not correct the fault, notify your supervisor and they will refer the equipment to unit maintenance.

TROUBLESHOOTING PROCEDURE

FAULT CODE 8 – TIP-OVER

SYMPTOM

Heater inoperative, the system fault light repeatedly flashes eight times, and repeatedly sounds eight audible warning tones.

MALFUNCTION

The heater has been tipped more than 15 degrees in any direction.

CORRECTIVE ACTION

If the heater has been placed on snow, see if the snow may have melted, causing the condition. Shim the heater with dunnage to correct the condition. If necessary, move the heater to an area that slopes less than 2.6 feet in a 10-foot span.

END OF WORK PACKAGE

**OPERATOR'S AND UNIT MAINTENANCE
SPACE HEATER, CONVECTIVE, 60K BTU
NSN 4520-01-520-6477
TROUBLESHOOTING PROCEDURES - FAULT CODE 9**

INITIAL SETUP

Tools

Tool Kit, General Mechanic's (Item 1, WP 0067 00)

Personnel Required

One

Materials/Parts

Baled Rag, General (Item 3, WP 0092 00)

Mat, Petroleum Absorbent (Item 11, WP 0092 00)

Equipment Condition

Heater set-up and ready to operate IAW WP 0005 00 and WP 0006 00 for tests or inspections.

Heater shut down, all advisory lights off, fans stopped and heater cool before attempting corrective action(s)

GENERAL



WARNING

During operation, some metal components of the heater assembly, such as the louver on the outlet duct, the upper and lower heater housing assemblies, combustion exhaust pipe, etc., become very hot. Contact with bare skin can cause severe burn injuries.

Do not attempt service procedures on a burner that has recently been in operation. Switch heater ON/OFF control to the OFF position, wait until the green HEATER ON/ON-HOLD light is OFF, indicating the end of operation, post purge, and cool down cycle completion before performing these procedures to avoid the possibility of serious burns or damaging the heater.

NOTE

When troubleshooting, wait for the heater to display a fault code and shut down. Count the number of times the system fault light flashes as well as the number of audible tones heard. Record the number of times the system fault advisory light flashes and refer to the troubleshooting instructions later in this section for that specific fault code.

The troubleshooting table that follows lists common malfunctions that you may encounter with your equipment. Perform the tests, inspections, and corrective actions in the order they appear in the table. Refer to the malfunction symptom index for a listing of all the problems that may be encountered and proceed to the troubleshooting procedure indicated in the index.

This table cannot list all the malfunctions that may occur, all the tests and inspections needed to find the fault, or all the corrective actions needed to correct the fault. If the equipment malfunction is not listed or actions listed do not correct the fault, notify your supervisor and they will refer the equipment to unit maintenance.

TROUBLESHOOTING PROCEDURE**FAULT CODE 9 – FIN TEMP SENSOR****SYMPTOM**

Heater inoperative, the system fault light repeatedly flashes nine times, and repeatedly sounds nine audible warning tones.

MALFUNCTION

The fin temperature sensor has been disconnected.

CORRECTIVE ACTION

Remove the upper housing assembly and verify that the sensor connection is secure.

MALFUNCTION

The fin temperature sensor is open or shorted.

CORRECTIVE ACTION

Test the fin temperature sensor IAW WP 0061 00. Replace if necessary.

END OF WORK PACKAGE

**OPERATOR'S AND UNIT MAINTENANCE
SPACE HEATER, CONVECTIVE, 60K BTU
NSN 4520-01-520-6477
TROUBLESHOOTING PROCEDURES - FAULT CODE 10**

INITIAL SETUP**Tools**

None required

Personnel Required

One

Materials/Parts

None required

Equipment Condition

Heater set-up and ready to operate IAW WP 0005 00 and WP 0006 00 for tests or inspections.

Heater shut down, all advisory lights off, fans stopped and heater cool before attempting corrective action(s)

GENERAL

WARNING

During operation, some metal components of the heater assembly, such as the louver on the outlet duct, the upper and lower heater housing assemblies, combustion exhaust pipe, etc., become very hot. Contact with bare skin can cause severe burn injuries.

Do not attempt service procedures on a burner that has recently been in operation. Switch heater ON/OFF control to the OFF position, wait until the green HEATER ON/ON-HOLD light is OFF, indicating the end of operation, post purge, and cool down cycle completion before performing these procedures to avoid the possibility of serious burns or damaging the heater.

NOTE

When troubleshooting, wait for the heater to display a fault code and shut down. Count the number of times the system fault light flashes as well as the number of audible tones heard. Record the number of times the system fault advisory light flashes and refer to the troubleshooting instructions later in this section for that specific fault code.

The troubleshooting table that follows lists common malfunctions that you may encounter with your equipment. Perform the tests, inspections, and corrective actions in the order they appear in the table. Refer to the malfunction symptom index for a listing of all the problems that may be encountered and proceed to the troubleshooting procedure indicated in the index.

This table cannot list all the malfunctions that may occur, all the tests and inspections needed to find the fault, or all the corrective actions needed to correct the fault. If the equipment malfunction is not listed or actions listed do not correct the fault, notify your supervisor and they will refer the equipment to unit maintenance.

TROUBLESHOOTING PROCEDURE

FAULT CODE 10 – TENT OVER TEMPERATURE

SYMPTOM

Heater inoperative, the system fault light repeatedly flashes ten times, and repeatedly sounds ten audible warning tones.

MALFUNCTION

The in-tent controller temperature sensor detects a temperature in excess 90 degrees F (32.2 degrees C).

CORRECTIVE ACTION

Open the door and cool the interior of the tent. If problem persists after cooling down interior of the tent, disconnect the air supply inlet duct from the tent duct tunnel and allow the heater to draw cooler outside air as described in WP 0007 00, Operation in Moderate Climates.

Check the placement of the in-tent controller. If the in-tent controller is too close to the heated air duct opening, move the in-tent controller to a cooler location within the tent.

MALFUNCTION

The in-tent controller is defective.

CORRECTIVE ACTION

Test the in-tent controller IAW WP 0041 00. Replace a malfunctioning in-tent controller.

END OF WORK PACKAGE

**OPERATOR'S AND UNIT MAINTENANCE
SPACE HEATER, CONVECTIVE, 60K BTU
NSN 4520-01-520-6477
TROUBLESHOOTING PROCEDURES - FAULT CODE 11**

INITIAL SETUP

Tools

Tool Kit, General Mechanic's (Item 1, WP 0067 00)
 Battery Charging Adapter (Item 3, WP 0067 00)
 Commercial 12V DC Battery Charger (Item 4, WP 0067 00)
 NATO Charging System (Item 5, WP 0067 00)

Personnel Required

One

Materials/Parts

Baled Rag, General (Item 3, WP 0092 00)
 Mat, Petroleum Absorbent (Item 11, WP 0092 00)

Equipment Condition

Heater set-up and ready to operate IAW WP 0005 00 and WP 0006 00 for tests or inspections.

Heater shut down, all advisory lights off, fans stopped and heater cool before attempting corrective action(s)

GENERAL



WARNING

During operation, some metal components of the heater assembly, such as the louver on the outlet duct, the upper and lower heater housing assemblies, combustion exhaust pipe, etc., become very hot. Contact with bare skin can cause severe burn injuries.

Do not attempt service procedures on a burner that has recently been in operation. Switch heater ON/OFF control to the OFF position, wait until the green HEATER ON/ON-HOLD light is OFF, indicating the end of operation, post purge, and cool down cycle completion before performing these procedures to avoid the possibility of serious burns or damaging the heater.

NOTE

When troubleshooting, wait for the heater to display a fault code and shut down. Count the number of times the system fault light flashes as well as the number of audible tones heard. Record the number of times the system fault advisory light flashes and refer to the troubleshooting instructions later in this section for that specific fault code.

The troubleshooting table that follows lists common malfunctions that you may encounter with your equipment. Perform the tests, inspections, and corrective actions in the order they appear in the table. Refer to the malfunction symptom index for a listing of all the problems that may be encountered and proceed to the troubleshooting procedure indicated in the index.

This table cannot list all the malfunctions that may occur, all the tests and inspections needed to find the fault, or all the corrective actions needed to correct the fault. If the equipment malfunction is not listed or actions listed do not correct the fault, notify your supervisor and they will refer the equipment to unit maintenance.

TROUBLESHOOTING PROCEDURE

FAULT CODE 11 – LOW SYSTEM VOLTAGE

SYMPTOM

Heater inoperative, the system fault light repeatedly flashes eleven times, and repeatedly sounds eleven audible warning tones.

MALFUNCTION

If the battery has less than 10 volts when the heater is switched on, the voltage at the microprocessor drops below what is required to process information. This may occur after an excessive number of start attempts without a recharge cycle.

CORRECTIVE ACTION

Fully charge the battery using the NATO Charging System IAW WP 0006 00 or with a battery charger and the battery-charging adapter IAW WP 0043 00.

MALFUNCTION

Battery has exceeded its service life, and will not take a charge.

CORRECTIVE ACTION

Test the battery IAW WP 0043 00. Replace if necessary.

END OF WORK PACKAGE

**OPERATOR'S AND UNIT MAINTENANCE
SPACE HEATER, CONVECTIVE, 60K BTU
NSN 4520-01-520-6477
TROUBLESHOOTING PROCEDURES - FAULT CODE 12**

INITIAL SETUP**Tools**

Tool Kit, General Mechanic's (Item 1, WP 0067 00)

Personnel Required

One

Materials/Parts

Baled Rag, General (Item 3, WP 0092 00)

Mat, Petroleum Absorbent (Item 11, WP 0092 00)

Equipment Condition

Heater set-up and ready to operate IAW WP 0005 00 and WP 0006 00 for tests or inspections.

Heater shut down, all advisory lights off, fans stopped and heater cool before attempting corrective action(s)

GENERAL

WARNING

During operation, some metal components of the heater assembly, such as the louver on the outlet duct, the upper and lower heater housing assemblies, combustion exhaust pipe, etc., become very hot. Contact with bare skin can cause severe burn injuries.

Do not attempt service procedures on a burner that has recently been in operation. Switch heater ON/OFF control to the OFF position, wait until the green HEATER ON/ON-HOLD light is OFF, indicating the end of operation, post purge, and cool down cycle completion before performing these procedures to avoid the possibility of serious burns or damaging the heater.

NOTE

When troubleshooting, wait for the heater to display a fault code and shut down. Count the number of times the system fault light flashes as well as the number of audible tones heard. Record the number of times the system fault advisory light flashes and refer to the troubleshooting instructions later in this section for that specific fault code.

The troubleshooting table that follows lists common malfunctions that you may encounter with your equipment. Perform the tests, inspections, and corrective actions in the order they appear in the table. Refer to the malfunction symptom index for a listing of all the problems that may be encountered and proceed to the troubleshooting procedure indicated in the index.

This table cannot list all the malfunctions that may occur, all the tests and inspections needed to find the fault, or all the corrective actions needed to correct the fault. If the equipment malfunction is not listed or actions listed do not correct the fault, notify your supervisor and they will refer the equipment to unit maintenance.

TROUBLESHOOTING PROCEDURE**FAULT CODE 12 – INLET AIR OVER TEMPERATURE****SYMPTOM**

Heater inoperative, the system fault light repeatedly flashes twelve times, and repeatedly sounds twelve audible warning tones.

MALFUNCTION

The tent temperature is in excess 90 degrees F (32.2 degrees C).

CORRECTIVE ACTION

Open the door and cool the interior of the tent. If problem persists after cooling down interior of the tent, disconnect the air supply inlet duct from the tent duct tunnel and allow the heater to draw cooler outside air as described in WP 0007 00, Operation in Moderate Climates.

MALFUNCTION

The inlet air temperature sensor has been disconnected, or the wiring has been cut or damaged.

CORRECTIVE ACTION

Ensure the inlet air temperature sensor connector is connected securely. If wire problems are identified, refer to WP 0040 00 for instructions on repairing wires.

MALFUNCTION

The inlet air temperature sensor is malfunctioning.

CORRECTIVE ACTION

If the above corrective actions fail to remedy the fault, replace the inlet air temperature sensor IAW WP 0055 00.

END OF WORK PACKAGE

**OPERATOR'S AND UNIT MAINTENANCE
SPACE HEATER, CONVECTIVE, 60K BTU
NSN 4520-01-520-6477
TROUBLESHOOTING PROCEDURES - FAULT CODE 14**

INITIAL SETUP

Tools

Tool Kit, General Mechanic's (Item 1, WP 0067 00)

Personnel Required

One

Materials/Parts

Baled Rag, General (Item 3, WP 0092 00)
Gasket (Item 6, WP 0092 00)
Mat, Petroleum Absorbent (Item 11, WP 0092 00)
Screen (Item 12, WP 0092 00)

Equipment Condition

Heater set-up and ready to operate IAW WP 0005 00 and WP 0006 00 for tests or inspections.

Heater shut down, all advisory lights off, fans stopped and heater cool before attempting corrective action(s)

GENERAL



WARNING

During operation, some metal components of the heater assembly, such as the louver on the outlet duct, the upper and lower heater housing assemblies, combustion exhaust pipe, etc., become very hot. Contact with bare skin can cause severe burn injuries.

Do not attempt service procedures on a burner that has recently been in operation. Switch heater ON/OFF control to the OFF position, wait until the green HEATER ON/ON-HOLD light is OFF, indicating the end of operation, post purge, and cool down cycle completion before performing these procedures to avoid the possibility of serious burns or damaging the heater.

NOTE

When troubleshooting, wait for the heater to display a fault code and shut down. Count the number of times the system fault light flashes as well as the number of audible tones heard. Record the number of times the system fault advisory light flashes and refer to the troubleshooting instructions later in this section for that specific fault code.

The troubleshooting table that follows lists common malfunctions that you may encounter with your equipment. Perform the tests, inspections, and corrective actions in the order they appear in the table. Refer to the malfunction symptom index for a listing of all the problems that may be encountered and proceed to the troubleshooting procedure indicated in the index.

This table cannot list all the malfunctions that may occur, all the tests and inspections needed to find the fault, or all the corrective actions needed to correct the fault. If the equipment malfunction is not listed or actions listed do not correct the fault, notify your supervisor and they will refer the equipment to unit maintenance.

TROUBLESHOOTING PROCEDURE

FAULT CODE 14 – FUEL SOLENOID

SYMPTOM

Heater inoperative, the system fault light repeatedly flashes fourteen times, and repeatedly sounds fourteen audible warning tones.

MALFUNCTION

The fuel solenoid connector has dislodged or is damaged.

CORRECTIVE ACTION

Ensure the fuel solenoid modular connector is connected securely. If wire problems are identified, refer to WP 0040 00 for instructions on repairing wires.

MALFUNCTION

The fuel solenoid is malfunctioning.

CORRECTIVE ACTION

Test the fuel solenoid per the instructions in WP 0046 00. Replace an open or shorted fuel solenoid.

END OF WORK PACKAGE

**OPERATOR'S AND UNIT MAINTENANCE
SPACE HEATER, CONVECTIVE, 60K BTU
NSN 4520-01-520-6477
TROUBLESHOOTING PROCEDURES - FAULT CODE 15**

INITIAL SETUP**Tools**

Tool Kit, General Mechanic's (Item 1, WP 0067 00)

Personnel Required

One

Materials/Parts

Baled Rag, General (Item 3, WP 0092 00)

Mat, Petroleum Absorbent (Item 11, WP 0092 00)

Equipment Condition

Heater set-up and ready to operate IAW WP 0005 00 and WP 0006 00 for tests or inspections.

Heater shut down, all advisory lights off, fans stopped and heater cool before attempting corrective action(s)

GENERAL

WARNING

During operation, some metal components of the heater assembly, such as the louver on the outlet duct, the upper and lower heater housing assemblies, combustion exhaust pipe, etc., become very hot. Contact with bare skin can cause severe burn injuries.

Do not attempt service procedures on a burner that has recently been in operation. Switch heater ON/OFF control to the OFF position, wait until the green HEATER ON/ON-HOLD light is OFF, indicating the end of operation, post purge, and cool down cycle completion before performing these procedures to avoid the possibility of serious burns or damaging the heater.

NOTE

When troubleshooting, wait for the heater to display a fault code and shut down. Count the number of times the system fault light flashes as well as the number of audible tones heard. Record the number of times the system fault advisory light flashes and refer to the troubleshooting instructions later in this section for that specific fault code.

The troubleshooting table that follows lists common malfunctions that you may encounter with your equipment. Perform the tests, inspections, and corrective actions in the order they appear in the table. Refer to the malfunction symptom index for a listing of all the problems that may be encountered and proceed to the troubleshooting procedure indicated in the index.

This table cannot list all the malfunctions that may occur, all the tests and inspections needed to find the fault, or all the corrective actions needed to correct the fault. If the equipment malfunction is not listed or actions listed do not correct the fault, notify your supervisor and they will refer the equipment to unit maintenance.

TROUBLESHOOTING PROCEDURE**FAULT CODE 15 – FUEL PUMP/MANUAL THERMOSTAT RESET****SYMPTOM**

Heater inoperative, the system fault light repeatedly flashes fifteen times, and repeatedly sounds fifteen audible warning tones.

MALFUNCTION

The manual thermostat reset has been activated by an overheated heat exchanger, opening the circuit to the fuel pump. Test the manual thermostat reset IAW WP 005700, and replace if necessary.

CORRECTIVE ACTION

Reset the Manual Thermostat Reset Switch by depressing the button. This will close the circuit to the fuel pump.

MALFUNCTION

The heater ducts are obstructed or crushed by the tent wall, causing the heat exchanger to overheat.

CORRECTIVE ACTION

Remove any obstructions from the heater inlet or outlet duct. If necessary, install a Tent Wall Modification Kit. Refer to instructions in WP 0005 00.

MALFUNCTION

The fuel pump modular connector has dislodged or is damaged.

CORRECTIVE ACTION

Ensure the fuel pump modular connector is connected securely. If wire problems are identified, refer to WP 0040 00 for instructions on repairing wires.

MALFUNCTION

The fuel pump is malfunctioning.

CORRECTIVE ACTION

Test the fuel pump IAW WP 0056 00. Replace an open or shorted fuel pump.

END OF WORK PACKAGE

**OPERATOR'S AND UNIT MAINTENANCE
SPACE HEATER, CONVECTIVE, 60K BTU
NSN 4520-01-520-6477
TROUBLESHOOTING PROCEDURES - FAULT CODE 16**

INITIAL SETUP**Tools**

Tool Kit, General Mechanic's (Item 1, WP 0067 00)

Personnel Required

One

Materials/Parts

Baled Rag, General (Item 3, WP 0092 00)

Mat, Petroleum Absorbent (Item 11, WP 0092 00)

Equipment Condition

Heater set-up and ready to operate IAW WP 0005 00 and WP 0006 00 for tests or inspections.

Heater shut down, all advisory lights off, fans stopped and heater cool before attempting corrective action(s)

GENERAL

WARNING

During operation, some metal components of the heater assembly, such as the louver on the outlet duct, the upper and lower heater housing assemblies, combustion exhaust pipe, etc., become very hot. Contact with bare skin can cause severe burn injuries.

Do not attempt service procedures on a burner that has recently been in operation. Switch heater ON/OFF control to the OFF position, wait until the green HEATER ON/ON-HOLD light is OFF, indicating the end of operation, post purge, and cool down cycle completion before performing these procedures to avoid the possibility of serious burns or damaging the heater.

NOTE

When troubleshooting, wait for the heater to display a fault code and shut down. Count the number of times the system fault light flashes as well as the number of audible tones heard. Record the number of times the system fault advisory light flashes and refer to the troubleshooting instructions later in this section for that specific fault code.

The troubleshooting table that follows lists common malfunctions that you may encounter with your equipment. Perform the tests, inspections, and corrective actions in the order they appear in the table. Refer to the malfunction symptom index for a listing of all the problems that may be encountered and proceed to the troubleshooting procedure indicated in the index.

This table cannot list all the malfunctions that may occur, all the tests and inspections needed to find the fault, or all the corrective actions needed to correct the fault. If the equipment malfunction is not listed or actions listed do not correct the fault, notify your supervisor and they will refer the equipment to unit maintenance.

TROUBLESHOOTING PROCEDURE

FAULT CODE 16 – VENT MOTOR

SYMPTOM

Heater inoperative, the system fault light repeatedly flashes sixteen times, and repeatedly sounds sixteen audible warning tones.

MALFUNCTION

Snow or ice buildup on the vent motor.

CORRECTIVE ACTION

Remove any snow or ice as necessary. If ice buildup is present place the heater in a heated area for sufficient time to melt the ice. To reduce the incidence of snow or ice on the vent fan, always connect the duct to the heater even if it is not connected to the tent duct tunnels.

MALFUNCTION

Loose or broken wires on the vent fan terminal block.

CORRECTIVE ACTION

Ensure the vent fan terminal block wires are connected securely. If wire problems are identified, refer to WP 0040 00 for instructions on repairing wires.

MALFUNCTION

Vent motor malfunction.

CORRECTIVE ACTION

Test the vent motor IAW WP 0054 00. Replace an open or shorted vent motor.

MALFUNCTION

Electronics box assembly complete with wiring harness is defective.

CORRECTIVE ACTION

Refer to WP 0048 00 to inspect, repair, or replace.

END OF WORK PACKAGE

**OPERATOR'S AND UNIT MAINTENANCE
SPACE HEATER, CONVECTIVE, 60K BTU
NSN 4520-01-520-6477
TROUBLESHOOTING PROCEDURES - FAULT CODE 17**

INITIAL SETUP**Tools**

Tool Kit, General Mechanic's (Item 1, WP 0067 00)

Personnel Required

One

Materials/Parts

Baled Rag, General (Item 3, WP 0092 00)

Mat, Petroleum Absorbent (Item 11, WP 0092 00)

Equipment Condition

Heater set-up and ready to operate IAW WP 0005 00 and WP 0006 00 for tests or inspections.

Heater shut down, all advisory lights off, fans stopped and heater cool before attempting corrective action(s)

GENERAL

WARNING

During operation, some metal components of the heater assembly, such as the louver on the outlet duct, the upper and lower heater housing assemblies, combustion exhaust pipe, etc., become very hot. Contact with bare skin can cause severe burn injuries.

Do not attempt service procedures on a burner that has recently been in operation. Switch heater ON/OFF control to the OFF position, wait until the green HEATER ON/ON-HOLD light is OFF, indicating the end of operation, post purge, and cool down cycle completion before performing these procedures to avoid the possibility of serious burns or damaging the heater.

NOTE

When troubleshooting, wait for the heater to display a fault code and shut down. Count the number of times the system fault light flashes as well as the number of audible tones heard. Record the number of times the system fault advisory light flashes and refer to the troubleshooting instructions later in this section for that specific fault code.

The troubleshooting table that follows lists common malfunctions that you may encounter with your equipment. Perform the tests, inspections, and corrective actions in the order they appear in the table. Refer to the malfunction symptom index for a listing of all the problems that may be encountered and proceed to the troubleshooting procedure indicated in the index.

This table cannot list all the malfunctions that may occur, all the tests and inspections needed to find the fault, or all the corrective actions needed to correct the fault. If the equipment malfunction is not listed or actions listed do not correct the fault, notify your supervisor and they will refer the equipment to unit maintenance.

TROUBLESHOOTING PROCEDURE

FAULT CODE 17 – INLET AIR TEMPERATURE SENSOR

SYMPTOM

Heater inoperative, the system fault light repeatedly flashes seventeen times, and repeatedly sounds seventeen audible warning tones.

MALFUNCTION

Inlet air temperature sensor disconnected.

CORRECTIVE ACTION

Ensure the inlet air temperature sensor is connected securely. If wire problems are identified, refer to WP 0040 00 for instructions on repairing wires.

MALFUNCTION

Inlet air temperature sensor malfunctioning.

CORRECTIVE ACTION

Replace the inlet air temperature sensor IAW WP 0055 00.

END OF WORK PACKAGE

**OPERATOR'S AND UNIT MAINTENANCE
SPACE HEATER, CONVECTIVE, 60K BTU
NSN 4520-01-520-6477
TROUBLESHOOTING PROCEDURES - FAULT CODE 18**

INITIAL SETUP

Tools

Tool Kit, General Mechanic's (Item 1, WP 0067 00)

Personnel Required

One

Materials/Parts

Baled Rag, General (Item 3, WP 0092 00)
Mat, Petroleum Absorbent (Item 11, WP 0092 00)

Equipment Condition

Heater set-up and ready to operate IAW WP 0005 00 and WP 0006 00 for tests or inspections.

Heater shut down, all advisory lights off, fans stopped and heater cool before attempting corrective action(s)

GENERAL



WARNING

During operation, some metal components of the heater assembly, such as the louver on the outlet duct, the upper and lower heater housing assemblies, combustion exhaust pipe, etc., become very hot. Contact with bare skin can cause severe burn injuries.

Do not attempt service procedures on a burner that has recently been in operation. Switch heater ON/OFF control to the OFF position, wait until the green HEATER ON/ON-HOLD light is OFF, indicating the end of operation, post purge, and cool down cycle completion before performing these procedures to avoid the possibility of serious burns or damaging the heater.

NOTE

When troubleshooting, wait for the heater to display a fault code and shut down. Count the number of times the system fault light flashes as well as the number of audible tones heard. Record the number of times the system fault advisory light flashes and refer to the troubleshooting instructions later in this section for that specific fault code.

The troubleshooting table that follows lists common malfunctions that you may encounter with your equipment. Perform the tests, inspections, and corrective actions in the order they appear in the table. Refer to the malfunction symptom index for a listing of all the problems that may be encountered and proceed to the troubleshooting procedure indicated in the index.

This table cannot list all the malfunctions that may occur, all the tests and inspections needed to find the fault, or all the corrective actions needed to correct the fault. If the equipment malfunction is not listed or actions listed do not correct the fault, notify your supervisor and they will refer the equipment to unit maintenance.

TROUBLESHOOTING PROCEDURE**FAULT CODE 18 – BATTERY TEMPERATURE SENSOR****SYMPTOM**

Heater inoperative, the system fault light repeatedly flashes eighteen times, and repeatedly sounds eighteen audible warning tones.

MALFUNCTION

Loose battery connection.

CORRECTIVE ACTION

Push the battery pack connector in securely and ensure locking tabs have engaged completely. Refer to WP 0005 00 if necessary.

MALFUNCTION

Damaged battery connector or wiring.

CORRECTIVE ACTION

If the connector or wiring leading from the battery pack connector to the battery pack is damaged, replace the battery. Refer to WP 0043 00 if necessary.

MALFUNCTION

Battery sensor malfunction.

CORRECTIVE ACTION

Replace the battery with a known good battery, or a new battery. Refer to WP 0043 00 if necessary.

MALFUNCTION

Damaged harness connectors or wiring.

CORRECTIVE ACTION

If the connector or wiring on the inside of the heater from the battery connector to the main control board is damaged, replace the electronics box assembly, complete with wire harness IAW WP 0048 00.

END OF WORK PACKAGE

**OPERATOR'S AND UNIT MAINTENANCE
SPACE HEATER, CONVECTIVE, 60K BTU
NSN 4520-01-520-6477
TROUBLESHOOTING PROCEDURES - HEATER FAILS TO START**

INITIAL SETUP**Tools**

Tool Kit, General Mechanic's (Item 1, WP 0067 00)
 Battery Charging Adapter (Item 3, WP 0067 00)
 Commercial 12V DC Battery Charger (Item 4, WP 0067
 00)
 NATO Charging System (Item 5, WP 0067 00)

Personnel Required

One

Materials/Parts

Baled Rag, General (Item 3, WP 0092 00)
 Kit, Burner (Item 8, WP 0092 00)
 Mat, Petroleum Absorbent (Item 11, WP 0092 00)

Equipment Condition

Heater set-up and ready to operate
 IAW WP 0005 00 and WP 0006 00 for
 tests or inspections.

Heater shut down, all advisory lights
 off, fans stopped and heater cool
 before attempting corrective action(s)

GENERAL

WARNING

During operation, some metal components of the heater assembly, such as the louver on the outlet duct, the upper and lower heater housing assemblies, combustion exhaust pipe, etc., become very hot. Contact with bare skin can cause severe burn injuries.

Do not attempt service procedures on a burner that has recently been in operation. Switch heater ON/OFF control to the OFF position, wait until the green HEATER ON/ON-HOLD light is OFF, indicating the end of operation, post purge, and cool down cycle completion before performing these procedures to avoid the possibility of serious burns or damaging the heater.

NOTE

When troubleshooting, wait for the heater to display a fault code and shut down. Count the number of times the system fault light flashes as well as the number of audible tones heard. Record the number of times the system fault advisory light flashes and refer to the troubleshooting instructions later in this section for that specific fault code.

The troubleshooting table that follows lists common malfunctions that you may encounter with your equipment. Perform the tests, inspections, and corrective actions in the order they appear in the table. Refer to the malfunction symptom index for a listing of all the problems that may be encountered and proceed to the troubleshooting procedure indicated in the index.

This table cannot list all the malfunctions that may occur, all the tests and inspections needed to find the fault, or all the corrective actions needed to correct the fault. If the equipment malfunction is not listed or actions listed do not correct the fault, notify your supervisor and they will refer the equipment to unit maintenance.

TROUBLESHOOTING PROCEDURE**HEATER FAILS TO START****SYMPTOM**

Heater has been set up IAW WP 0005 00 and attempts have been made to operate the heater IAW WP 0006 00.

MALFUNCTION

Heater ON/OFF switch on the in-tent controller is in the OFF position.

CORRECTIVE ACTION

Place the switch in the ON position and restart.

MALFUNCTION

The in-tent controller cable has been incorrectly connected.

CORRECTIVE ACTION

Securely connect the in-tent controller cable to the control connector located on the lower housing.

MALFUNCTION

Battery disconnected.

CORRECTIVE ACTION

Push the battery pack connector in securely and ensure locking tabs have engaged completely. Refer to WP 0005 00 if necessary.

MALFUNCTION

Open fuses.

CORRECTIVE ACTION

Remove fuses from battery pack. Visually inspect the element inside the fuse to ensure both fuses are in good condition. If one or more fuse is bad or if in doubt, replace bad fuse(s) with spare fuse(s) located behind duct adapter at heater inlet assembly. Test fuses IAW WP 0043 00.

MALFUNCTION

Battery requires charge.

CORRECTIVE ACTION

Charge the battery with either the NATO charging system IAW WP 0006 00, or with a battery charger and charging adapter IAW WP 0043 00.

MALFUNCTION

Battery damaged or malfunctioning.

CORRECTIVE ACTION

Test the battery, and replace if necessary IAW WP 0043 00.

MALFUNCTION

In-tent controller is malfunctioning.

CORRECTIVE ACTION

Inspect and test the in-tent controller IAW WP 0041 00. Replace a malfunctioning in-tent controller.

MALFUNCTION

The in-tent controller cable is open or shorted.

CORRECTIVE ACTION

Test the in-tent controller cable IAW WP 0042 00. Replace an open or shorted cable.

MALFUNCTION

Burner assembly has carbon build-up and requires cleaning.

CORRECTIVE ACTION

Refer to WP 0036 00 to inspect for carbon build-up and perform the cleaning procedure.

MALFUNCTION

Burner vaporizer pad reached its maximum life and requires replacement.

CORRECTIVE ACTION

Refer to WP 0036 00 for instructions on replacing the burner vaporizer pad.

MALFUNCTION

Burner is damaged or worn.

CORRECTIVE ACTION

Inspect burner IAW WP 0060 00, and replace if damaged or worn.

END OF WORK PACKAGE

**OPERATOR'S AND UNIT MAINTENANCE
SPACE HEATER, CONVECTIVE, 60K BTU
NSN 4520-01-520-6477
TROUBLESHOOTING PROCEDURES -
HEATER PRODUCES A RUMBLING NOISE WHEN OPERATING**

INITIAL SETUP**Tools**

Tool Kit, General Mechanic's (Item 1, WP 0067 00)

Personnel Required

One

Materials/Parts

Baled Rag, General (Item 3, WP 0092 00)

Kit, Burner (Item 8, WP 0092 00)

Mat, Petroleum Absorbent (Item 11, WP 0092 00)

Equipment Condition

Heater set-up and ready to operate IAW WP 0005 00 and WP 0006 00 for tests or inspections.

Heater shut down, all advisory lights off, fans stopped and heater cool before attempting corrective action(s)

GENERAL

WARNING

During operation, some metal components of the heater assembly, such as the louver on the outlet duct, the upper and lower heater housing assemblies, combustion exhaust pipe, etc., become very hot. Contact with bare skin can cause severe burn injuries.

Do not attempt service procedures on a burner that has recently been in operation. Switch heater ON/OFF control to the OFF position, wait until the green HEATER ON/ON-HOLD light is OFF, indicating the end of operation, post purge, and cool down cycle completion before performing these procedures to avoid the possibility of serious burns or damaging the heater.

NOTE

When troubleshooting, wait for the heater to display a fault code and shut down. Count the number of times the system fault light flashes as well as the number of audible tones heard. Record the number of times the system fault advisory light flashes and refer to the troubleshooting instructions later in this section for that specific fault code.

The troubleshooting table that follows lists common malfunctions that you may encounter with your equipment. Perform the tests, inspections, and corrective actions in the order they appear in the table. Refer to the malfunction symptom index for a listing of all the problems that may be encountered and proceed to the troubleshooting procedure indicated in the index.

This table cannot list all the malfunctions that may occur, all the tests and inspections needed to find the fault, or all the corrective actions needed to correct the fault. If the equipment malfunction is not listed or actions listed do not correct the fault, notify your supervisor and they will refer the equipment to unit maintenance.

TROUBLESHOOTING PROCEDURE

HEATER PRODUCES A RUMBLING NOISE WHEN OPERATING

SYMPTOM

Heater operates with loud rumbling noise.

MALFUNCTION

Burner assembly has carbon build-up and requires cleaning.

CORRECTIVE ACTION

Refer to WP 0036 00 to inspect for carbon build-up and perform the cleaning procedure.

END OF WORK PACKAGE

CHAPTER 4
MAINTENANCE INSTRUCTIONS
SPACE HEATER, CONVECTIVE 60K BTU (SHC-60K)

**OPERATOR'S AND UNIT MAINTENANCE
SPACE HEATER, CONVECTIVE 60K BTU (SHC-60K)
NSN 4520-01-520-6477
SERVICE UPON RECEIPT**

INITIAL SETUP**Tools**

None required

Personnel Required

One

Materials/Parts

None required

Equipment Condition

Heater unpacked from shipping materials

GENERAL

WARNING

During operation, some metal components of the heater assembly, such as the louver on the outlet duct, the upper and lower heater housing assemblies, combustion exhaust pipe, etc., become very hot. Contact with bare skin can cause severe burn injuries.

Do not attempt service procedures on a burner that has recently been in operation. Switch heater ON/OFF control to the OFF position, wait until the green HEATER ON/ON-HOLD light is OFF, indicating the end of operation, post purge, and cool down cycle completion before performing these procedures to avoid the possibility of serious burns or damaging the heater.

GENERAL

The heaters are shipped in standard-type corrugated cardboard boxes. All components to the heaters are stowed within accessory bags. The Unit Maintenance technician should inspect the equipment before it is used. Following is a list of functions which must be performed upon receipt of the SHC-60K:

Unpacking. Before operation, heaters must be unpacked and cleaned of packing material and other foreign debris, and serviced in accordance with PMCS Table 1, WP 0033 00.

Inspection. The equipment must be inspected for damage incurred during shipment. If the equipment has been damaged in shipment, report the damage on SF 364, Report of Discrepancy.

Packing list verification. Check the equipment against the packing list to see if the shipment is complete. Report all discrepancies in accordance with DA Pam 750-8.

Verification of equipment modifications. Check to see whether the equipment has been modified. No unauthorized modifications should be made to the SHC-60K.

Pre-operation services. Service damaged equipment, as necessary, using Unit Maintenance procedures in Chapter 4 to restore equipment to operable condition.

Break-in Period. The SHC-60K should be set up and operated for a break-in period of 1 to 2 hours in a well ventilated area so that any fumes generated by newly painted parts can flash off.

SITING**WARNING**

The heater cannot be placed any closer than two feet to the tent or any other combustible material. Failure to observe this precaution may result in fire, with serious injury or death to personnel.

NOTE

Testing indicated that the heater may interfere with other electronics equipment in its vicinity. If this occurs, move the electronic equipment away from the heater until interference is no longer a problem.

NOTE

Heater will not operate when tilt or grade is greater than 15 degrees, which is a 2.6 foot drop over a 10 foot span.

Refer to WP 0005 00 for additional information for siting of equipment.

SERVICE UPON RECEIPT OF MATERIAL

Inspect containers and packaging upon receipt for evidence of damage occurring in shipping. The heater package and its accessories were carefully inspected and securely packaged prior to shipment. If damage to the containers or packaging is found it is the shipper's responsibility.

Do not unpack a heater that is obviously damaged in shipment until the shipper is notified and has inspected the packaging. Notify your supervisor.

**WARNING**

Excessive weight hazard. The Space Heater, Convective 60K BTU (SHC-60K) weighs approximately **118 pounds (53.5 kg)** with accessories and transit bag. Four persons must carry the unit, lifting with legs, not back, to prevent injury. Failure to do so may result in serious back or other muscular skeletal injuries.

Remove heater package and accessories from shipping containers and packaging.

Inspect the heater package and accessories for completeness by comparing the contents against the description of the equipment found in WP 0090 00 in the Components of End Item (COEI) work package of this technical manual.

INSTALLATION INSTRUCTIONS

Refer to WP 0005 00 for equipment SHC 60K and Tent Wall Modification Kit (TWMK) installation instructions.

PRELIMINARY CHECKS AND ADJUSTMENTS OF EQUIPMENT**WARNING**

Fuels are toxic and flammable. Do not refuel near open flame or other ignition sources. Only refuel in a well-ventilated area. Wear eye/face protection, avoiding contact with skin and clothes, and don't breathe vapors. If contact with eyes or skin is made, immediately flush with clean water and get medical aid for eyes. If contact with clothing or skin is made, immediately remove contaminated clothing and clean skin with mild soap or cleanser and flush with clean water.

Always store fuel can in well-ventilated area as far away from open flames and other potential ignition sources as possible. Leaking or spilled fuels will create a fire danger-injuries/death and environmental damage. Fuel spills must be cleaned up in accordance with local requirements.

Carbon monoxide is a gas without color, smell, or taste, but can kill you. Breathing carbon monoxide may produce symptoms of headache, dizziness, loss of muscular control, a sleepy feeling, and unconsciousness or coma. Brain damage or death can result from heavy exposure. Carbon monoxide is present in the exhaust fumes of any fuel-burning heaters and internal combustion engines. Fatal concentrations of carbon monoxide will occur if the Space Heater, Convective 60K BTU (SHC-60K), or any fuel burning space heater, is operated in an enclosed area such as a tent or structure.

Precautions must be followed to ensure operator's safety when the Space Heater, Convective 60K BTU (SHC-60K) is in operation.

- DO NOT operate the SHC-60K in an enclosed area.
- Direct the SHC-60K exhaust outlet away from shelters or personnel.
- BE ALERT at all times during operating procedures for carbon monoxide poisoning. If symptoms are present, IMMEDIATELY evacuate personnel and seek medical attention.
- BE AWARE the field protection mask used for nuclear-biological-chemical attack WILL NOT protect you from carbon monoxide poisoning.

THE BEST DEFENSE AGAINST CARBON MONOXIDE POISONING IS GOOD VENTILATION.

Refer to Work Package 0005 00 for additional instructions for preliminary checks and adjustments of equipment.

END OF WORK PACKAGE

**OPERATOR'S AND UNIT MAINTENANCE
SPACE HEATER, CONVECTIVE 60K BTU (SHC-60K)
NSN 4520-01-520-6477
PREVENTIVE MAINTENANCE CHECKS AND SERVICES (PMCS), INTRODUCTION**

INTRODUCTION

Preventive Maintenance Checks and Services (PMCS) are performed to keep the Space Heater, Convective, 60K BTU in good operating condition and ready for its primary mission. The checks are used to find, correct, and report problems. PMCS is performed every day the Space Heater, Convective, 60 KBTU is in operation, and is done according to the PMCS table provided. Pay attention to **WARNING**, **CAUTION**, and **NOTE** statements. A **WARNING** indicates that someone could be hurt or killed. A **CAUTION** indicates that equipment could be damaged. A **NOTE** may make your maintenance or repair task easier.

Be sure to perform scheduled PMCS. Always perform PMCS in the same order so it becomes habit. With practice, you will quickly recognize problems with the equipment.

Use DA Form 2404, Equipment Inspection and Maintenance Worksheet, to record any discovered faults. Do not record faults that you fix!

PMCS PROCEDURES

Table 1 lists inspections and care required to keep your equipment in good operating condition. It is arranged so that you can perform before operation checks as you walk around the equipment.

EXPLANATION OF TABLE 1 COLUMNS

Item Number

Indicates the reference number. When completing DA Form 2404, Equipment Inspection and Maintenance Worksheet, include the item number for the item to check/service indicating a fault. Item numbers appear in the order you must perform the checks/services listed.

Intervals

Indicates when you must perform the procedure in the procedure column.

- before** - perform before equipment operation
- during** - perform during equipment operation
- after** - perform after equipment has been operated
- daily** - perform every day (24 hour period)
- weekly** - perform every week
- monthly** - perform each month
- hours** - perform at the noted hourly interval

Item to be Checked or Serviced

Indicates the item to be checked or serviced.

Procedures

Indicates the procedure you must perform on the item listed in Item to Check/Service column. You must perform the procedure at the time specified in the Interval column.

Equipment Not Ready/Available If:

Indicates faults which will prevent your equipment from performing its primary mission. If you perform procedures listed in Procedure column which show faults listed in this column, do not operate the equipment. Follow standard procedures for maintaining the equipment or reporting equipment failure. If you are not authorized to perform a task, notify unit maintenance.

Other Special Entries

Observe all special information and notes that appear in Table 1 of WP 0033 00.

When a check/service procedure is required for both weekly and before intervals, it is not necessary to perform the procedure twice if the equipment is operated during the weekly period.

COMMON CHECKS AND CLEANING**Cleaning**

Always keep the equipment clean. Remove dirt, sand, and debris from all circuit breakers and hose connections.

Bolts, Nuts, and Screws

Check them for obvious looseness, missing, bent, or broken condition on equipment. If you find a bolt, nut, or screw you think is loose, tighten it or report it to your supervisor.

Hoses

Look for wear, damage, and leaks. Ensure clamps are tight. Wet spots show leaks, but a stain around a fitting or connector can also mean a leak. If a leak comes from a loose fitting or coupling, tighten it. If something is broken or worn out, report it to your supervisor.

LEAKAGE DEFINITION FOR PERFORMING PMCS

It is necessary for you to know how fluid leakage affects the status of the equipment. The following are the types/classes of leakage an operator needs to know to be able to determine the status of the water system. Learn these leakage definitions and remember - when in doubt, notify your supervisor.

**WARNING**

Always store fuel cans in a well-ventilated area as far away from open flames and other potential ignition sources as possible. Leaking or spilled fuels will create a fire danger-injuries/death and environmental damage. Fuel spills must be cleaned up in accordance with local requirements.

CAUTION

Equipment operation is allowable with minor leakages (Class I or II). Of course, consideration must be given to fluid capacity in the system, when in doubt, notify your supervisor.

When operating with Class I or II leaks, continue to check fluid levels as required in your PMCS.

Class III leaks should be reported immediately to your supervisor.

Class I - Seepage of fluid (as indicated by wetness or discoloration) not great enough to form drops.

Class II - Leakage of fluid great enough to form drops but not enough to cause drops to drip from item being checked/inspected.

Class III - Leakage of fluid great enough to form drops that fall from items being checked/inspected.

END OF WORK PACKAGE

**OPERATOR'S MAINTENANCE
SPACE HEATER, CONVECTIVE 60K BTU (SHC-60K)
NSN 4520-01-520-6477
PREVENTIVE MAINTENANCE CHECKS AND SERVICES (PMCS)**

Table 1. Preventive Maintenance Checks and Services.

Item No.	Interval	Location Item to Check/Service	Procedures	Equipment Not Ready/Available If
1	Before	Air Supply and Return Ducts	<p>Check the air supply and return ducts (Figure 1, Items 1 and 2) for holes and tears in the fabric. Repair damaged ducts if possible, replace duct if damage cannot be repaired.</p> <p>Check outside surface of duct for any dirt or debris. Clean dirt and debris from exterior of duct with a clean dry rag.</p> <p>Ensure airflow direction tags are in place and legible.</p> <p>Check for and remove any obstructions inside of ducts.</p> <p>Inspect straps (Figure 1, Item 3) on ends of ducts for broken buckles, cuts, abrasions, or other damage that would prevent the ducts from having a tight seal to the duct adapter or debris grill.</p> <p>Inspect the debris grill (Figure 1, Item 4) on the end of both ducts and ensure that the grills are not broken or otherwise damaged.</p>	<p>There are holes, tears, or other damage that cannot be repaired and that would permit air to enter or escape through the side walls of the duct.</p> <p>Duct exterior dirty.</p> <p>Tags missing or illegible.</p> <p>There are obstructions within the duct that cannot be cleared.</p> <p>Straps on ducts are broken.</p> <p>Debris grill missing or broken.</p>



Figure 1. Preventive Maintenance Checks and Services - Air Supply and Return Ducts.

Table 1. Preventive Maintenance Checks and Services – Continued.

Item No.	Interval	Location Item to Check/ Service	Procedures	Equipment Not Ready/Available If:
2	Before	Gravity feed adapter (GFA)	<p>Check gravity feed adapter (Figure 2, Item 1) and fuel hose assembly (Figure 2, Item 2) for leaks.</p> <p>Inspect fitting (Figure 2, Item 3) on gravity feed adapter (Figure 2, Item 1) to ensure that it is not bent, dented, or damaged in any way that would prevent a good, leakproof, seal.</p> <p>Inspect rubber seal (Figure 2, Item 4) on underside of adapter and ensure that it has no cuts, tears or other damage.</p> <p>Inspect umbrella valve (Figure 2, Item 5) for nicks and cuts that may prevent it from sealing. If damage is seen or if GFA leaks, remove the umbrella valve (Figure 2, Item 5) from valve body (Figure 2, Item 6) by pinching in the center and gently pulling away from valve body. Inspect the valve body for signs of dirt or foreign matter that may plug the fuel passages or keep the umbrella valve from seating properly.</p> <p>A spare umbrella valve is located under a cap (Figure 2, Item 7) on the top of the GFA. To install the umbrella valve, gently push on the center until the umbrella valve snaps into place into the valve body.</p>	<p>Gravity feed adapter leaks.</p> <p>Quick disconnect fitting is damaged.</p> <p>Seal on underside of adapter is damaged or missing.</p> <p>Umbrella valve leaks or is plugged.</p>
3	Before	Y adapter	<p>Check the Y adapter (Figure 2, Item 8) for physical damage, corrosion, and cleanliness.</p> <p>Ensure the valves operate smoothly.</p>	<p>Y adapter damaged, corroded, or contaminated.</p> <p>Valves inoperable</p>
4	Before	Fuel Can	<p>Check fuel can (Figure 2, Item 9) and ensure that cap (Figure 2, Item 10) seals properly and that there are no cracks in the can that would permit a fuel leak.</p>	<p>Can is physically damaged or leaking.</p>
5	Before	Fuel Can Stand	<p>Check fuel can stand (Figure 2, Item 11) for bent leg (Figure 2, Item 12), damaged or missing fuel can stand support arms (Figure 2, Item 13). Check for frayed or broken strap (Figure 2, Item 14). Check clip (Figure 2, Item 15) to make sure it is not broken or missing. If fuel can stand is damaged and cannot support the weight of a full fuel can, replace stand.</p>	<p>Stand cannot securely support full fuel can.</p>

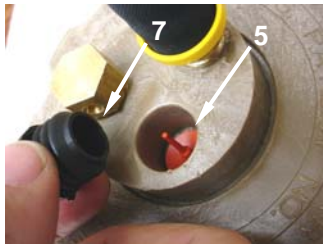
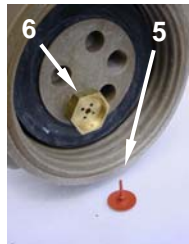

Figure 2. Preventive Maintenance Checks and Services – Fuel Can.

Table 1. Preventive Maintenance Checks and Services – Continued.

Item No.	Interval	Location Item to Check/ Service	Procedures	Equipment Not Ready/Available If:
6	Before	In-Tent Controller Assembly	<p style="text-align: center;">CAUTION</p> <p>Be sure to perform ONLY a visual check of the ON/OFF switch for damage. DO NOT flip the switch to the ON position.</p> <p>Perform a visual check of the in-tent controller assembly (Figure 3, Item 1) and verify that the ON/OFF switch (Figure 3, Item 2) and LOWER/HIGHER control (Figure 3, Item 3) are undamaged.</p> <p>Check five advisory lights and ensure that none are damaged:</p> <p style="text-align: center;">HEATER ON/ON HOLD (Figure 3, Item 4), BATTERY CHARGING (Figure 3, Item 5), BATTERY CHARGED (Figure 3, Item 6), SYSTEM FAULT (Figure 3, Item 7), and AT SETPOINT (Figure 3, Item 8).</p> <p>Verify that the ON/OFF switch (Figure 3, Item 2) is in OFF position, and the LOWER/HIGHER control (Figure 3, Item 3) is set at LOWER.</p> <p>Ensure that connector (Figure 3, Item 9) and its threads are clean and undamaged, and protective cap (Figure 3, Item 10) is firmly attached by the chain assembly (Figure 3, Item 11).</p>	<p>ON/OFF switch is damaged. LOWER/HIGHER control is damaged.</p> <p>Advisory lights are broken.</p> <p>Connector is dented or has stripped threads.</p>
7	Before	In-Tent Controller Assembly Cable	<p>Check in-tent controller cable (Figure 3, Item 12) and verify that insulation (Figure 3, Item 13) and connectors (Figure 3, Item 14) are clean and undamaged.</p>	<p>In-tent controller cable insulation is cut or otherwise damaged exposing wires.</p> <p>Connectors are dented, bent, or otherwise damaged, preventing a secure connection to the in-tent controller or heater.</p>

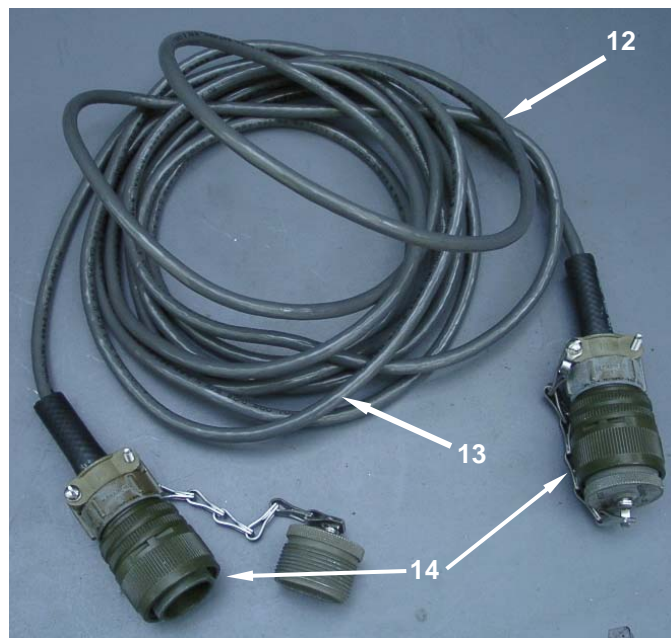
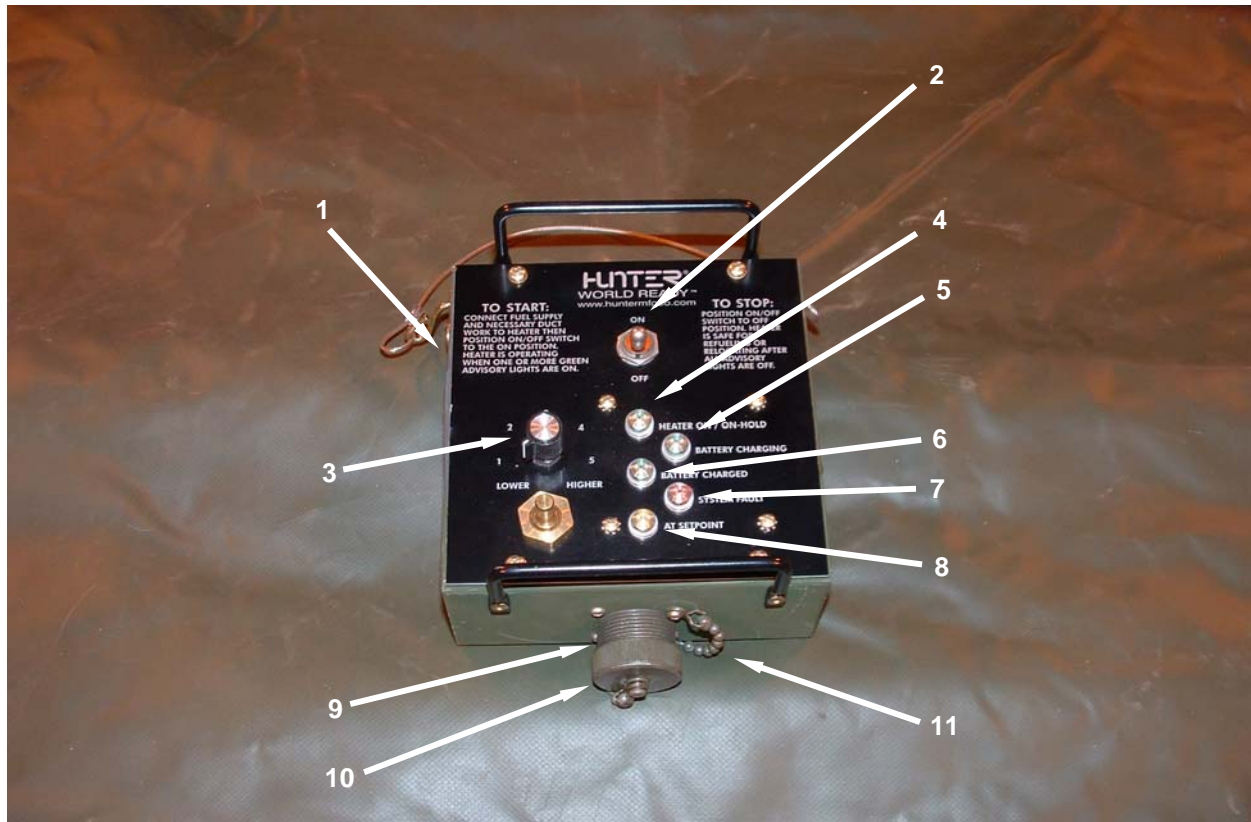

Figure 3. Preventive Maintenance Checks and Services – In-Tent Controller Assembly.

Table 1. Preventive Maintenance Checks and Services – Continued.

Item No.	Interval	Location Item to Check/ Service	Procedures	Equipment Not Ready/Available If:
8	Before	Control Connector (Lower Housing)	<p>Check control connector (Figure 4, Item 1) and ensure that it is not dented, bent, or otherwise damaged so as to prevent the in-tent controller cable from making a secure connection.</p> <p>Ensure that the connector does not contain dirt. Verify that the connector does not have stripped threads.</p>	<p>Connector is damaged.</p> <p>Connector is dirty. Connector has stripped threads.</p>
9	Before, During	Battery Pack	<p>Verify that the battery pack (Figure 4, Item 2) is securely connected to the lower housing connector (Figure 4, Item 3).</p> <p>Check the outer casing of the battery for cracks, cuts, or other physical damage.</p> <p>Check wires (Figure 4, Item 4) for cuts, breaks, or broken insulation.</p> <p>Check connector (Figure 4, Item 3) for damage or dirt.</p>	<p>Battery pack connector broken or will not connect to lower housing connector securely.</p> <p>Battery shows indications of physical damage.</p> <p>Wires leading from battery pack are cut, broken, or have cut insulation.</p> <p>Connector dirty or damaged.</p>
10	Before & During	Upper Housing Assembly	<p>Check for dents and damage. Make sure the upper housing (Figure 4, Item 5) fits smoothly into the slot (Figure 4, Item 6) on the circumference of the black exhaust grommet (Figure 4, Item 7). Ensure that all fasteners (Figure 4, Item 8) engage properly and secure the upper housing assembly.</p>	<p>Large dents or cracks in upper housing assembly. One or more fasteners are damaged and prevent the upper housing assembly from being secured.</p>
11	Before & During	External Fuel System	<p>Check external fuel system (Figure 4, Item 9) for leaks or evidence of leaks, including fuel hose (Figure 4, Item 10), fuel quick disconnect (Figure 4, Item 11), sediment strainer (Figure 4, Item 12) and connecting fittings (Figure 4, Item 13).</p> <p>Verify that fuel solenoid assembly wires (Figure 4, Item 14) are undamaged and that connectors (Figure 4, Item 15) are secure.</p> <p>Inspect and service the sediment strainer IAW procedures given in WP 0035 00.</p>	<p>There is any leakage within the heater, or there is a Class III leak anywhere. Stop operation of the heater and report leak to unit maintenance.</p> <p>Wiring damaged or loose connections</p> <p>Dirt, sludge, or water present in strainer bowl.</p>
12	Before & During	Combustion Air Inlet Assembly	<p>Check combustion air inlet assembly (Figure 4, Item 16) for dirt, debris, ice, or snow that could be sucked into heater. Ensure that there are no obstructions.</p>	<p>Combustion Air Inlet is obstructed or cover is damaged.</p>

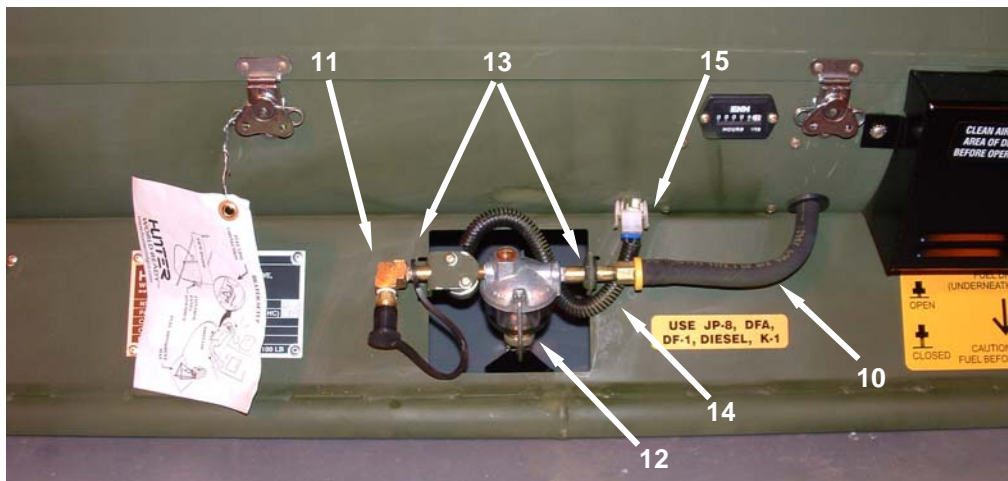
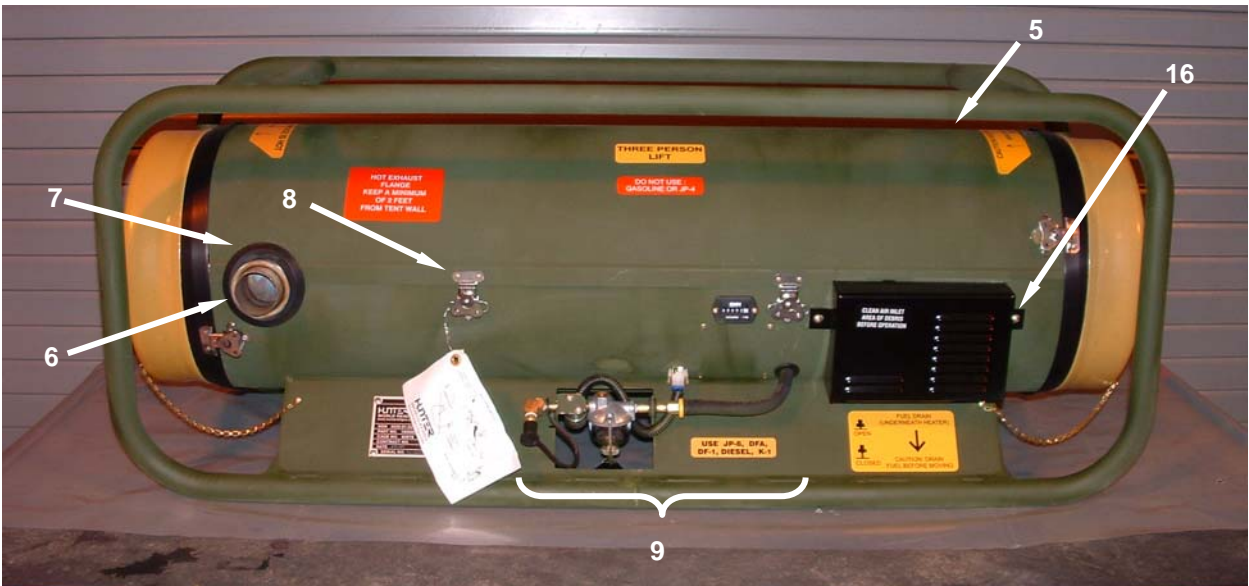
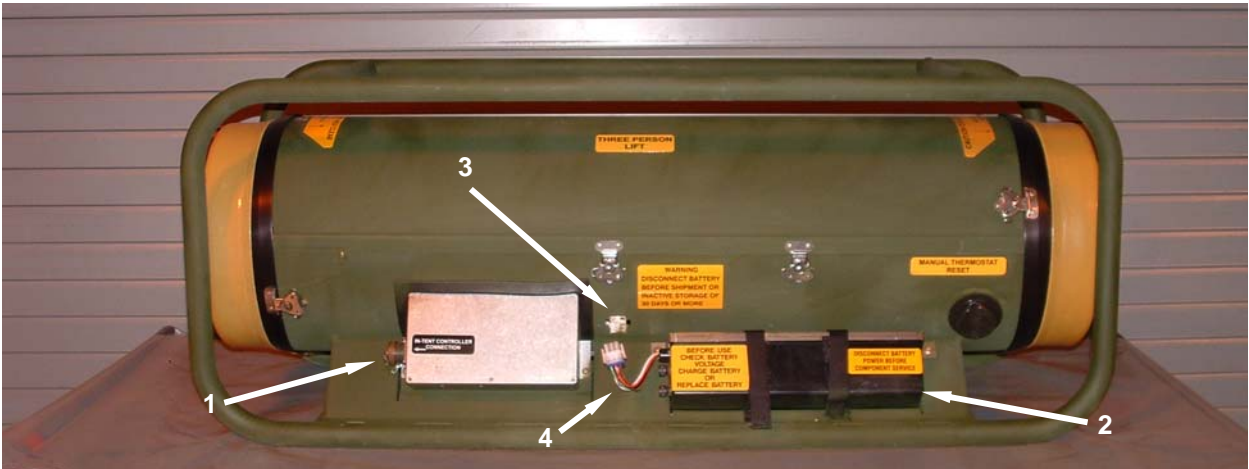

Figure 4. Preventive Maintenance Checks and Services – Continued.

Table 1. Preventive Maintenance Checks and Services – Continued.

Item No.	Interval	Location Item to Check/Service	Procedures	Equipment Not Ready/Available If:
13	Before	Manual Reset Thermostat	<p>Inspect rubber protector (Figure 5, Item 1) protecting the manual thermostat reset switch for holes, tears, or any other damage that would prevent it from protecting the reset switch (Figure 5, Item 2). Verify by hand that the switch is securely mounted and not damaged in any way.</p> <p>Verify that the connectors (Figure 5, Item 3) are firmly attached to the spade legs on the manual reset thermostat switch. Replace rubber protector.</p>	<p>Rubber protector (boot) is damaged.</p> <p>Manual reset thermostat switch is damaged or not securely mounted.</p> <p>Connections are loose</p>



Figure 5. Preventive Maintenance Checks and Services – Manual Reset Thermostat.

Table 1. Preventive Maintenance Checks and Services – Continued.

Item No.	Interval	Location Item to Check/ Service	Procedures	Equipment Not Ready/Available If:
14	Before & During	Lower Housing Assembly	Check lower housing assembly (Figure 6, Item 1) for dents and damage. Inspect frame (Figure 6, Item 2) for cracks and looseness.	Large dents or cracks in lower housing assembly. Damaged welds.
15	After	Fuel Drain Valve bottom of lower housing.	<div style="text-align: center;">  <p>WARNING</p> </div> <p>Leaking or spilled fuels will create a fire danger-injuries/death and environmental damage. Fuel spills must be cleaned up in accordance with local requirements.</p> <p>Check that fuel drain valve (Figure 6, Item 3) is tightly closed.</p> <p>Check the fuel drain valve for damage or corrosion.</p>	<p>Fuel Drain Valve leaks.</p> <p>Bent or damaged or can't turn. Corrosion prevents operation of valve.</p>
16	After	Dust Covers and Duct Adapters	<p>Check that the two dust covers (Figure 6, Item 4) and two duct adapters (Figure 6, Item 5) at the ends of the heater are firmly attached to the heater.</p> <p>Check dust covers for cracks and other physical damage.</p>	<p>Duct Adapters will not attach to heater.</p> <p>Duct Adapters damaged.</p>
17	Weekly	Battery Pack	<p>Verify that the battery retainer (Figure 6, Item 6) is not damaged and quarter turn screws (Figure 6, Item 7) are secure. Ensure straps (Figure 6, Item 8) are undamaged and secure</p> <p>Unscrew fuse caps (Figure 6, Item 9) and remove fuses (Figure 6, Item 10). Visually verify that fuses are not blown or damaged.</p>	<p>Battery retainer is damaged. Straps torn or chafed, or unsecured</p> <p>Fuses are blown and there are no spares.</p>

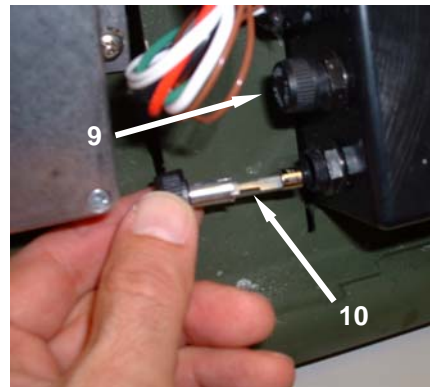
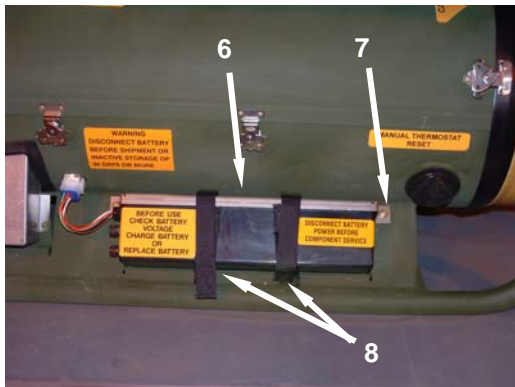
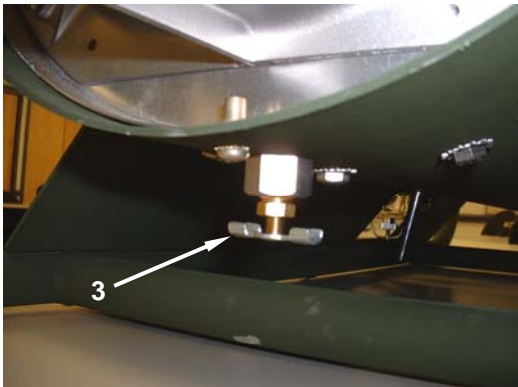

Figure 6. Preventive Maintenance Checks and Services – Lower Housing Assembly, Fuel Drain, Dust Covers, and Battery Pack.

Table 1. Preventive Maintenance Checks and Services – Continued.

Item No.	Interval	Location Item to Check/ Service	Procedures	Equipment Not Ready/Available If:
18	Weekly	Heater Interior	<p>Release four fasteners (Figure 7, Item 1) from their corresponding keeper plate (Figure 7, Item 2). Remove upper housing assembly (Figure 7, Item 3). Inspect interior of heater for:</p> <p>Any dirt or debris that could be blown through heat exchanger (Figure 7, Item 4) and into the tent must be removed. Remove dirt and debris using a clean rag. Pay special attention to cooling fins (Figure 7, Item 5) on the TEG that could trap bits of paper or other combustibles.</p> <p>Inspect float assembly (Figure 7, Item 6), fuel pump (Figure 7, Item 7), and fuel lines (Figure 7, Item 8) for damage or leakage.</p> <p>Check for any evidence of leaks. Notify Unit maintenance personnel based on leakage class described in WP 0032 00.</p> <p style="text-align: center;">NOTE</p> <p>The heater may be operated with Class I leaks within the heater, but they must be monitored to insure they do not get worse, pose a fire hazard, or cause the heated air being ducted to the tent to smell of fuel oil.</p>	<p>Dirt or other debris present inside heater.</p> <p>Damage to fuel system components</p> <p>Class III Leaks present inside heater.</p>
19	Weekly	Electrical Wires and Components	<p>Check electrical wires (Figure 7, Item 9), connectors (Figure 7, Item 10) and components for any evidence of overheating, arcing, or burning. Notify unit maintenance personnel.</p>	<p>Any wires or connectors broken or otherwise damaged.</p>
20	Weekly	Burner to TEG flange clamp	<p>Check that the burner to TEG flange clamp with nut (Figure 7, Item 11) is secure, and provides a leak proof seal between the burner and the TEG.</p>	<p>V-clamp with nut is loose or not secure on burner assembly and TEG.</p>
21	Weekly	Wrap Cover	<p>Check that the heat exchanger wrap cover (Figure 7, Item 12) is properly installed and tightly fastened down.</p>	<p>Wrap cover is loose.</p>
22	Weekly	Exhaust Grommet	<p>Check that black exhaust grommet (Figure 7, Item 13) is present and properly installed around the combustion exhaust outlet (Figure 7, Item 14) and is nestled in the cutout (Figure 7, Item 15) on the lower housing assembly.</p>	<p>Grommet missing or not properly installed.</p>

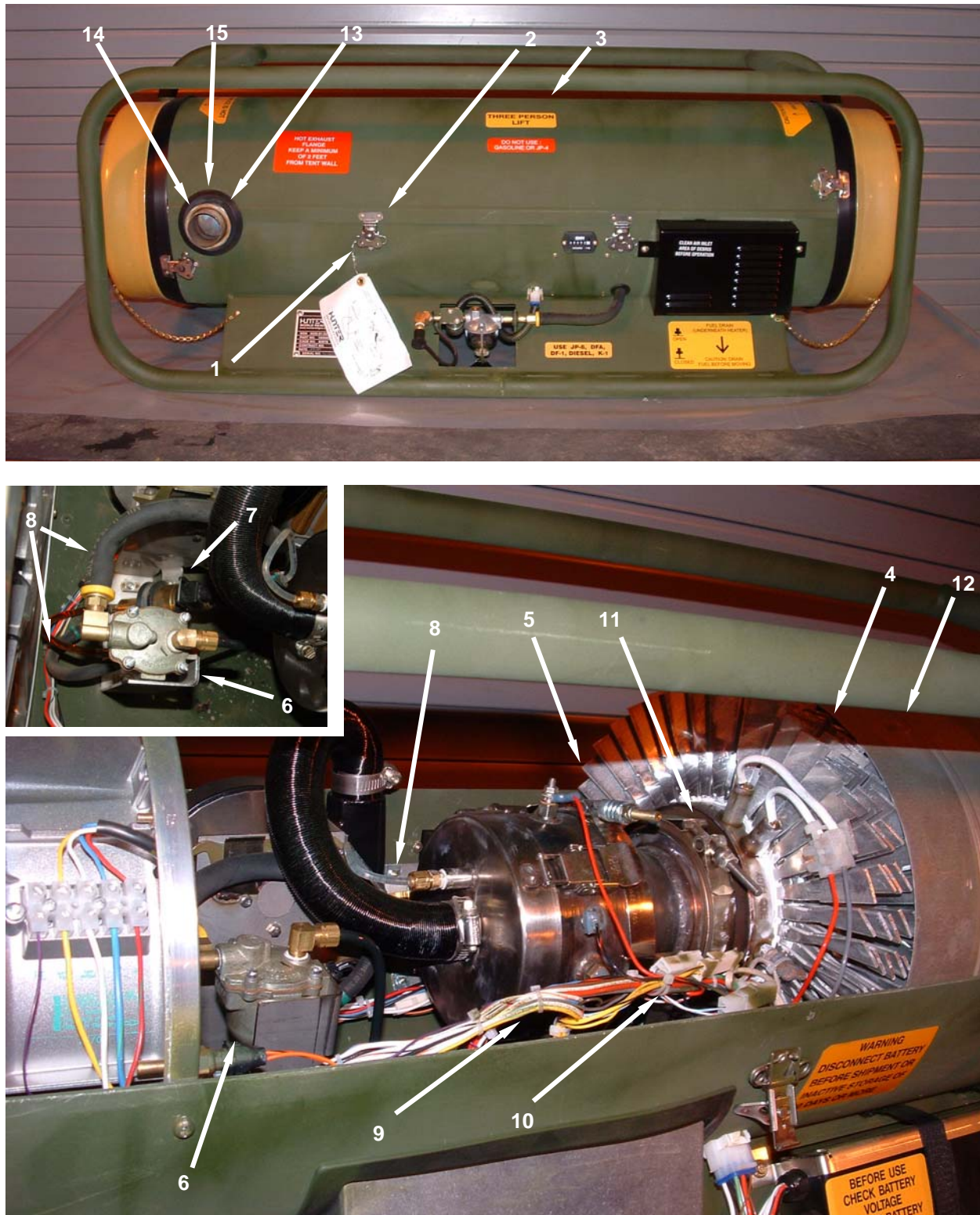

Figure 7. Preventive Maintenance Checks and Services – Heater Interior.

Table 1. Preventive Maintenance Checks and Services – Continued.

Item No.	Interval	Location Item to Check/ Service	Procedures	Equipment Not Ready/Available If:														
23	Weekly	Onboard Spares and Tools	<p>Check the spares and tool stowage area (Figure 8, Item 1) within the duct adapter at the inlet end (Figure 8, Item 2) of the heater. Confirm that all of the onboard spares and tools listed below are present. Order replacements for those which are missing.</p> <table border="1" data-bbox="626 541 1130 821"> <thead> <tr> <th data-bbox="626 541 1049 573">Name</th> <th data-bbox="1049 541 1130 573">Qty</th> </tr> </thead> <tbody> <tr> <td data-bbox="626 573 1049 604">Glow Plug (Figure 8, Item 3)</td> <td data-bbox="1049 573 1130 604">1</td> </tr> <tr> <td data-bbox="626 604 1049 636">Flame Sensor (Figure 8, Item 4)</td> <td data-bbox="1049 604 1130 636">1</td> </tr> <tr> <td data-bbox="626 636 1049 678">Battery Pack Fuses (20 Amp) (Figure 8, Item 5)</td> <td data-bbox="1049 636 1130 678">2</td> </tr> <tr> <td data-bbox="626 678 1049 709">Wrench (Figure 8, Item 6)</td> <td data-bbox="1049 678 1130 709">1</td> </tr> <tr> <td data-bbox="626 709 1049 762">Sediment strainer gasket (Figure 8, Item 7)*</td> <td data-bbox="1049 709 1130 762">1</td> </tr> <tr> <td data-bbox="626 762 1049 821">Sediment strainer screen (Figure 8, Item 8)*</td> <td data-bbox="1049 762 1130 821">1</td> </tr> </tbody> </table> <p>* stored in plastic bag (Figure 8, Item 9) tied to frame in outlet fan.</p> <p>Ensure that wrench is secured to the combustion air inlet assembly.</p> <p>Ensure that the Battery Charging Adapter (Figure 8, Item 10) is included with the other accessory items in the accessory bag.</p>	Name	Qty	Glow Plug (Figure 8, Item 3)	1	Flame Sensor (Figure 8, Item 4)	1	Battery Pack Fuses (20 Amp) (Figure 8, Item 5)	2	Wrench (Figure 8, Item 6)	1	Sediment strainer gasket (Figure 8, Item 7)*	1	Sediment strainer screen (Figure 8, Item 8)*	1	Heater may be operated without these spares and tool.
Name	Qty																	
Glow Plug (Figure 8, Item 3)	1																	
Flame Sensor (Figure 8, Item 4)	1																	
Battery Pack Fuses (20 Amp) (Figure 8, Item 5)	2																	
Wrench (Figure 8, Item 6)	1																	
Sediment strainer gasket (Figure 8, Item 7)*	1																	
Sediment strainer screen (Figure 8, Item 8)*	1																	
24	Every 1000 Operating Hours or as needed	Burner Assembly	If the heater is run on diesel fuel or if experiencing burner maintenance fault codes, clean the burner IAW procedures in WP 0036 00.	Maintenance not performed at specified interval														

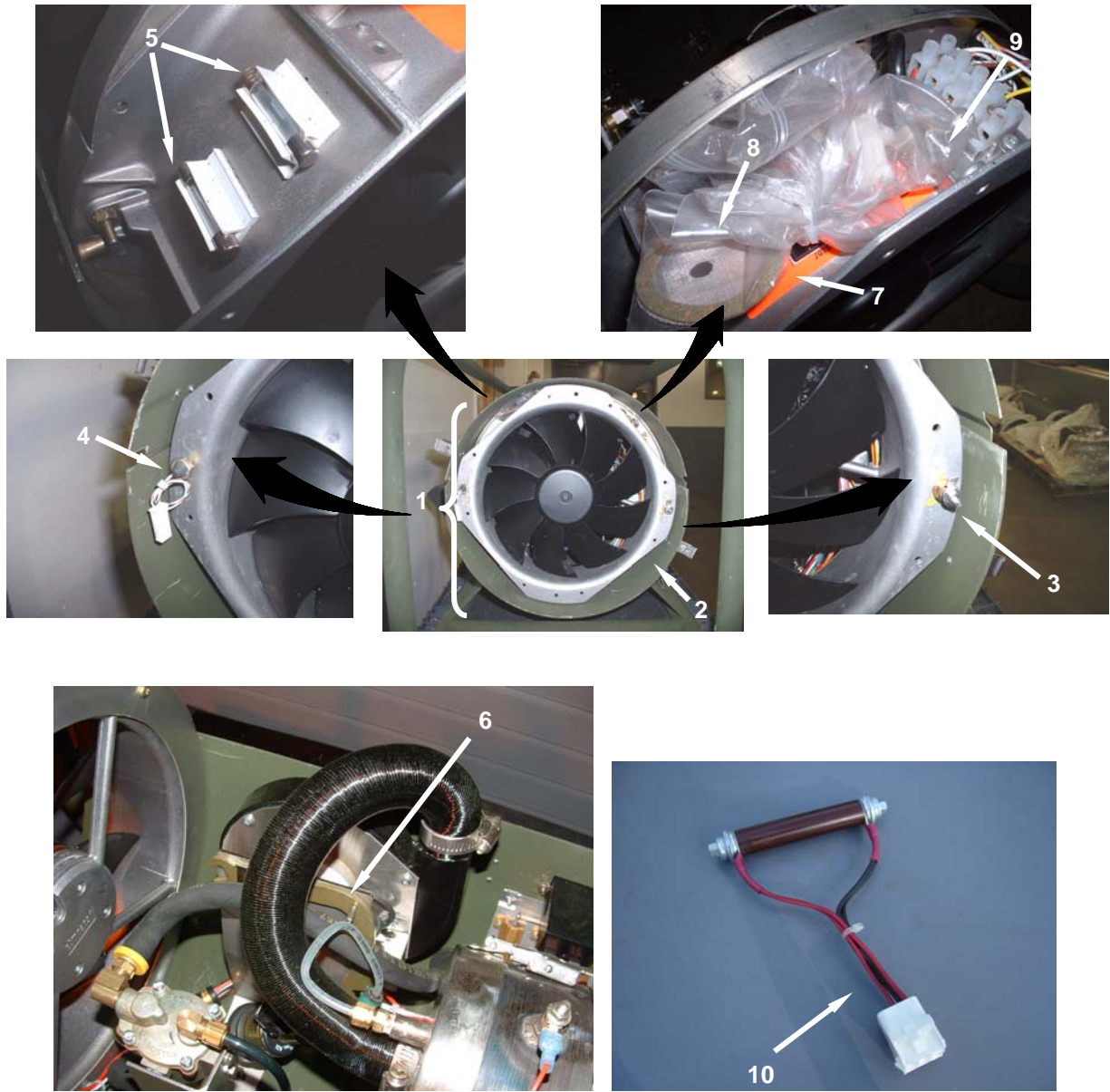

Figure 8. Preventive Maintenance Checks and Services – Onboard Spares and Tools.

LUBRICATION INSTRUCTIONS

Lubricate the heater with silicone lubricant in accordance with Table 2.



Table 2. Lubrication Instructions.

COMPONENT	LUBRICANT/ AMOUNT	TEMPERATURE	INTERVAL	MAN HOUR
All fasteners (1)	Light coating of silicone lubricant (WP 0092, Item 10)	All temperatures	As required	0.1

END OF WORK PACKAGE

**OPERATOR'S MAINTENANCE
SPACE HEATER, CONVECTIVE 60K BTU (SHC-60K)
NSN 4520-01-520-6477
OPERATOR MAINTENANCE PROCEDURES**

INTRODUCTION

NOTE

Maintenance programs must be followed in the applicable technical manuals. It is very important to adhere to maintenance procedures in order to prolong the service life of these items.

This TM contains Operator Maintenance procedures applicable to the SHC-60K as authorized by the Maintenance Allocation Chart (MAC) in WP 0067 00 of this manual. If applicable, refer to associated equipment technical manuals for item-specific maintenance instructions (refer to WP 0065 00 for technical manual information). All maintenance instructions covered in this work package are unique to the SHC-60K.

All maintenance procedures in this work package can be performed by one person unless otherwise indicated. Read all **WARNINGS**, **CAUTIONS**, and **NOTES** carefully before attempting any procedures. This includes the warnings at the front of this manual.

Operator Maintenance Work Packages begin with a header specifying the applicable equipment, the item being maintained, and what the maintenance action entails. This is followed by a chart specifying the initial setup of the equipment before starting maintenance, the tools required to perform the maintenance, any materials or parts required, and the number of MOS specific personnel required. Maintenance items which do not list an MOS for the task are non-MOS specific Maintenance items.

Operator Maintenance tasks may be performed by Operator or Unit Maintenance personnel.

**OPERATOR'S MAINTENANCE
SPACE HEATER, CONVECTIVE 60K BTU (SHC-60K)
NSN 4520-01-520-6477
FUEL SOLENOID VALVE AND SEDIMENT STRAINER ASSEMBLY
INSPECT, SERVICE, REPLACE**

INITIAL SETUP:**Tools**

None Required

Personnel Required

One

Materials/Parts

Baled Rag, General (Item 3, WP 0092 00)
Mat, Petroleum Absorbent (Item 11, WP 0092
00)

Equipment Condition

Heater shut down and cool, and all advisory
lights off (WP 0006 00).
In-tent controller assembly disconnected from
heater (WP 0006 00).
Battery disconnected (WP 0006 00).
Fuel supply disconnected (WP 0006 00).

INSPECT**Inspect Fuel Solenoid and Sediment Strainer Assembly****WARNING**

Be sure to disconnect battery connector before performing any maintenance actions. Failure to do so may cause sparking or short circuits which might cause a fire or damage heater components.

1. Inspect the sediment strainer (**Figure 1, Item 1**) for any cracks, dents, or other damage that would cause leaks or restrict the flow of fuel from the fuel solenoid valve (**Figure 1, Item 2**) to the fuel hose (**Figure 1, Item 3**).
2. Ensure that there are no fuel leaks at the fittings (**Figure 1, Item 4**) or around the bowl area (**Figure 1, Item 5**) of the strainer.
3. Inspect the sediment strainer bowl (**Figure 1, Item 5**) for the presence of dirt, water, or sediment. If necessary, clean the sediment bowl IAW the following SERVICE procedure.
4. Inspect the fuel solenoid valve (**Figure 1, Item 2**) for any cracks, dents, or other damage that would inhibit its proper operation or restrict the flow of fuel from the fuel solenoid valve (**Figure 1, Item 2**) to the sediment strainer (**Figure 1, Item 1**).
5. Ensure that the wires (**Figure 1, Item 6**) protected by the wire loom (**Figure 1, Item 7**) and leading to the fuel solenoid valve (**Figure 1, Item 1**) do not have any cuts or abrasions.
6. Inspect the connectors (**Figure 1, Item 8**) for any cracks or other damage that would prevent the connectors from having a secure electrical connection.

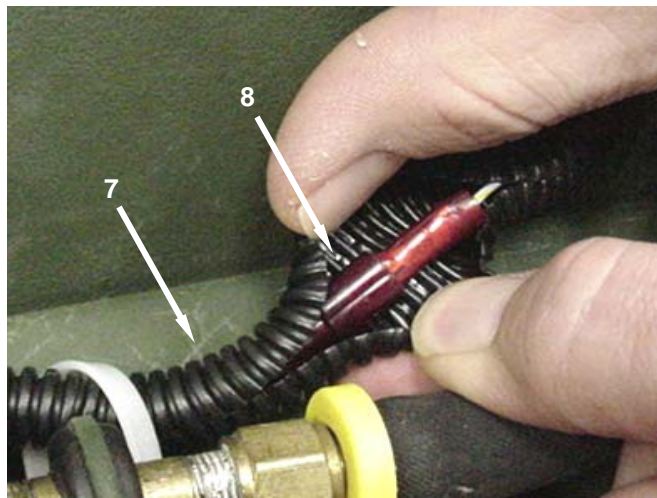
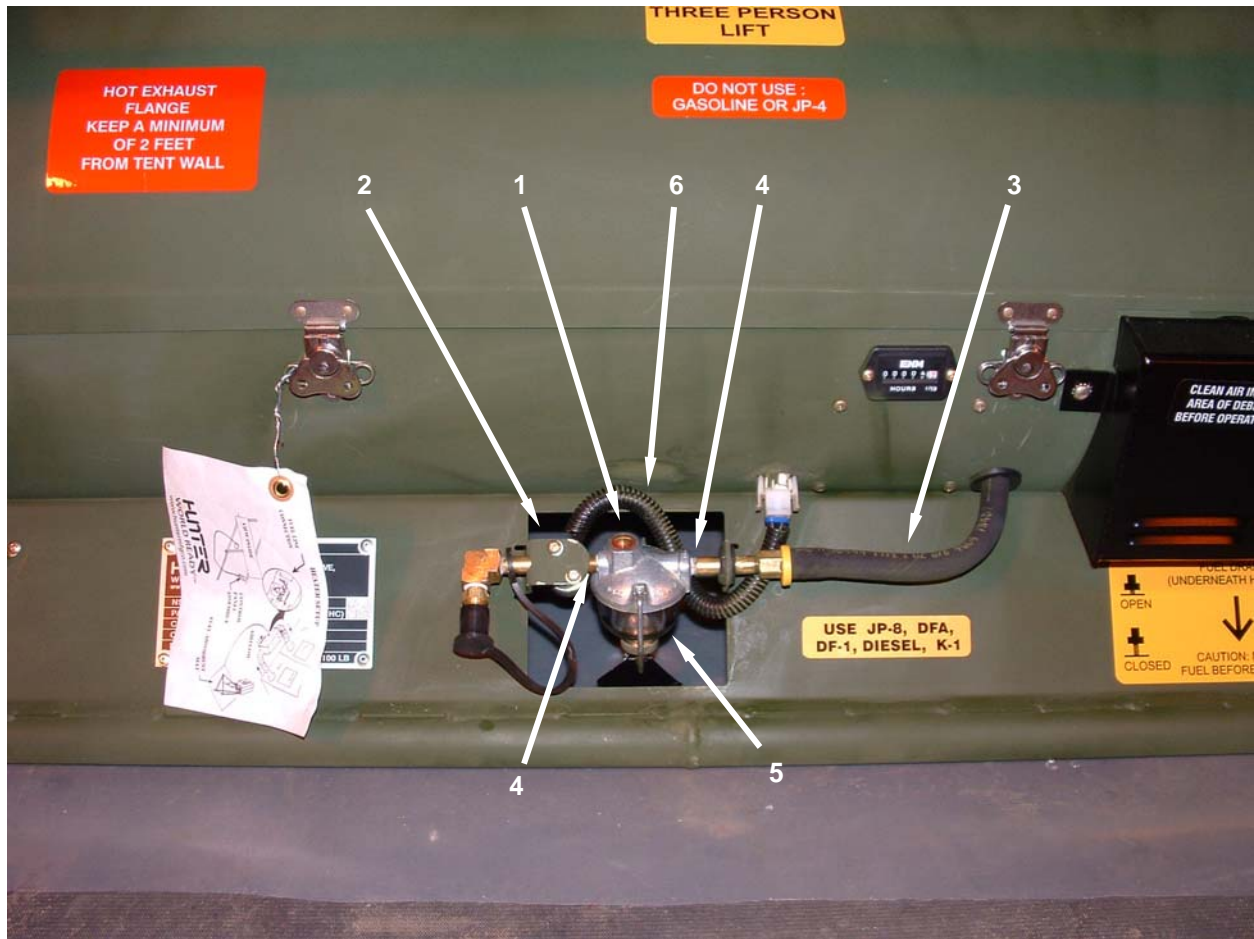

Figure 1. Inspect Fuel Solenoid and Sediment Strainer Assembly.

SERVICE

Service Fuel Solenoid and Sediment Strainer Assembly

1. To clean and service the sediment strainer (**Figure 2, Item 1**), first place a petroleum absorbent mat under the heater in the area of the sediment strainer.
2. Loosen the knurled nut (**Figure 2, Item 2**) at the base of the sediment strainer bowl (**Figure 2, Item 3**).
3. Rotate the bale (**Figure 2, Item 4**) to the right and upward while supporting the bowl (**Figure 2, Item 3**).
4. Rock the bowl (**Figure 2, Item 3**) slightly and remove it from the sediment strainer top assembly (**Figure 2, Item 5**).



WARNING

Fuels are toxic. Wear eye/face protection, impervious hand protection, avoid contact with skin and clothes, and don't breathe vapors. The use of protective gloves will significantly reduce the risks of exposure by prevent contact with skin. If contact with eyes or skin is made, immediately flush with clean water and get medical aid for eyes. If contact with clothing or skin is made, immediately remove contaminated clothing and clean skin with mild soap or cleanser and flush with clean water. Failure to observe these precautions could result in exposure to fuel, resulting in serious illness.

NOTE

Manage and dispose of fuel and fuel absorbent pads or wipes in accordance with appropriate state, local, and installation environmental regulations.

5. Empty the fuel from the bowl (**Figure 2, Item 3**) into an approved container and discard. Do not empty the fuel into a fresh fuel supply. Wipe the bowl clean with a lint-free rag or wiping towel.

CAUTION

A knife tip or small screwdriver may be needed to remove the strainer. If this is necessary, notify unit maintenance.

6. Remove the gasket (**Figure 2, Item 6**) and screen (**Figure 2, Item 7**) from the sediment strainer top assembly (**Figure 2, Item 5**).
7. Rinse the gasket (**Figure 2, Item 6**) and screen (**Figure 2, Item 7**) in clean approved fuel, ensuring all sediment is removed.

CAUTION

Ensure the gasket is clean and undamaged before reinstalling into he sediment strainer. Replace a damaged or otherwise unserviceable gasket. Do not use gasket sealers or RTV to repair or replace a damaged gasket.

8. Install the gasket (Figure 2, Item 6) and screen (Figure 2, Item 7) in position on the sediment strainer top assembly (Figure 2, Item 5).
9. Replace the bowl (Figure 2, Item 3) under the sediment strainer top assembly (Figure 2, Item 5).
10. Rotate the bale (Figure 2, Item 4) downward and center under the bowl (Figure 2, Item 3).
11. Tighten knurled nut (Figure 2, Item 2) at base of sediment strainer bowl (Figure 2, Item 3).
12. Operate the SHC-60K IAW procedures given in WP 0006 00 and monitor for normal operation and leakage.

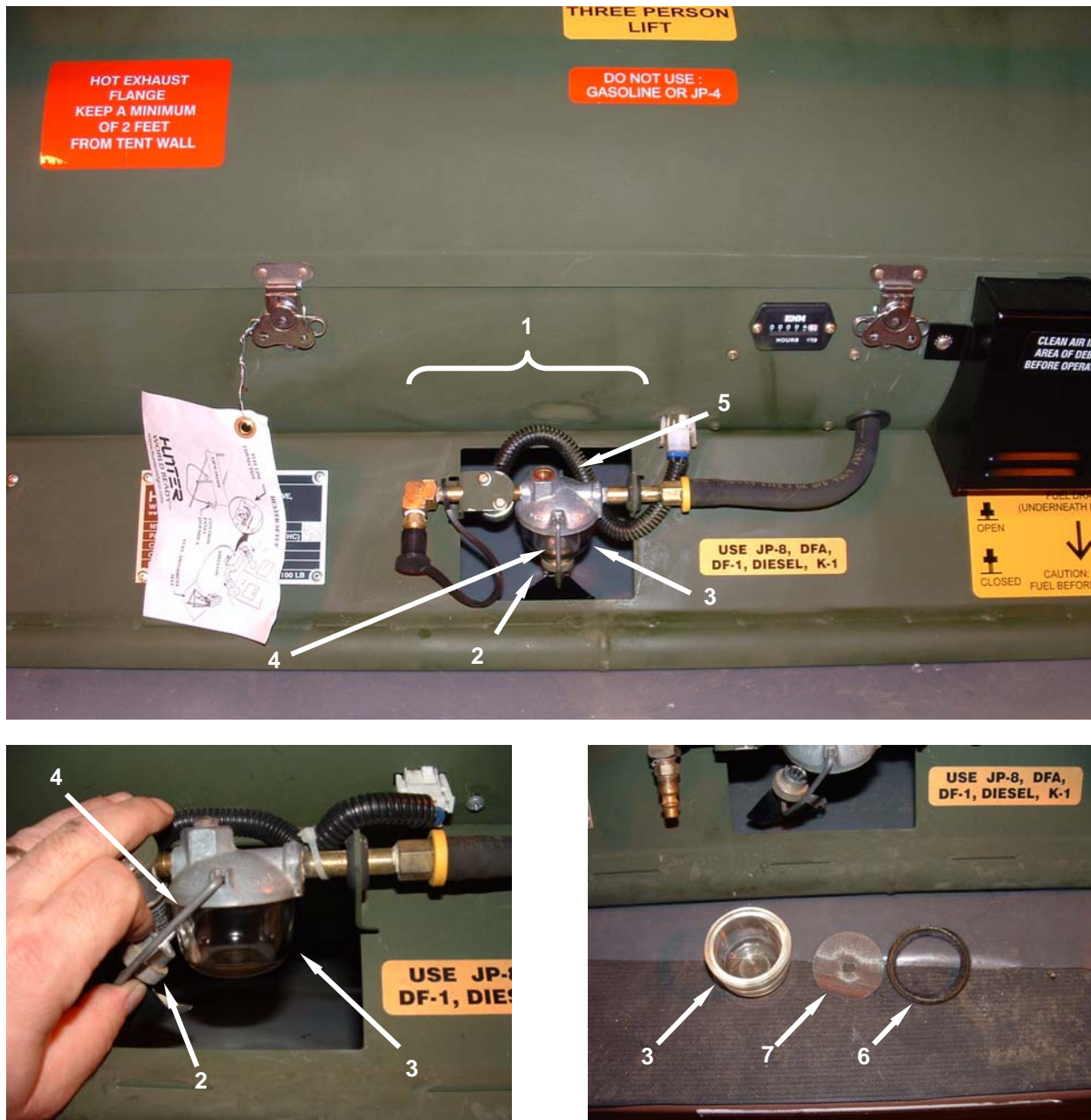

Figure 2. Service Fuel Solenoid and Sediment Strainer Assembly.

REPLACE

Replace the Sediment Strainer

1. To replace the sediment strainer (**Figure 3, Item 1**), first place a petroleum absorbent mat under the heater in the area of the sediment strainer.
2. Loosen the knurled nut (**Figure 3, Item 2**) at the base of the sediment strainer bowl (**Figure 3, Item 3**).
3. Rotate the bale (**Figure 3, Item 4**) to the right and upward while supporting the bowl (**Figure 3, Item 3**).
4. Rock the bowl (**Figure 3, Item 3**) slightly and remove it from the sediment strainer top assembly (**Figure 3, Item 5**).



WARNING

Fuels are toxic. Wear eye/face protection, impervious hand protection, avoid contact with skin and clothes, and don't breathe vapors. The use of protective gloves will significantly reduce the risks of exposure by prevent contact with skin. If contact with eyes or skin is made, immediately flush with clean water and get medical aid for eyes. If contact with clothing or skin is made, immediately remove contaminated clothing and clean skin with mild soap or cleanser and flush with clean water. Failure to observe these precautions could result in exposure to fuel, resulting in serious illness.

NOTE

Manage and dispose of fuel and fuel absorbent pads or wipes in accordance with appropriate state, local, and installation environmental regulations.

5. Empty the fuel from the bowl (**Figure 3, Item 3**) into an approved container and discard. Do not empty the fuel into a fresh fuel supply.

CAUTION

A knife tip or small screwdriver may be needed to remove strainer. If this is necessary, notify unit maintenance.

6. Remove the gasket (**Figure 3, Item 6**) and screen (**Figure 3, Item 7**) from the sediment strainer top assembly (**Figure 3, Item 5**) and discard in an approved manner.
7. Install a new gasket (**Figure 3, Item 6**) and screen (**Figure 3, Item 7**) in position on the sediment strainer top assembly (**Figure 3, Item 5**).
8. Replace the bowl (**Figure 3, Item 3**) under the sediment strainer top assembly (**Figure 3, Item 5**).
9. Rotate the bale (**Figure 3, Item 4**) downward and center under the bowl (**Figure 3, Item 3**).
10. Tighten knurled nut (**Figure 3, Item 2**) at base of sediment strainer bowl (**Figure 3, Item 3**).

11. Operate the SHC-60K IAW procedures given in WP 0006 00 and monitor for normal operation and leakage.

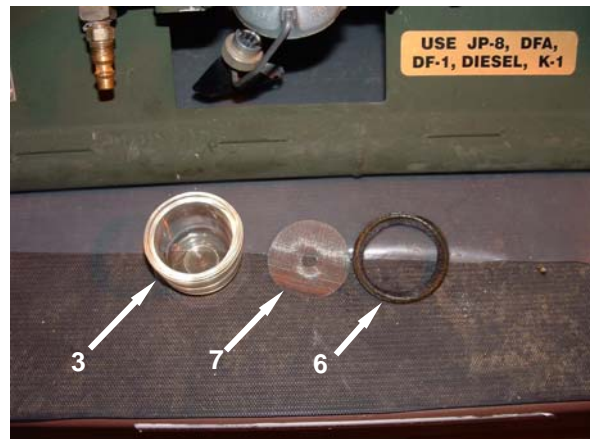
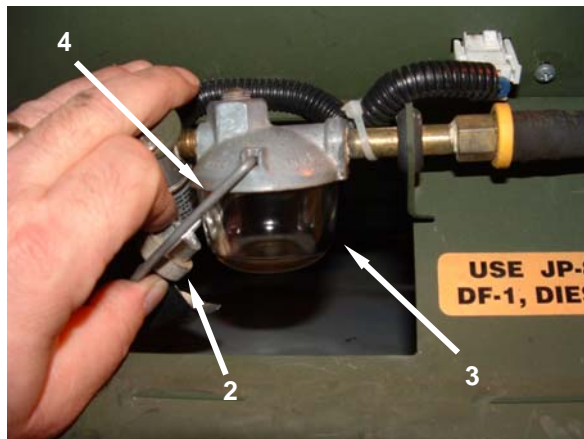
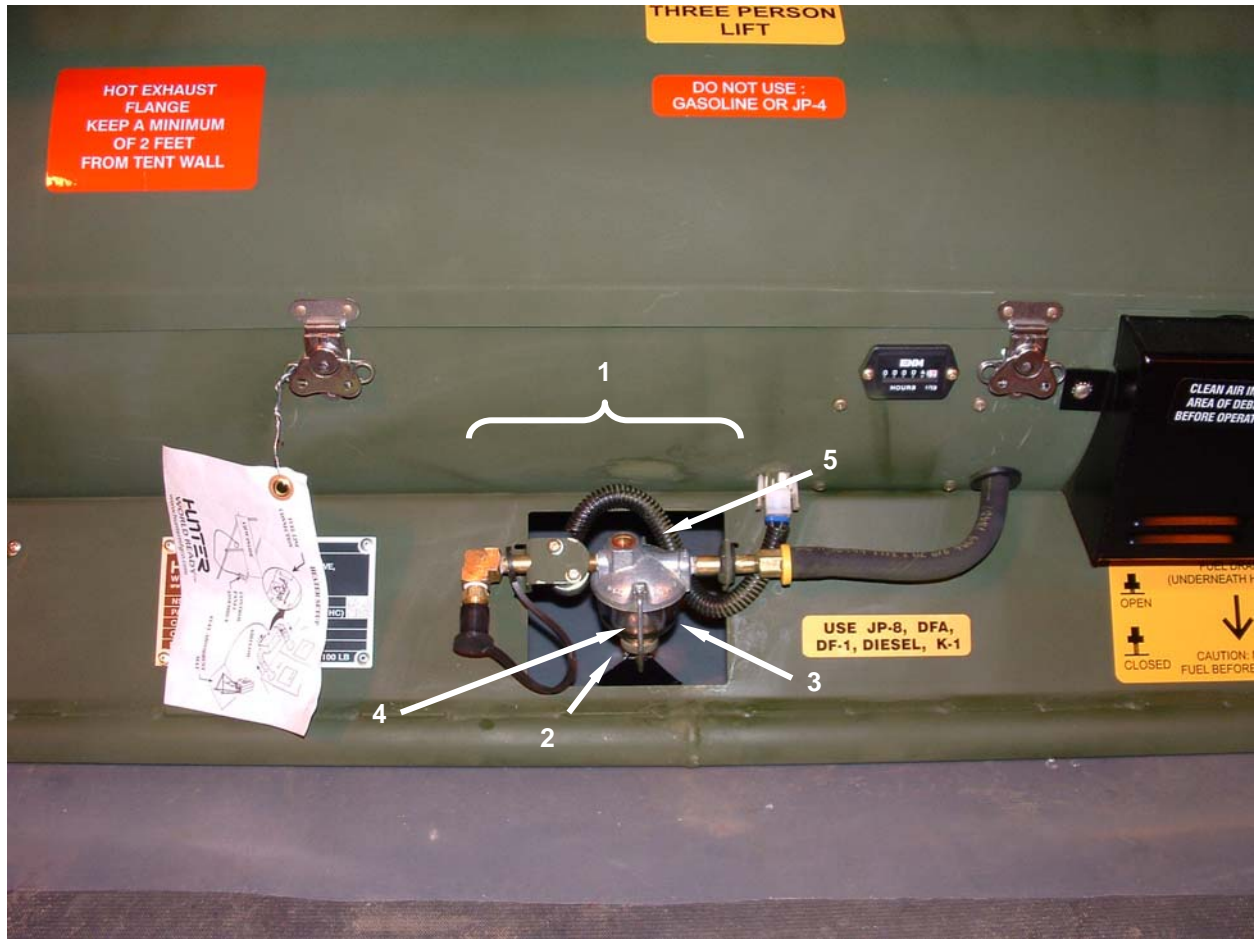

Figure 3. Replace the Sediment Strainer.

END OF WORK PACKAGE

**OPERATOR'S MAINTENANCE
SPACE HEATER, CONVECTIVE 60K BTU (SHC-60K)
NSN 4520-01-520-6477
BURNER ASSEMBLY AND WICK
INSPECT, SERVICE, REPLACE**

INITIAL SETUP:**Tools**

None Required

Personnel Required

Two

Materials/Parts

Baled Rag, General (Item 3, WP 0092 00)

Equipment Condition

Heater shut down, cool, and all advisory lights off (WP 0006 00).

In-tent controller assembly disconnected from heater (WP 0006 00).

Fuel supply disconnected (WP 0006 00).

INSPECT**Inspect the Burner Assembly****WARNING**

Be sure to disconnect battery connector before performing any maintenance procedures. Failure to do so may cause sparking or short circuits which might cause a fire or damage heater components.

**WARNING**

Promptly wipe up any spilled fuel. Dispose of fuel in a safe manner. Failure to do so will create a fire hazard and potentially cause an environmental hazard as well.

NOTE

It is not necessary to remove the combustion air hose or the fuel line from the burner cover.

1. Disconnect battery pack connector (**Figure 1, Item 1**) from lower housing assembly.
2. Remove the upper housing assembly (**Figure 1, Item 2**) by first removing the two dust covers (**Figure 1, Item 3**) at the inlet and outlet ends of the heater.
3. Remove the two duct adapters (**Figure 1, Item 4**) at the inlet and outlet end of the heater by releasing the two fastener housings (**Figure 1, Item 5**) from the fastener keepers (**Figure 1, Item 6**).

4. Remove the upper housing assembly (**Figure 1, Item 2**) by releasing the remaining fastener housings (**Figure 1, Item 7**) from their corresponding fastener keepers (**Figure 1, Item 8**). Lift and remove the upper housing assembly (**Figure 1, Item 1**). Set the upper housing assembly aside.

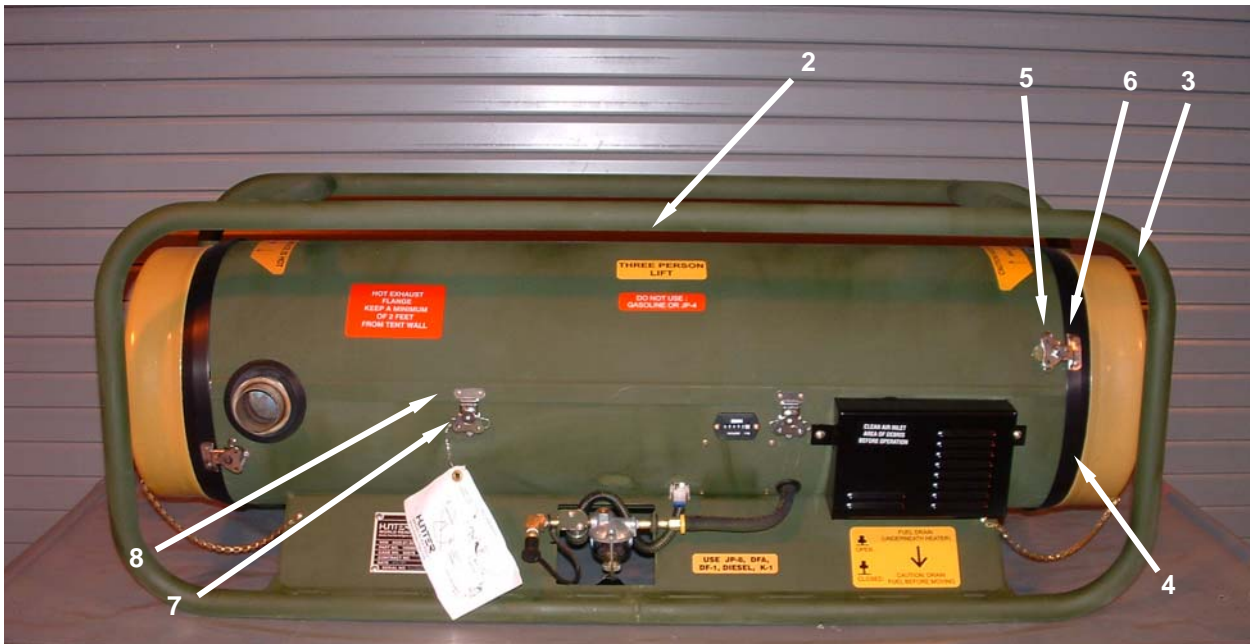

Figure 1. Inspect Burner Assembly.

5. Release three clamps (**Figure 2, Item 9**) to open cover (**Figure 2, Item 10**) of burner assembly (**Figure 2, Item 11**), then position clamps behind retainers on cover as shown. Lower the clamps to gently pry the cover from the burner.
6. Inspect wick (**Figure 3, Item 1**) for excessive carbon deposits and physical damage.
7. Inspect the interior of the burner for carbon deposits. Clean carbon deposits from burner assembly IAW procedures given in this work package
8. Ensure sealing ring (**Figure 3, Item 2**) is in place and undamaged.
9. Install cover (**Figure 3, Item 3**) and secure with latches (**Figure 3, Item 4**). Ensure cover is tight.
10. Reinstall upper housing and duct adapter, and operate the SHC-60K IAW WP 0006 00. Monitor for normal operation.

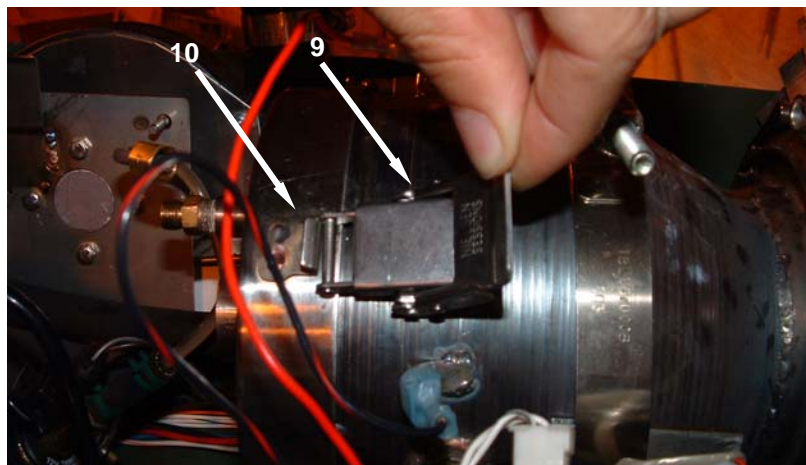
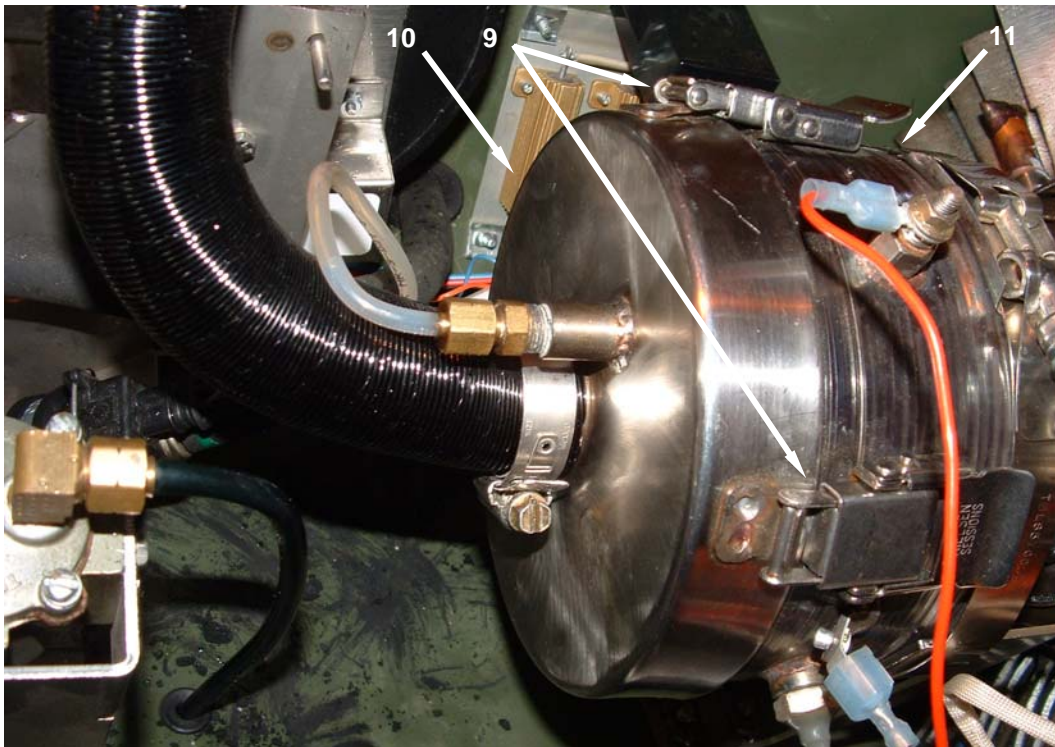

Figure 2. Inspect Burner Assembly - Continued.

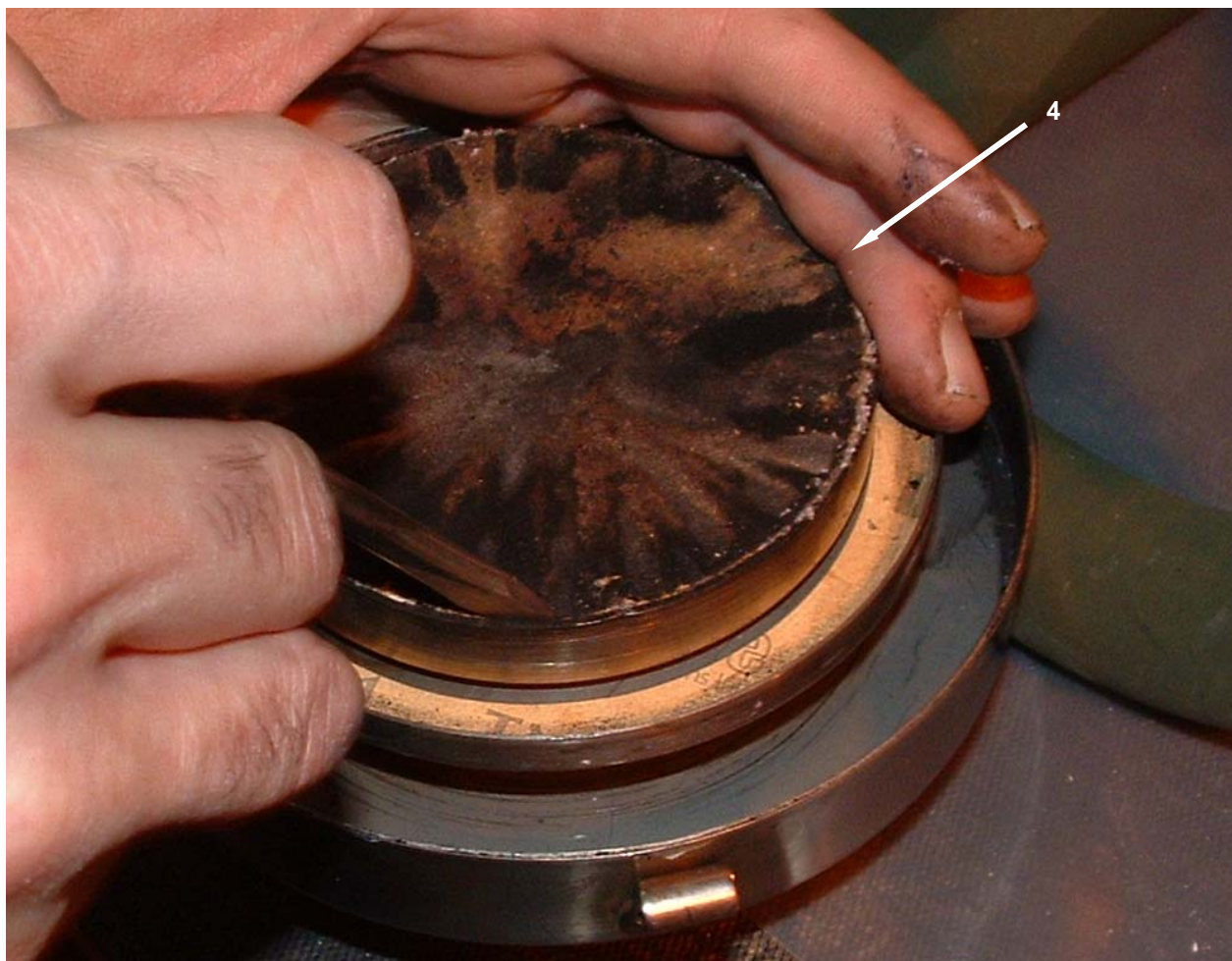
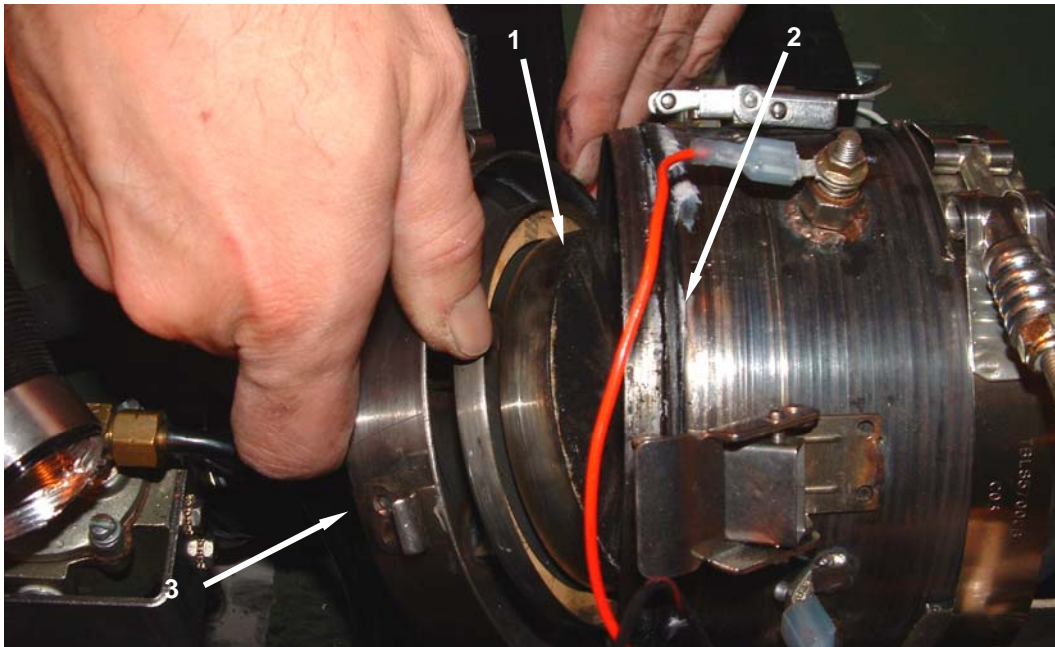

Figure 3. Inspect Burner Assembly - Continued.

SERVICE**Clean the Burner Assembly****WARNING**

Be sure to disconnect battery connector before performing any maintenance procedures. Failure to do so may cause sparking or short circuits which might cause a fire or damage heater components.

**WARNING**

Leaking or spilled fuels will create a fire hazard and environmental damage. Fuel spills are to be cleaned up IAW local requirements.

1. Disconnect battery pack connector (**Figure 4, Item 1**) from lower housing assembly.
2. Remove the upper housing assembly (**Figure 4, Item 2**) by first removing the two dust covers (**Figure 4, Item 3**) at the inlet and outlet ends of the heater.
3. Remove the two duct adapters (**Figure 4, Item 4**) at the inlet and outlet end of the heater by releasing the two fastener housings (**Figure 4, Item 5**) from the fastener keepers (**Figure 4, Item 6**).
4. Remove the upper housing assembly (**Figure 4, Item 2**) by releasing the remaining fastener housings (**Figure 4, Item 7**) from their corresponding fastener keepers (**Figure 4, Item 8**). Lift and remove the upper housing assembly (**Figure 4, Item 1**). Set the upper housing assembly aside.

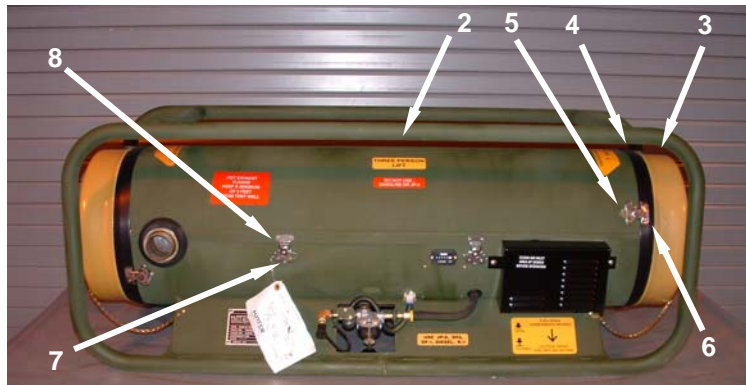

Figure 4. Clean the Burner Assembly.

5. Release three clamps (**Figure 5, Item 1**) to open cover (**Figure 5, Item 2**) of burner assembly (**Figure 5, Item 3**), then position clamps behind retainers on cover as shown. Lower the clamps to gently prise the cover from the burner.

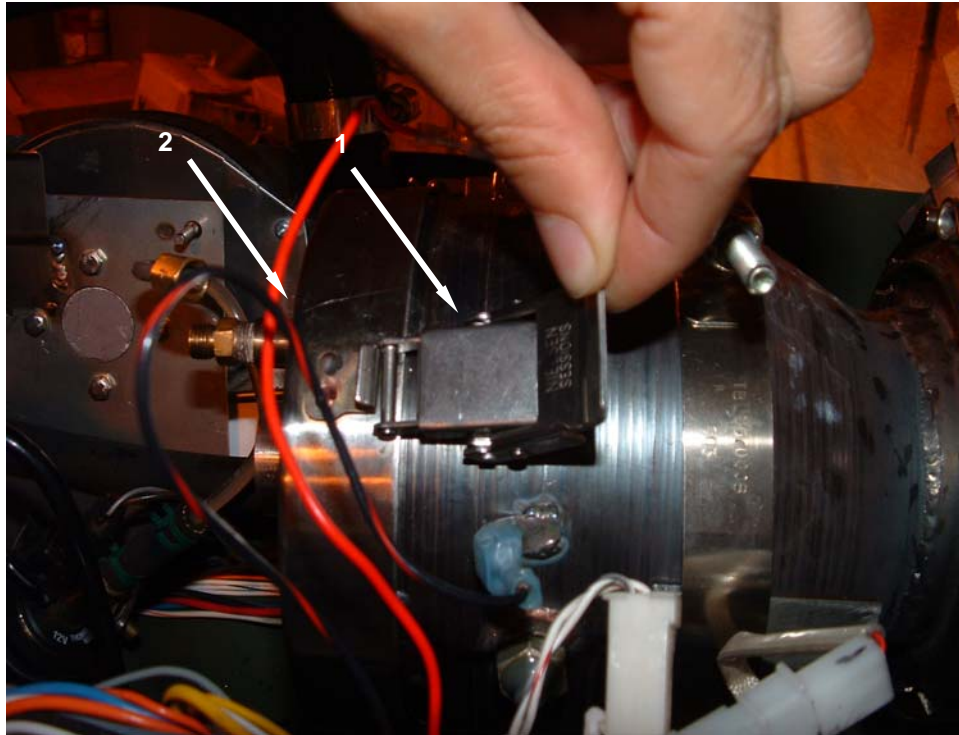
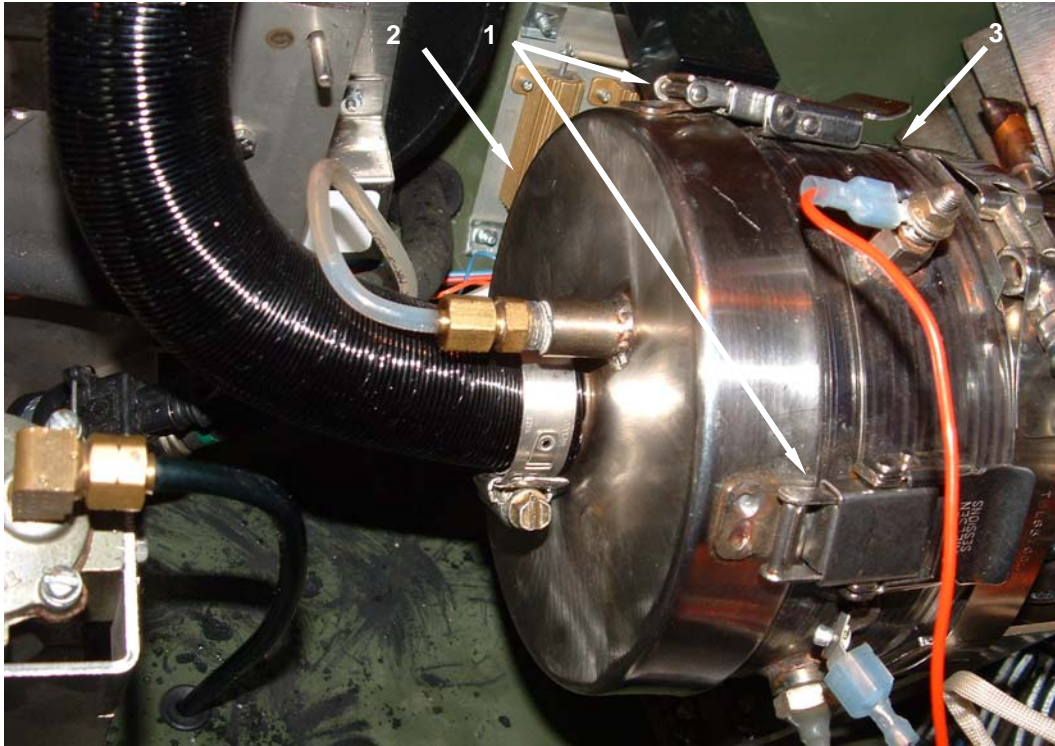

Figure 5. Inspect Burner Assembly - Continued.

CAUTION

Use caution when cleaning the wick. A screwdriver, knife, or the supplied wrench may be used to scrape off carbon deposits without removing or gouging the base material and damaging the wick. If a significant amount of base material has been removed, the maintainer should consider replacement of the component.

6. Gently wipe wick (**Figure 6, Item 1**) clear of excessive carbon deposits. Tap the wick lightly, and use the edge of the supplied wrench to gently scrape away carbon deposits. Take care not to remove the base material.
7. Wipe the cavity (**Figure 6, Item 2**) of the burner assembly clean of loose carbon deposits.
8. Install cover (**Figure 6, Item 3**) and secure with latches (**Figure 6, Item 4**). Ensure cover is tight.
9. Reinstall upper housing and duct adapter, and operate the SHC-60K IAW WP 0006 00. Monitor for normal operation.

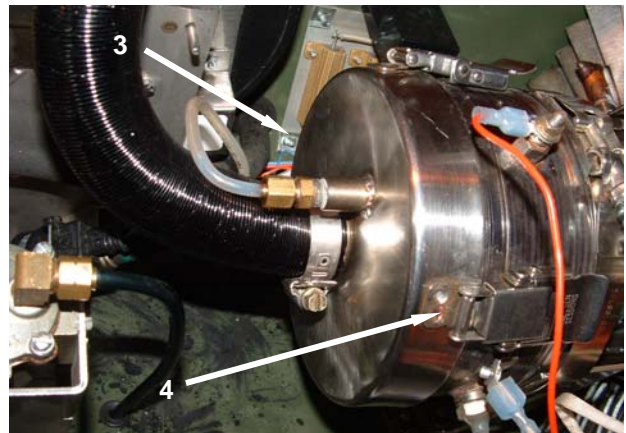
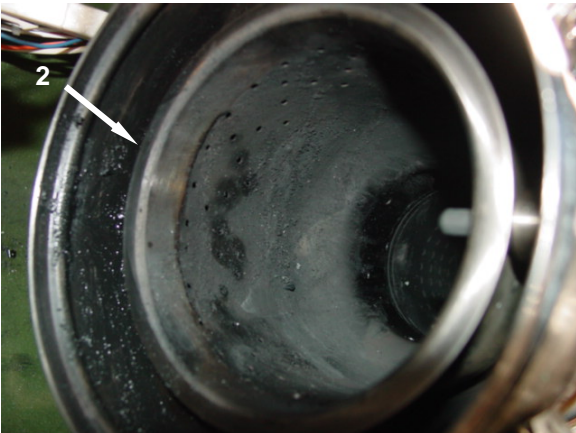
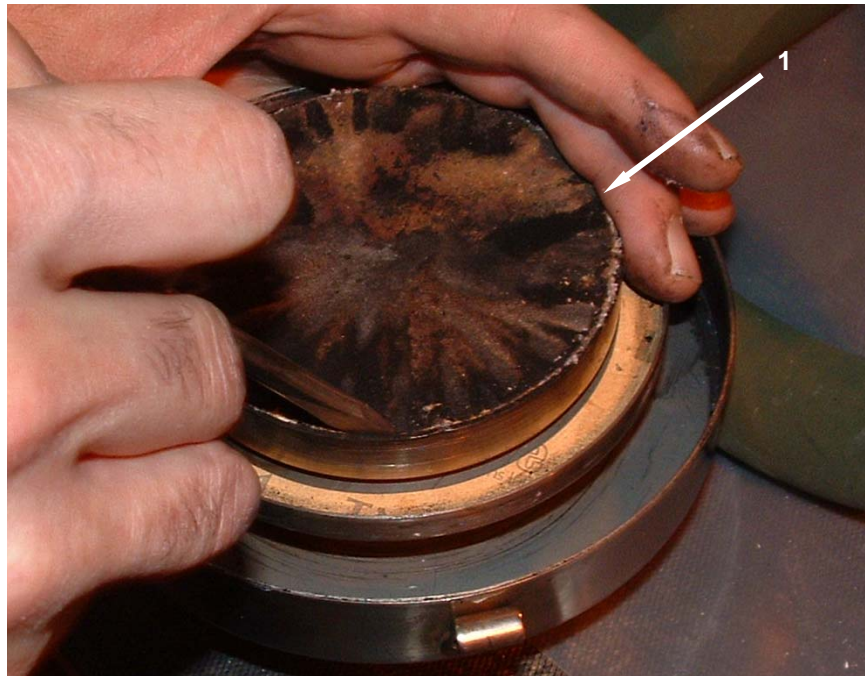

Figure 6. Service Burner Assembly - Continued.

REPLACE**Replace the Burner Assembly Wick****WARNING**

Be sure to disconnect battery connector before performing any maintenance procedures. Failure to do so may cause sparking or short circuits which might cause a fire or damage heater components.

**WARNING**

Leaking or spilled fuels will create a fire hazard and environmental damage. Fuel spills are to be cleaned up IAW local requirements.

1. Disconnect battery pack connector (**Figure 7, Item 1**) from lower housing assembly.
2. Remove the upper housing assembly (**Figure 7, Item 2**) by first removing the two dust covers (**Figure 7, Item 3**) at the inlet and outlet ends of the heater.
3. Remove the two duct adapters (**Figure 7, Item 4**) at the inlet and outlet end of the heater by releasing the two fastener housings (**Figure 7, Item 5**) from the fastener keepers (**Figure 7, Item 6**).
4. Remove the upper housing assembly (**Figure 7, Item 2**) by releasing the remaining fastener housings (**Figure 7, Item 7**) from their corresponding fastener keepers (**Figure 7, Item 8**). Lift and remove the upper housing assembly (**Figure 7, Item 2**). Set the upper housing assembly aside.

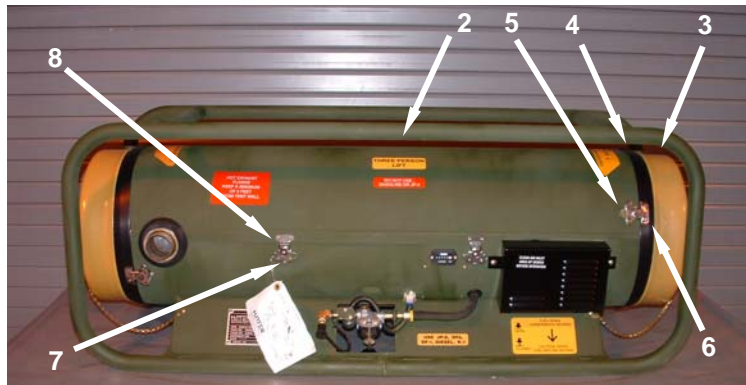

Figure 7. Replace the Burner Assembly Wick.

5. Place a petroleum absorbent mat under the burner assembly.
6. Disconnect the fuel line (**Figure 8, Item 1**) from the burner cover (**Figure 8, Item 2**).

NOTE

Removal of the combustion air hose from the burner cover may provide better access and manipulation of the burner components.

7. Release three clamps (**Figure 8, Item 3**) to open cover (**Figure 8, Item 2**) of burner assembly (**Figure 8, Item 4**), then position clamps behind retainers on cover as shown. Lower the clamps to gently prise the cover from the burner.

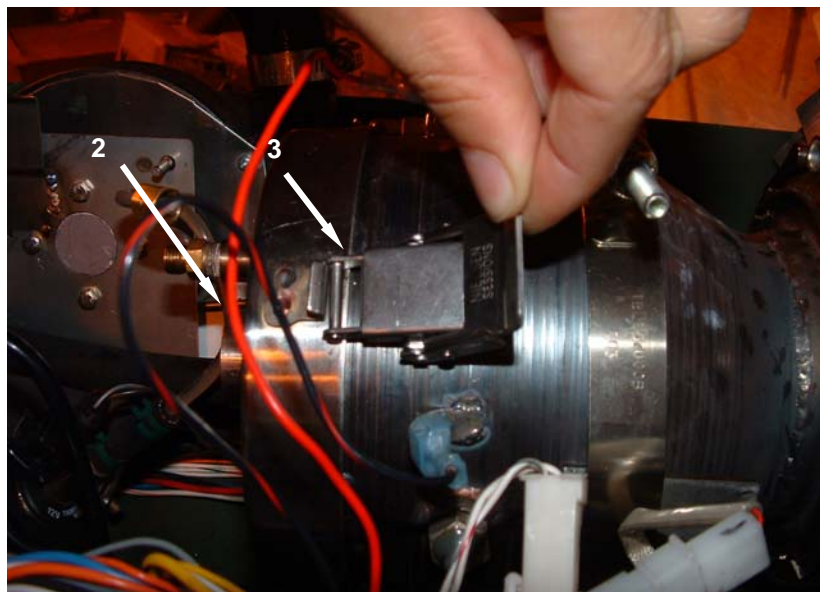
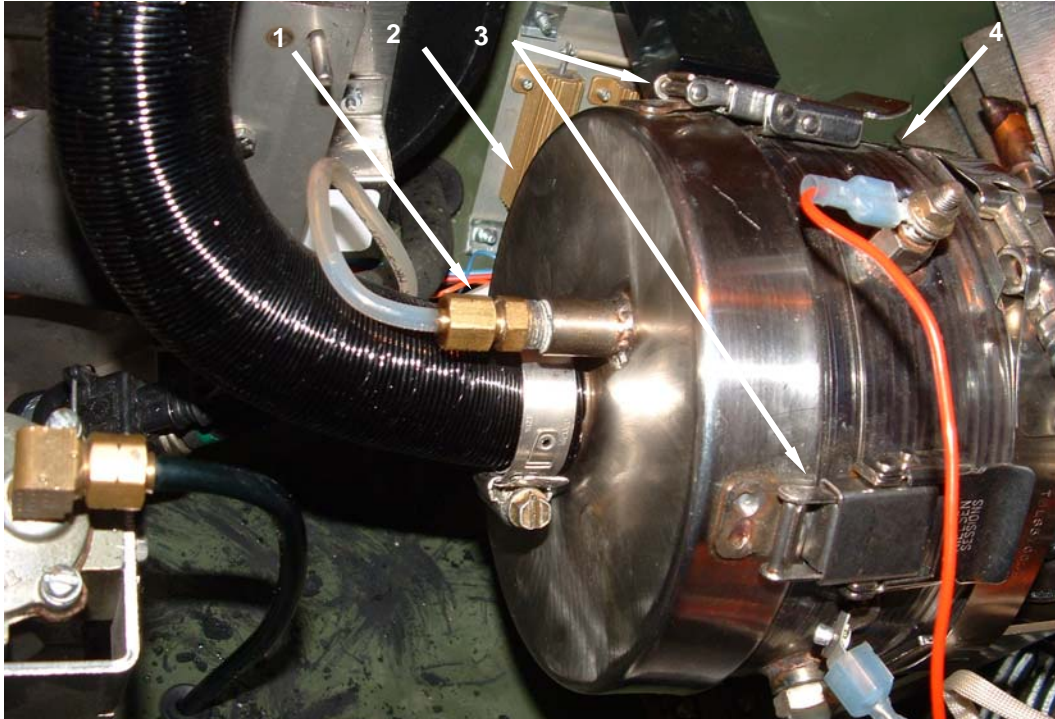

Figure 8. Replace the Burner Assembly Wick - Continued.

CAUTION

Do not attempt to remove the wick unless you intend to replace it. The wick is difficult to remove without damage, and running the SHC-60K with a damaged wick will at best reduce the unit's performance, and may render the SHC-60K inoperable.

NOTE

The installed wrench that is fitted to the SHC-60K may be used, if necessary, to remove or scrape remnants of the wick from the burner cover.

8. Use the wrench to pry the wick (**Figure 9, Item 13**) up and remove it from the burner assembly cover (**Figure 9, Item 10**). Ensure that all of the wick material has been removed.
9. Wipe the burner assembly cover (**Figure 9, Item 10**) clean of loose carbon deposits and remaining wick material.

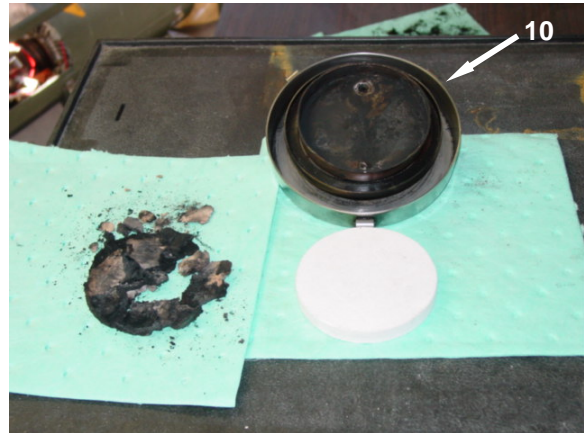

Figure 9. Replace the Burner Assembly Wick - Continued.

NOTE

The wick is a tight fit to the burner assembly cover, and must be installed flush with the rim of the cover. If this cannot be accomplished by hand, notify unit maintenance.

10. Install the replacement wick (**Figure 10, Item 1**) into the burner assembly cover (**Figure 10, Item 2**) with the marked side up, and press in until the wick is flush with the rim of the cover.
11. Ensure the gasket (**Figure 10, Item 3**) is in place, and install the cover (**Figure 10, Item 2**) and secure with latches (**Figure 10, Item 4**). Ensure cover is tight.
12. Reconnect the fuel line (**Figure 10, Item 5**) to the burner assembly cover (**Figure 10, Item 2**).
13. Reinstall the wrench, upper housing, and duct adapter, and operate the SHC-60K IAW WP 0006 00. Monitor for normal operation.

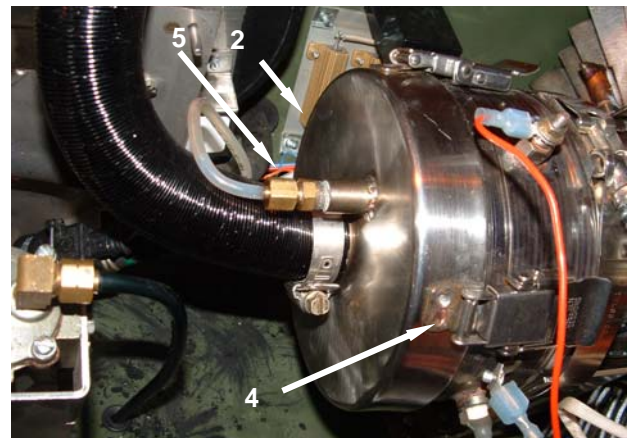
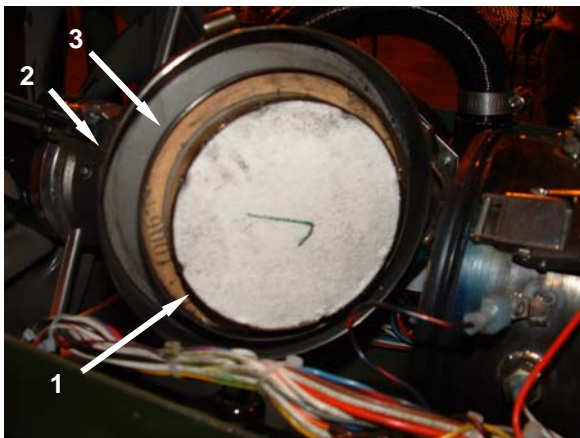
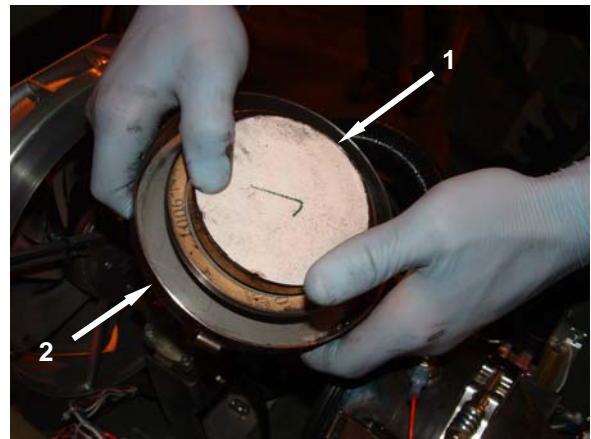
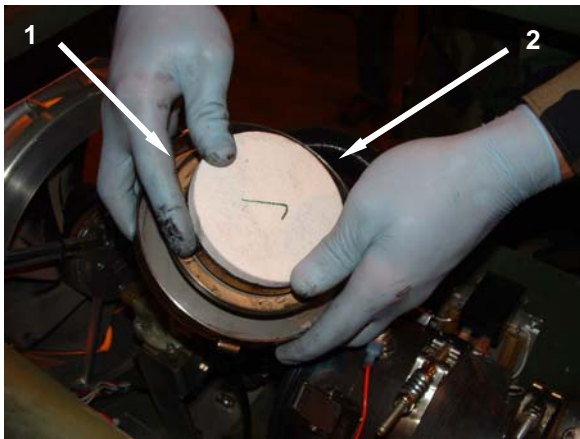

Figure 10. Replace the Burner Assembly Wick - Continued.

END OF WORK PACKAGE

**OPERATOR'S MAINTENANCE
SPACE HEATER, CONVECTIVE 60K BTU (SHC-60K)
NSN 4520-01-520-6477
FLAME SENSOR
REPLACE**

INITIAL SETUP:**Tools**

Wrench (Item 2, WP 0067 00)

Personnel Required

One

Materials/Parts

None required

Equipment Condition

Heater shut down, cool, and all advisory lights off (WP 0006 00)

In-tent controller assembly disconnected from heater (WP 0006 00)

Fuel supply disconnected (WP 0006 00)

REPLACE

WARNING

Be sure to disconnect battery connector before performing any maintenance actions. Failure to do so may cause sparking or short circuits which might cause a fire or damage heater components.

Replace the Flame Sensor

1. Disconnect battery pack connector (**Figure 1, Item 1**) from lower housing assembly.
2. Remove the upper housing assembly (**Figure 1, Item 2**) by first removing the two dust covers (**Figure 1, Item 3**) at the inlet and outlet ends of the heater.
3. Remove the two duct adapters (**Figure 1, Item 4**) at the inlet and outlet end of the heater by releasing the two fastener housings (**Figure 1, Item 5**) from the fastener keepers (**Figure 1, Item 6**).
4. Remove the upper housing assembly (**Figure 1, Item 2**) by releasing the remaining fastener housings (**Figure 1, Item 7**) from their corresponding fastener keepers (**Figure 1, Item 8**). Lift and remove the upper housing assembly (**Figure 1, Item 2**). Set the upper housing assembly aside.
5. Locate the spare flame sensor (**Figure 1, Item 9**) at the breathable air inlet end of the heater.



Figure 1. Replacing Flame Sensor.

6. Disconnect electrical connector from the inoperative flame sensor (**Figure 2, Item 1**).
7. Use the wrench (**Figure 2, Item 2**) supplied with the heater, unscrew flame sensor (**Figure 2, Item 1**) in counterclockwise direction from burner assembly (**Figure 2, Item 3**).
8. Use the wrench (**Figure 2, Item 2**) to remove new flame sensor (**Figure 1, Item 9**) from spare storage area at the breathable air inlet end of the heater.
9. Screw new flame sensor (**Figure 2, Item 1**) in clockwise direction into burner assembly (**Figure 2, Item 3**).
10. Tighten securely with wrench (**Figure 2, Item 2**).
11. Reconnect electrical connector to the flame sensor (**Figure 2, Item 1**).
12. Reinstall upper housing and duct adapters, and operate the SHC-60K IAW WP 0006 00. Monitor for normal operation.

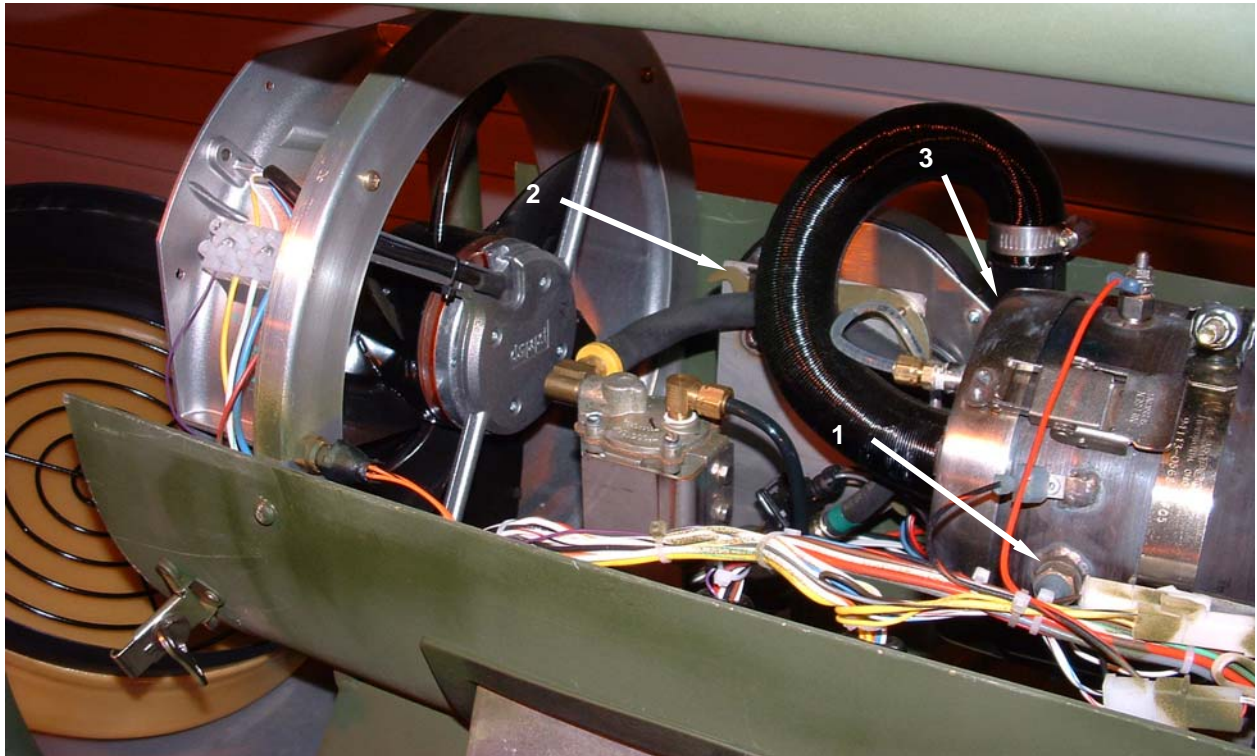

Figure 2. Replacing Flame Sensor – Interior.

END OF WORK PACKAGE

**OPERATOR'S MAINTENANCE
SPACE HEATER, CONVECTIVE 60K BTU (SHC-60K)
NSN 4520-01-520-6477
GLOW PLUG
REPLACE**

INITIAL SETUP:**Tools**

Wrench (Item 2, WP 0067 00)

Personnel Required

One

Materials/Parts

None required

Equipment Condition

Heater shut down, cool, and all advisory lights off (WP 0006 00).

In-tent controller assembly disconnected from heater (WP 0006 00).

Fuel supply disconnected (WP 0006 00).

REPLACE

WARNING

Be sure to disconnect battery connector before performing any maintenance actions. Failure to do so may cause sparking or short circuits which might cause a fire or damage heater components.

Replace the Glow Plug

1. Disconnect battery pack connector (**Figure 1, Item 1**) from lower housing assembly.
2. Remove the upper housing assembly (**Figure 1, Item 2**) by first removing the two dust covers (**Figure 1, Item 3**) at the inlet and outlet ends of the heater.
3. Remove the two duct adapters (**Figure 1, Item 4**) at the inlet and outlet end of the heater by releasing the two fastener housings (**Figure 1, Item 5**) from the fastener keepers (**Figure 1, Item 6**).
4. Remove the upper housing assembly (**Figure 1, Item 2**) by releasing the remaining fastener housings (**Figure 1, Item 7**) from their corresponding fastener keepers (**Figure 1, Item 8**). Lift and remove the upper housing assembly, and set the upper housing assembly aside.
5. Locate the spare glow plug (**Figure 1, Item 9**) at the breathable air inlet end of the heater.
6. Disconnect electrical lead (**Figure 1, Item 10**) from the inoperative glow plug (**Figure 1, Item 11**).
7. Use the wrench (**Figure 1, Item 12**) secured to the combustion air inlet assembly, loosen and remove glow plug (**Figure 1, Item 11**) from burner assembly (**Figure 1, Item 13**) by turning in a counterclockwise direction.
8. Use the wrench (**Figure 1, Item 12**) to remove the spare glow plug (**Figure 1, Item 9**) from the breathable air inlet end of the heater. Screw the replacement glow plug in a clockwise direction into burner assembly (**Figure 1, Item 13**) and reconnect electrical lead (**Figure 1, Item 10**).

- 9. Reinstall wrench, upper housing, and duct adapters, and operate the SHC-60K IAW WP 0006 00. Monitor for normal operation.

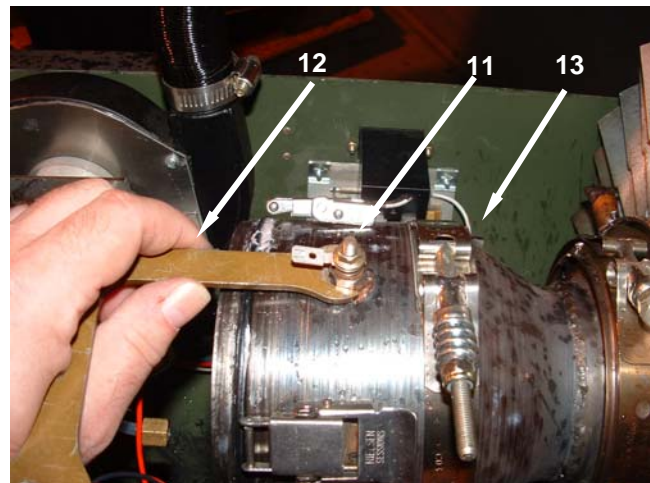
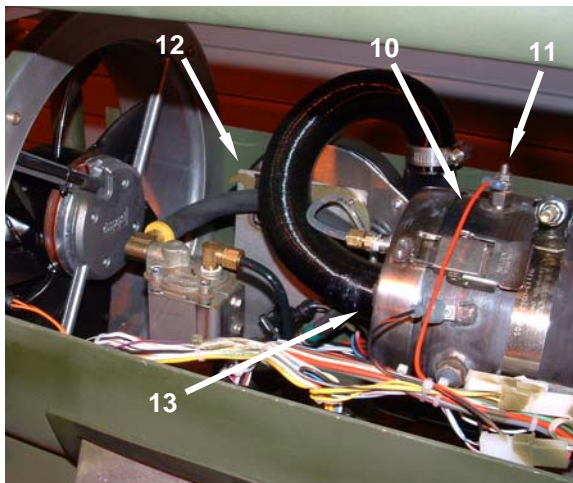
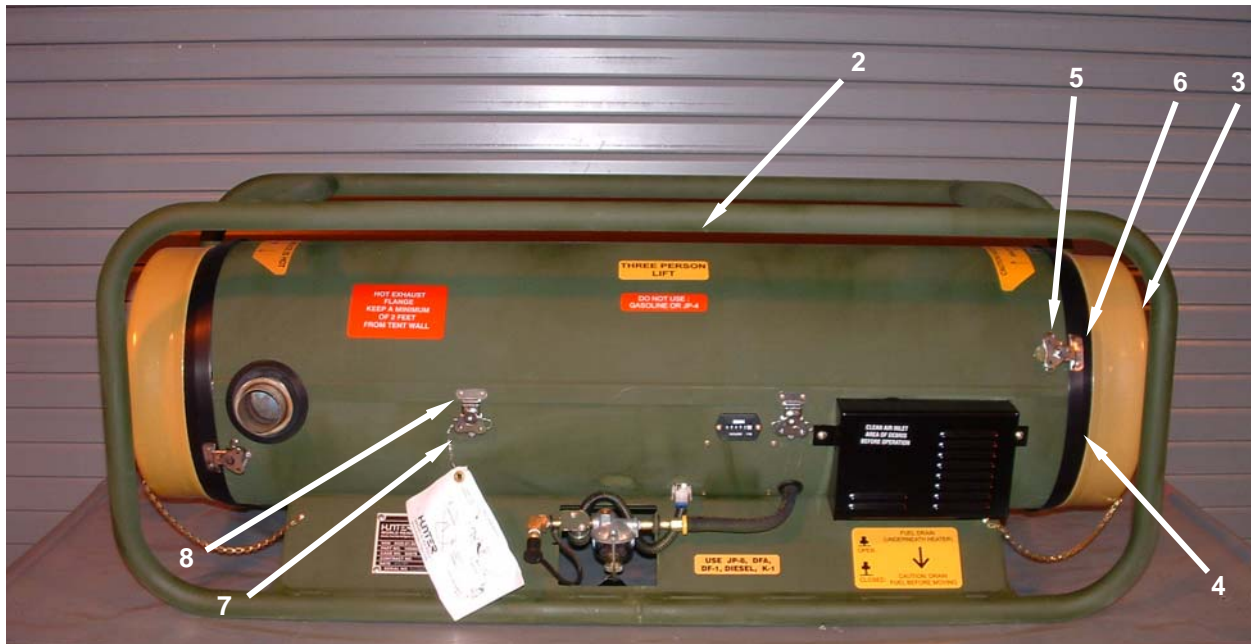
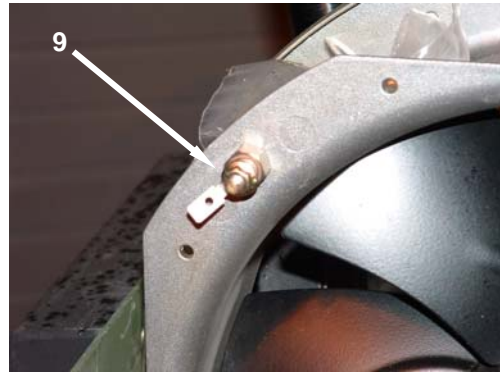
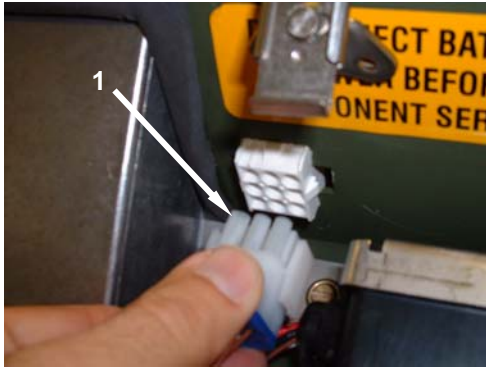

Figure 1. Replace Glow Plug.

END OF WORK PACKAGE

**OPERATOR'S MAINTENANCE
SPACE HEATER, CONVECTIVE 60K BTU (SHC-60K)
NSN 4520-01-520-6477
DUCT ADAPTER
REPLACE**

INITIAL SETUP:**Tools**

None required

Personnel Required

One

Materials/Parts

None required

Equipment Condition

Heater shut down, cool, and all advisory lights off (WP 0006 00).

Dust covers removed (WP 0005 00).

REPLACE**Replace a Duct Adapter**

1. To remove the duct adapter (**Figure 1, Item 1**), lift and rotate the fastener housing (**Figure 1, Item 2**), releasing it from the fastener keeper (**Figure 1, Item 3**) on the upper housing assembly (**Figure 1, Item 4**).
2. Repeat for the second fastener housing and keeper on the opposite side of the duct adapter (**Figure 1, Item 1**).
3. Pull the duct adapter (**Figure 1, Item 1**) from the heater body (**Figure 1, Item 5**).
4. To install a new duct adapter (**Figure 1, Item 1**), align it over the end of the heater body (**Figure 1, Item 5**) and press it into position.
5. Engage the fastener housings and keepers (**Figure 1, Items 2 and 3**) on both sides of the duct adapter (**Figure 1, Item 1**) and secure in place.



Figure 1. Duct Adapter.

END OF WORK PACKAGE

**UNIT MAINTENANCE
SPACE HEATER, CONVECTIVE 60K BTU (SHC-60K)
NSN 4520-01-520-6477
UNIT MAINTENANCE INTRODUCTION**

GENERAL

The procedures in this section have been arranged in order in which the items appear in the Unit (O) Maintenance level column on the Maintenance Allocation Chart (MAC) which is provided in WP 0067 00. Step by step procedures have been provided for all actions authorized to be performed by the Unit in Chapter 4.



WARNING

Be sure to disconnect battery connector before performing any maintenance procedures. Failure to do so may cause sparking or short circuits which might cause a fire or damage heater components.

WIRING

General

Preferred repair methods consist of replacing wires, terminals, connectors, etc., rather than splicing wires, bending ends to form terminals, and other makeshift procedures, although the latter may be appropriate for emergency field repairs.

Soldering Connections

Wire connections must be made mechanically sound before they are soldered. Solder alone does not provide sufficient strength to prevent breakage. Joining surfaces of connections to be soldered must be clean and bright. If a separate flux is used, it should be rosin base flux and should be brushed onto the joint before soldering. If a flux-core solder is used, it should be a rosin core electrical solder. If solid solder is used, it should be a lead-tin solder. Wires should always be heated to the point at which the solder will melt completely and flow into all parts of the joint. Excessive build up of solder "gobs" on the joint should be avoided or removed.

Insulating Joints

The preferred method of insulating electrical joints is by the use of heat-shrink tubing. To apply, cut a piece of heat-shrink tubing of suitable diameter to a one-inch length for covering joints at terminals or connectors, or to a length about 1/2 inch (1.3 cm) longer than the joint to be insulated, and slide the tubing over the wire before making the joint. After the joint is made, slide the tubing so that it covers the joint, and shrink in place with moderate heat.

Splicing Wires

To repair broken or cut wires that are otherwise sound, the mating ends can be stripped and spliced. A commercial butt splice can be crimped onto the ends to join them, or a "Western Union" wire splice can be made. The latter is made by stripping 1/4-1/2 inch (6.5-12.7 mm) of insulation from the wire ends, holding the ends parallel and facing opposite directions, then twisting each end around the other wire at least three turns. Solder and apply insulation as described above.

Crimping Terminals

To install a terminal on the end of a wire, strip 1/4-1/2 inch (6.5 -12.7 mm) of insulation from the end of the wire, apply a one-inch piece of heat-shrinking tubing (if the terminals are of the uninsulated type) and insert wire end into the shank of the terminal. Crimp the shank, and install heatshrink tubing, if necessary.

CLEANING AND INSPECTION OF ANTIFRICTION BEARINGS

Refer to TM 9-214, Inspection, Care, and Maintenance of Antifriction Bearings.

CLEANING AND INSPECTION OF MECHANICAL PARTS



WARNING

Compressed air may propel parts, shavings, dirt particles, and liquid solvents at high speed, and may cause serious skin and eye injury if necessary precautions are not observed. Always wear protective clothing when using compressed air.



WARNING

Isopropyl alcohol is flammable, toxic, and hazardous to eyes, skin, and respiratory tract. Impervious hand and eye protection is required. Avoid unprotected, repeated, or prolonged contact. If contact with eyes is made, immediately flush with clean water seek medical attention. Use only in well ventilated areas. Keep away from open flames or other sources of ignition.

Use compressed air to blow away loose particles from heater components, and to dry components that have been cleaned with water or isopropyl alcohol. Compressed air used for cleaning purposes will not exceed 30 psi (kPa). Use only with effective personal protective equipment – exposed skin may be subject to injury from flying particles or poisoning from liquid solvents.



WARNING

JP-8 and all approved fuels for the SHC-60K are highly flammable and should never be used in proximity with any potential ignition source. Applying compressed air to fuel may atomize the fuel, creating an explosive fuel air mixture, and may also inject fuel into exposed skin.

Fuel system components should be cleaned in clean fuel and wiped dry with disposable lint-free toweling. Do not use water or isopropyl alcohol on any fuel system components. Do not use compressed air to dry fuel from any components.

Fibrous or rubber parts which are not in contact with fuel can generally be cleaned with warm, soapy water and dried with compressed air.

Inspect metal parts for cracks, breaks, bends, worn edges, and rough bearing surfaces. Damage that alters the part or its function is cause for replacement of that part.

GENERAL REPAIR

Repair the SHC-60K to normal operating condition by replacing or repairing a defective component and/or by needed adjustments.

Cleaning and lubrication is sometimes all that is needed to return an item to operating condition.

Remove and replace only those items necessary to make repairs. After replacing the defective components, ensure that the SHC operates correctly.

To paint metal, sand bare metal areas with sandpaper and refinish with primer and olive drab paint. Refer to TM 43-0139 for proper painting instructions. Allow paint to dry between coats.

END OF WORK PACKAGE

**UNIT MAINTENANCE
SPACE HEATER, CONVECTIVE 60K BTU (SHC-60K)
NSN 4520-01-520-6477
IN-TENT CONTROLLER ASSEMBLY
INSPECT, TEST, REPLACE**

INITIAL SETUP:**Tools**

Tool Kit, General Mechanic's (Item 1, WP 0067 00)

Personnel Required

One

Materials/Parts

None Required

Equipment Condition

Heater shut down, cool, and all advisory lights off (WP 0006 00).

Battery disconnected (WP 0043 00)

INSPECT**Inspect the In-Tent Controller**

1. Remove cable and inspect the In-tent Controller Assembly connector (**Figure 1, Item 1**) for cracks, dents to the outer collar, dirt in the contacts, or any other damage that would prevent the connector from making a good electrical connection with the in-tent controller cable assembly (**Figure 1, Item 2**).
2. Inspect the ON-OFF switch (**Figure 1, Item 3**) and LOWER-HIGHER control (**Figure 1, Item 4**) to ensure proper operation.
3. Ensure that each of the advisory lights (**Figure 1, Item 5**) are not damaged.
4. Ensure that all informational labels (**Figure 1, Item 6 and Figure 1, Item 7**) are present and legible.

TEST**Test the In-Tent Controller**

Using a multimeter set to read resistance, perform a short circuit test across all terminals (**Figure 1, Item 8**) of the connector (**Figure 1, Item 1**). For example, pin A to pin B, A to C, A to D, etc. Followed by B to A, B to C, B to D, etc. There should not be shorts across any of the pins. If shorts exist, replace the in-tent controller assembly.

REPLACE**Replace the In-Tent Controller**

1. To replace the in-tent controller assembly (**Figure 1, Item 1**), unscrew the outer collar (**Figure 1, Item 9**) of the in-tent controller assembly cable (**Figure 1, Item 2**) and disconnect cable from in-tent controller assembly.
2. Connect in-tent controller cable (**Figure 1, Item 2**) to new in-tent controller assembly (**Figure 1, Item 1**).
3. Tighten outer collar (**Figure 1, Item 9**) of in-tent controller assembly cable (**Figure 1, Item 2**) securely.

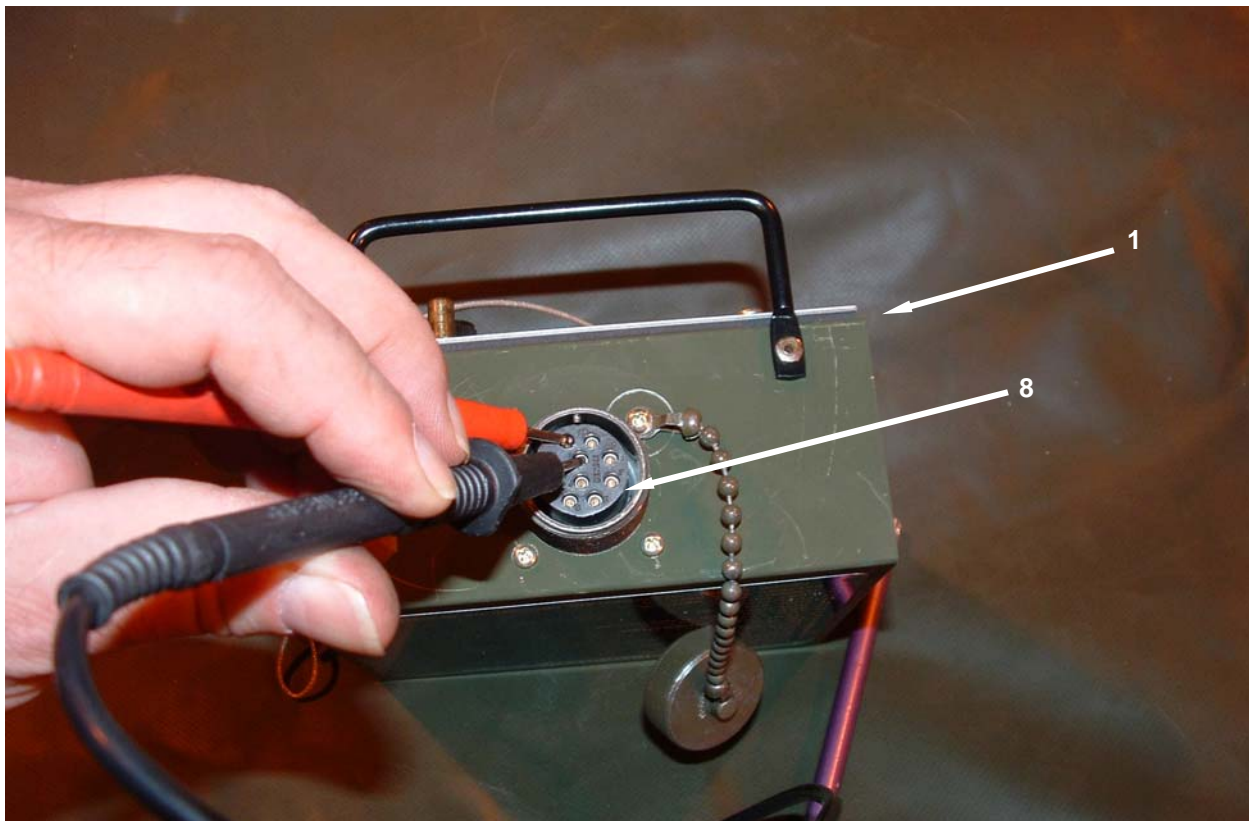
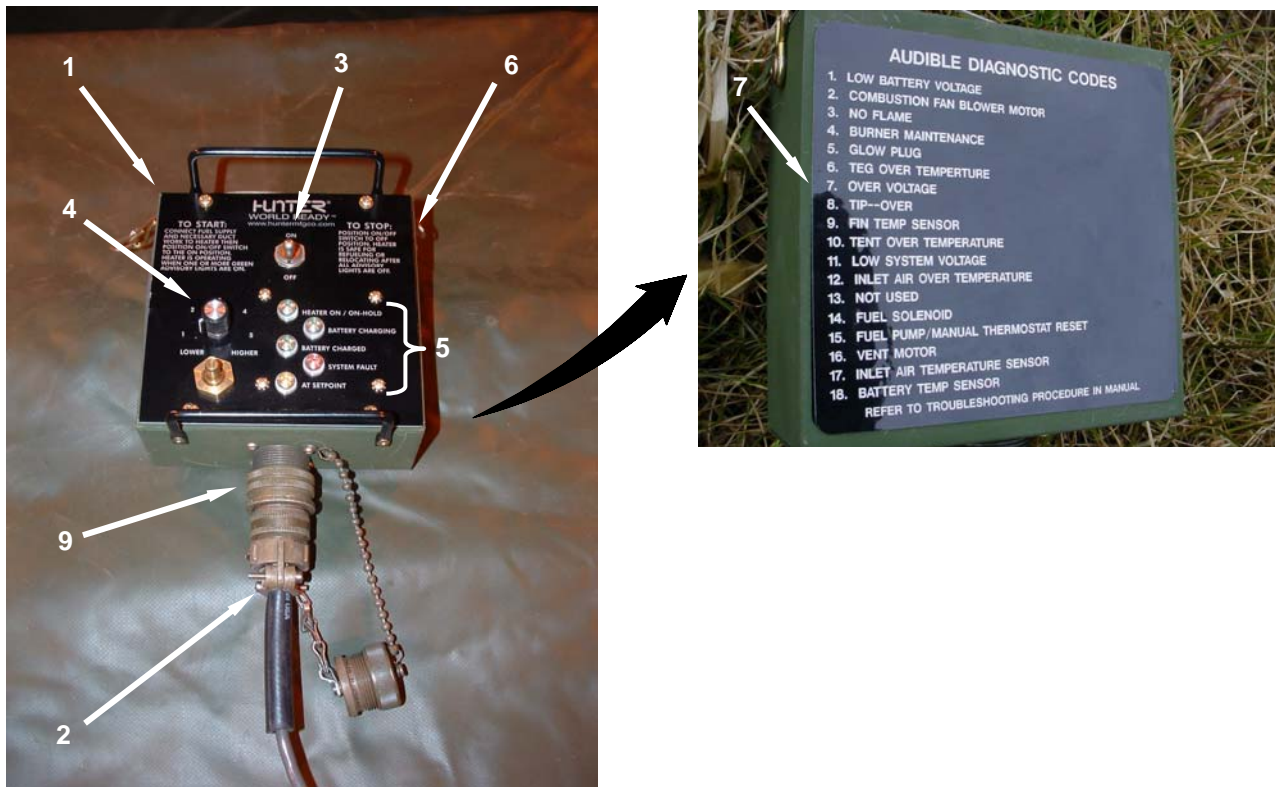

Figure 1. In-tent Controller Assembly.

END OF WORK PACKAGE

**UNIT MAINTENANCE
SPACE HEATER, CONVECTIVE 60K BTU (SHC-60K)
NSN 4520-01-520-6477
IN-TENT CONTROLLER CABLE ASSEMBLY
INSPECT, TEST, REPLACE**

INITIAL SETUP:

Tools

Tool Kit, General Mechanic's (Item 1, WP 0067 00)

Personnel Required

Two

Materials/Parts

None required

Equipment Condition

Heater shut down and cool (WP 0006 00)
In-tent controller assembly cable disconnected from heater and in-tent controller assembly connector.
Battery disconnected (WP 0043 00)

INSPECT

Inspect the In-Tent Controller Cable Assembly

1. Remove cable from in-tent controller and heater control box.
2. Inspect the in-tent controller cable assembly connectors (**Figure 1, Item 1**) for cracks, dents to the outer collar, dirt in the contacts, or any other damage that would prevent the connector (**Figure 1, Item 1**) from making a good electrical connection with the heater control box connector (**Figure 1, Item 2**) or the in-tent controller assembly connector (**Figure 1, Item 3**).

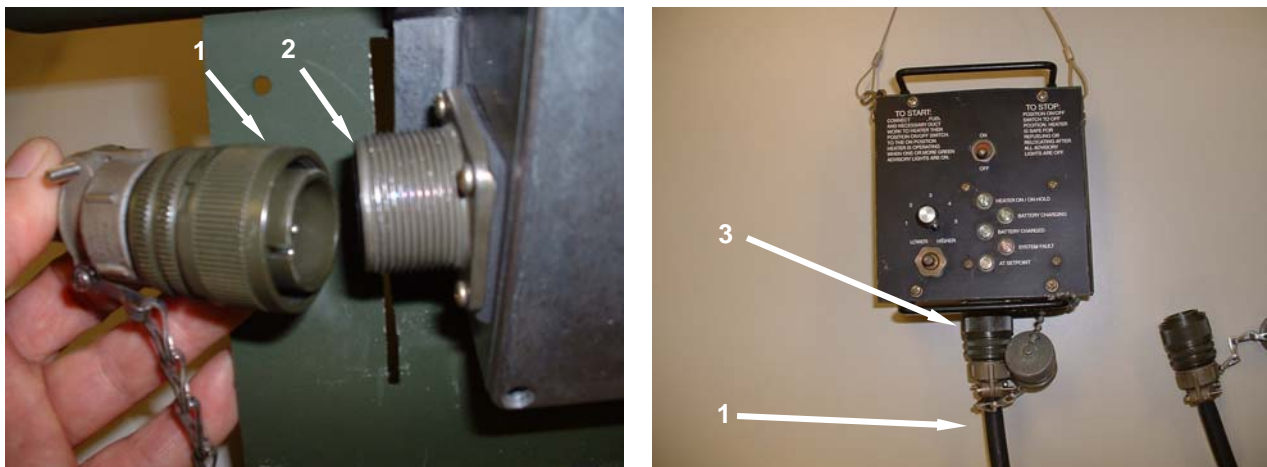

Figure 1. Inspect the In-tent Controller Cable Assembly.

NOTE

For the next two steps two people are recommended.

TEST**Test the In-Tent Controller Cable Assembly**

1. Using a multimeter, perform a continuity check from pin A at one end of the cable (**Figure 2, Item 1**) to pin A at opposite end of cable (**Figure 2, Item 2**). Repeat for all pins. Ensure that there is continuity through the cable.
2. Using a multimeter, perform a short circuit test across all terminals of the connector at one end of cable (**Figure 2, Item 1**). For example, test from pin A to pin B, A to C, A to D, etc. Followed by B to A, B to C, B to D, etc. There should not be shorts across any of the pins. If shorts exist, replace the in-tent controller assembly cable.
3. If there is a lack of continuity through the cable (**Figure 2, Item 3**) or shorts within either of the connectors, replace the in-tent controller cable assembly.

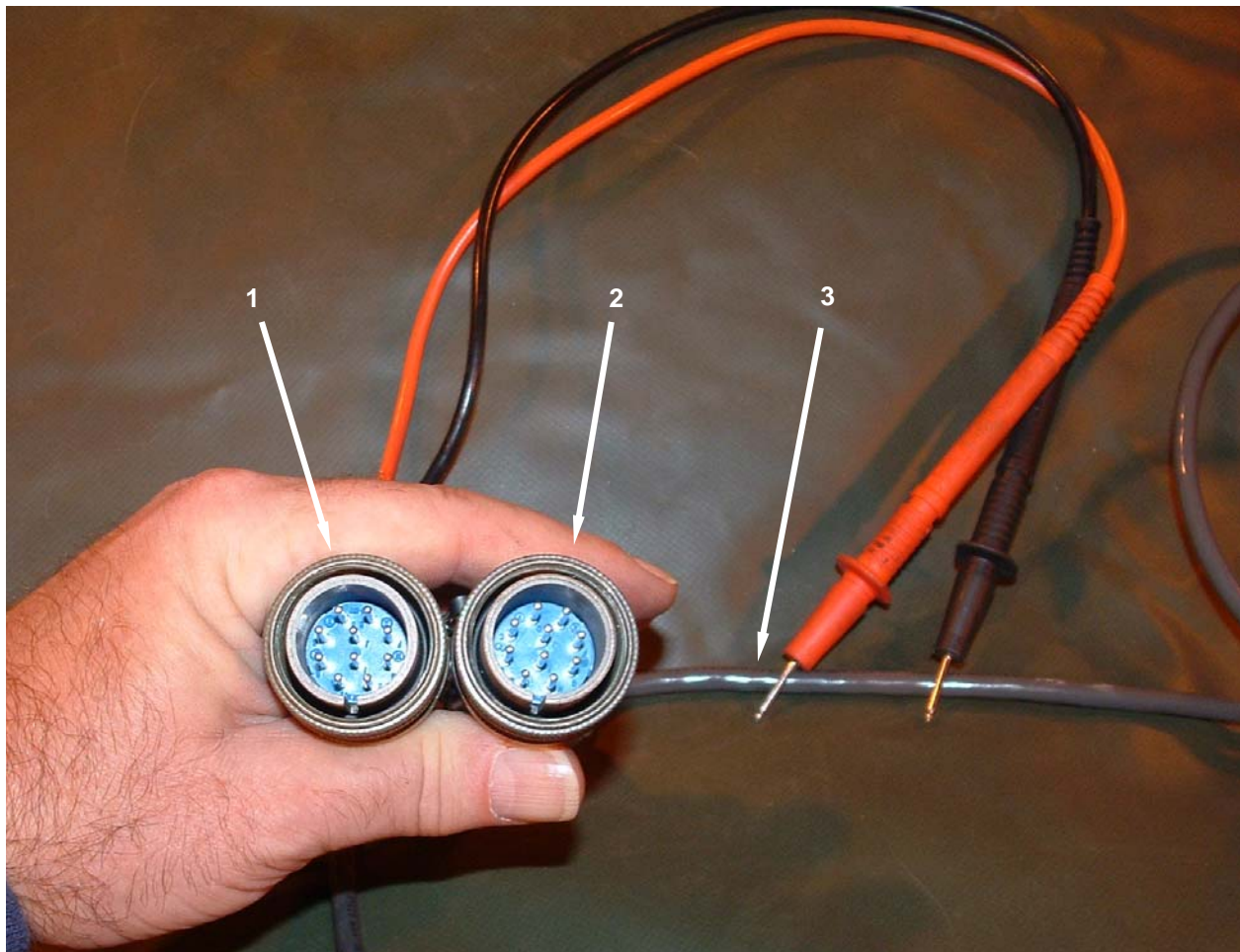

Figure 2. Test the In-Tent Controller Cable Assembly.

REPLACE**Replace the In-Tent Controller Cable Assembly**

1. Ensure that the in-tent controller cable assembly (**Figure 3, Item 1**) has been completely disconnected from the in-tent controller assembly (**Figure 3, Item 2**) and the heater (**Figure 3, Item 3**).
2. Connect new cable (**Figure 3, Item 1**) to the heater and to the in-tent controller assembly (**Figure 3, Item 2**). Secure connectors at both ends of in-tent controller assembly cable.

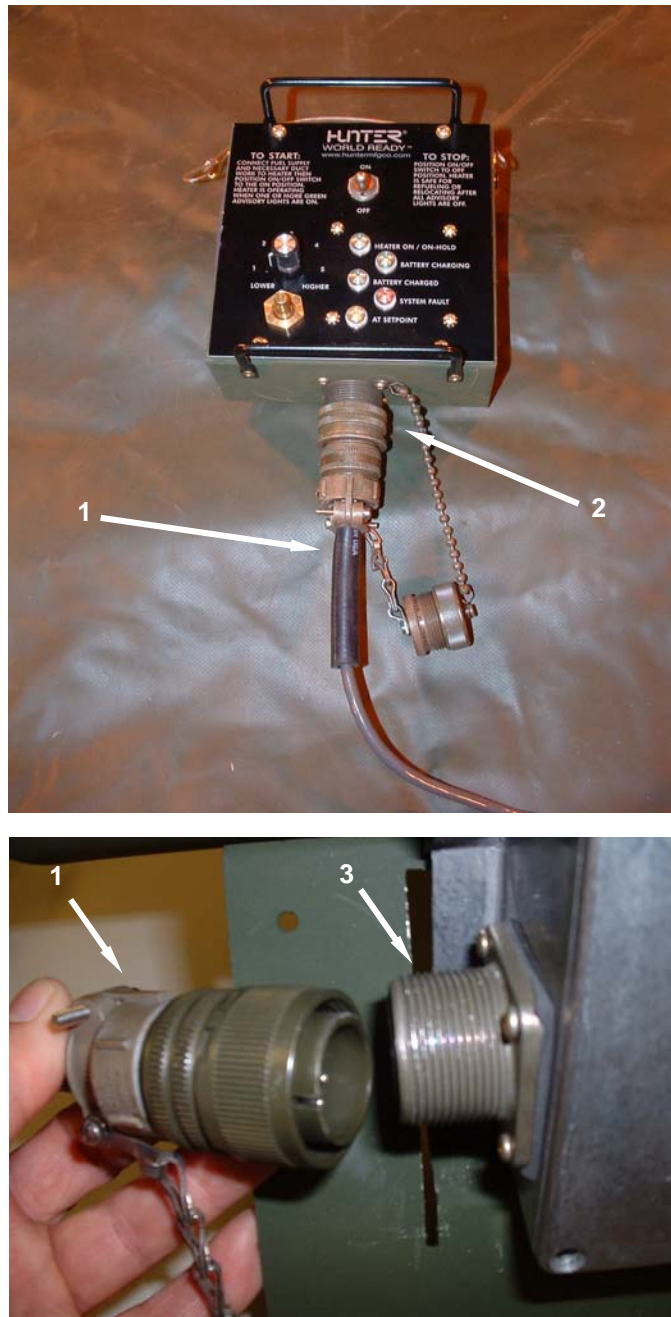

Figure 3. Replace the In-Tent Controller Cable Assembly.

END OF WORK PACKAGE

**UNIT MAINTENANCE
SPACE HEATER, CONVECTIVE 60K BTU (SHC-60K)
NSN 4520-01-520-6477
BATTERY PACK ASSEMBLY
INSPECT, TEST, SERVICE, REPLACE**

INITIAL SETUP:**Tools**

Tool Kit, General Mechanic's (Item 1,
WP 0067 00)

Personnel Required

One

Materials/Parts

None required

Equipment Condition

Heater shut down and cool, all advisory lights
off (WP 0006 00).
In-tent controller assembly disconnected from
heater (WP 0006 00).

INSPECT**Inspect Battery Pack Assembly****WARNING**

Be sure to disconnect battery connector before performing any maintenance actions. Failure to do so may cause sparking or short circuits which might cause a fire or damage heater components.

Avoid exposure to leaking electrolyte, which can cause severe irritation and/or damage to the skin, mucous membrane or eyes. Always wear skin and eye protection when handling a leaking battery pack.

1. Inspect battery pack (**Figure 1, Item 1**) for signs of physical damage or chemical leakage.
2. Inspect battery pack electrical connector (**Figure 1, Item 2**). Ensure that connector is not cracked or damaged in any way. Ensure that all wires (**Figure 1, Item 3**) leading from battery pack (**Figure 1, Item 1**) to connector housing are free of cuts, abrasions, or any other damage that would expose bare wire.
3. Inspect the two fuse holders (**Figure 1, Item 4**) on the side of the battery pack (**Figure 1, Item 1**) and ensure that there are no cracks or other damage that would prevent the fuse holders from securing the fuse and maintaining proper electrical contact.

**WARNING**

Avoid exposure to leaking electrolyte, which can cause severe irritation and/or damage to the skin, mucous membrane or eyes. Always wear skin and eye protection when handling a leaking battery pack.

4. Ensure that there are no cracks, cuts, or other damage to the outer casing of the battery pack (**Figure 1, Item 1**).

NOTE

The battery pack must be handled and disposed of IAW the MSDS information given in WP 0001 00.

5. If there is any damage to the connector (**Figure 1, Item 2**), fuse holders (**Figure 1, Item 4**), or wiring (**Figure 1, Item 3**), the battery pack should be replaced.

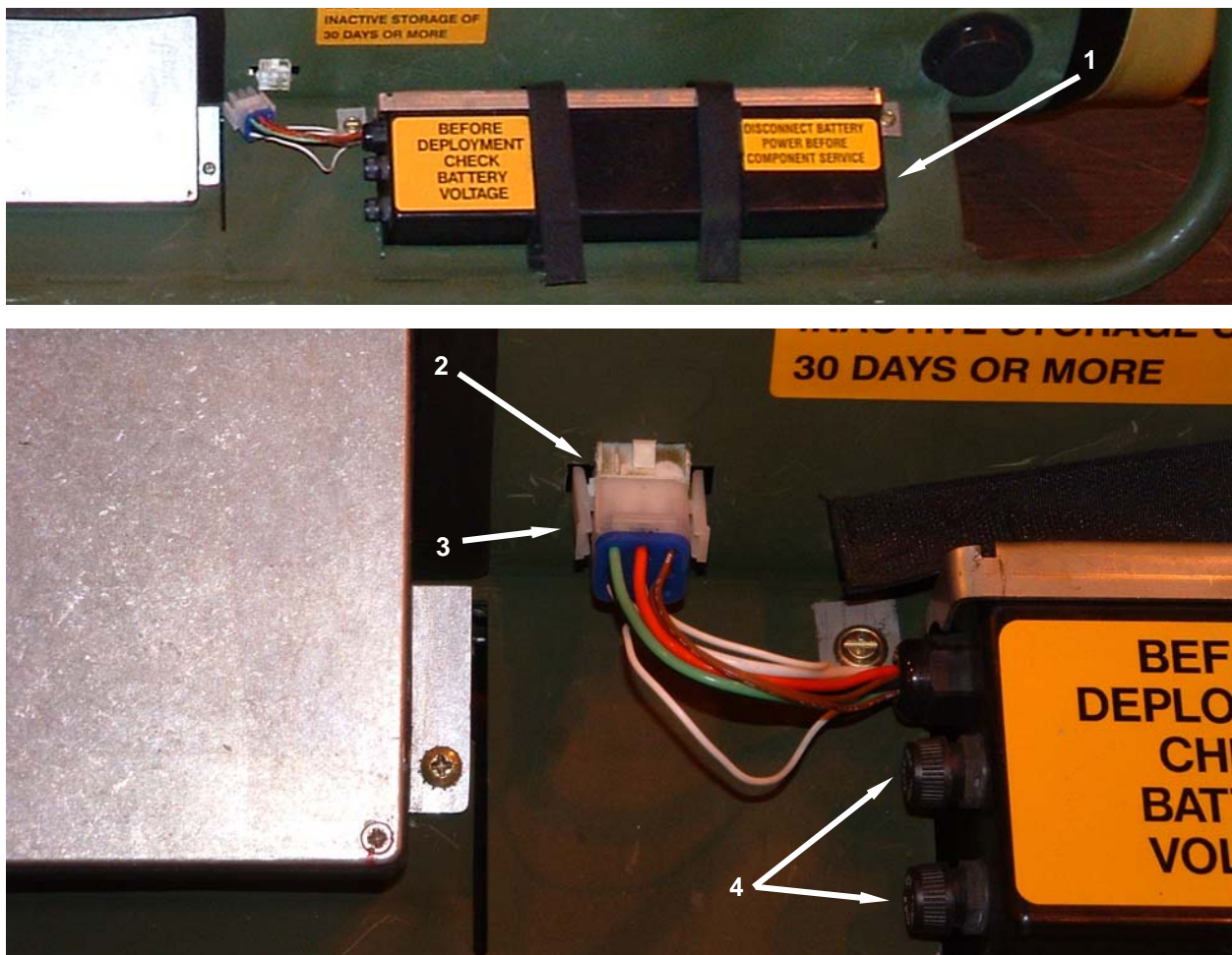

Figure 1. Inspect Battery Pack Assembly.

TEST

Test Battery Pack Assembly

1. Before replacing the battery pack, ensure that the two fuses (**Figure 2, Item 1**) are in good electrical working order by removing them from the fuse holders (**Figure 2, Item 2**) on the left side of the battery pack (**Figure 2, Item 3**) and testing for continuity with a multimeter. Continuity through the fuse ensures that it is in good electrical working order.
2. If there is no continuity through the fuse, replace it with a known good fuse from the on-board spare parts (**Figure 2, Item 4**) located at the inlet end (**Figure 2, Item 5**) of the heater.
3. If the fuses are both in good electrical working order and the battery pack is not supplying power, check the battery voltage without a load. There are two battery circuits in the battery pack. Use a voltmeter to check the voltage on one battery circuit in the pack by inserting the voltmeter probes into the red and black wire pockets in the battery connector (**Figure 2, Item 6**). It should read 12.5 to 13.0 volts. Check the other battery circuit in the pack by inserting the voltmeter probes in the green and white wire pockets in the battery connector (**Figure 2, Item 6**). It should also read 12.5 to 13.0 volts. If either of the two battery circuits in the pack do not read in the 12.5 to 13.0 volt range, recharge the battery as detailed below.
4. If the fuses are both in good electrical working order and the battery pack is not supplying power to the heater, attempt to recharge IAW service procedures detailed on the following page.

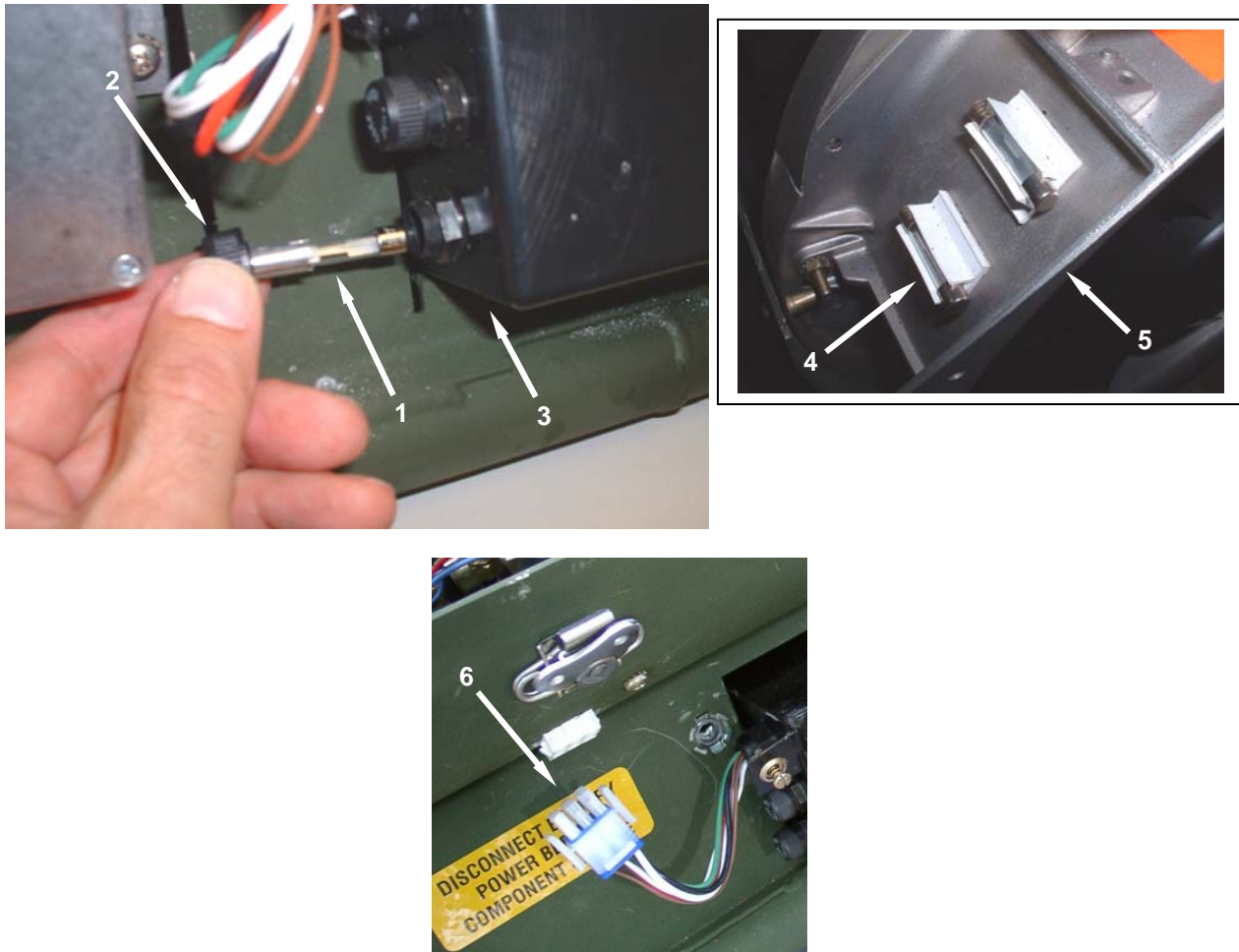

Figure 2. Test Battery Pack Assembly.

SERVICE

Charging the Battery Using a NATO Charging System

Under normal conditions the SHC-60K is responsible for recharging the on-board battery pack. If necessary, a NATO charging system cable (**Figure 3, Item 1**) with integral transformer may be used to charge the battery on the SHC-60K.

NOTE

It may be necessary to remove the battery from the heater in order to use the NATO charging system. If so, notify Unit maintenance.

1. To charge the battery (**Figure 4, Item 1**) using a NATO charging system (**Figure 4, Item 2**), disconnect the battery connector (**Figure 4, Item 3**) from the heater and engage the connector (**Figure 4, Item 4**) on the end of the NATO charging adapter with the connector on the battery pack.
2. Plug the slave connection (**Figure 4, Item 5**) into the matching receptacle on the vehicle or equipment used to provide electrical power.
3. Verify that the charging unit green power light (**Figure 4, Item 6**) is on, indicating that the NATO charging system (**Figure 4, Item 2**) is operating correctly.
4. Depending upon the battery temperature, recharge time for the battery (**Figure 4, Item 1**) will be approximately 30 minutes. The battery will take longer to recharge in cold weather conditions.
5. When the battery is fully charged, disconnect the NATO charging system cable (**Figure 4, Item 2**), stow the NATO charging system cable in the heater accessory bag, and operate IAW WP 0006 00.
6. If the battery will not take a charge, replace the battery.



Figure 3. NATO Charger.



Figure 4. Connecting the NATO Charger.

Charging the Battery with an External Charger

A battery charging adapter (**Figure 5, Item 1**) has been supplied with the heater to permit the connection of a commercial battery charger to the battery pack. If this charging method is necessary, notify unit maintenance.



WARNING

Do not allow the metal terminals of the battery charging adapter to come in contact with the metallic portion of the heater. Sparking and ignition of fuel may occur resulting in fire or explosion. Failure to observe this precaution may result in serious injury or death to personnel.

CAUTION

Do not permit the battery charger terminals to come in contact with the metal casing of the heater as this may cause damage to the battery pack assembly.

NOTE

No grounding is necessary when using the battery charging adapter.

1. To charge the battery (**Figure 5, Item 2**) with a commercial 115 VAC to 12 VDC battery charger (**Figure 5, Item 3**), disconnect the battery connector (**Figure 5, Item 4**) from the heater and engage the connector on the end of the battery charging adapter (**Figure 5, Item 1**) with the connector on the battery pack.
2. Connect the positive (+) lead of the charger to the red (+) wire (**Figure 5, Item 5**) of the battery charging adapter (**Figure 5, Item 1**) and the negative (-) lead of the charger to the black (-) wire (**Figure 5, Item 6**) of the battery charging adapter.
3. Once the charger (**Figure 5, Item 3**) is connected to the battery charging adapter (**Figure 5, Item 1**) properly, plug the battery charger into an electrical receptacle, and turn on the power to the charger.
4. Depending upon the battery temperature, recharge time for the battery will be approximately 30 minutes. The battery will take longer to recharge in cold weather conditions.
5. When the battery is fully charged, disconnect the battery charger from the adapter, stow the adapter in the heater accessory bag, and operate IAW WP 0006 00.

NOTE

The battery pack must be handled and disposed of IAW the MSDS information given in WP 0001 00.

6. If the battery will not take a charge, replace the battery.

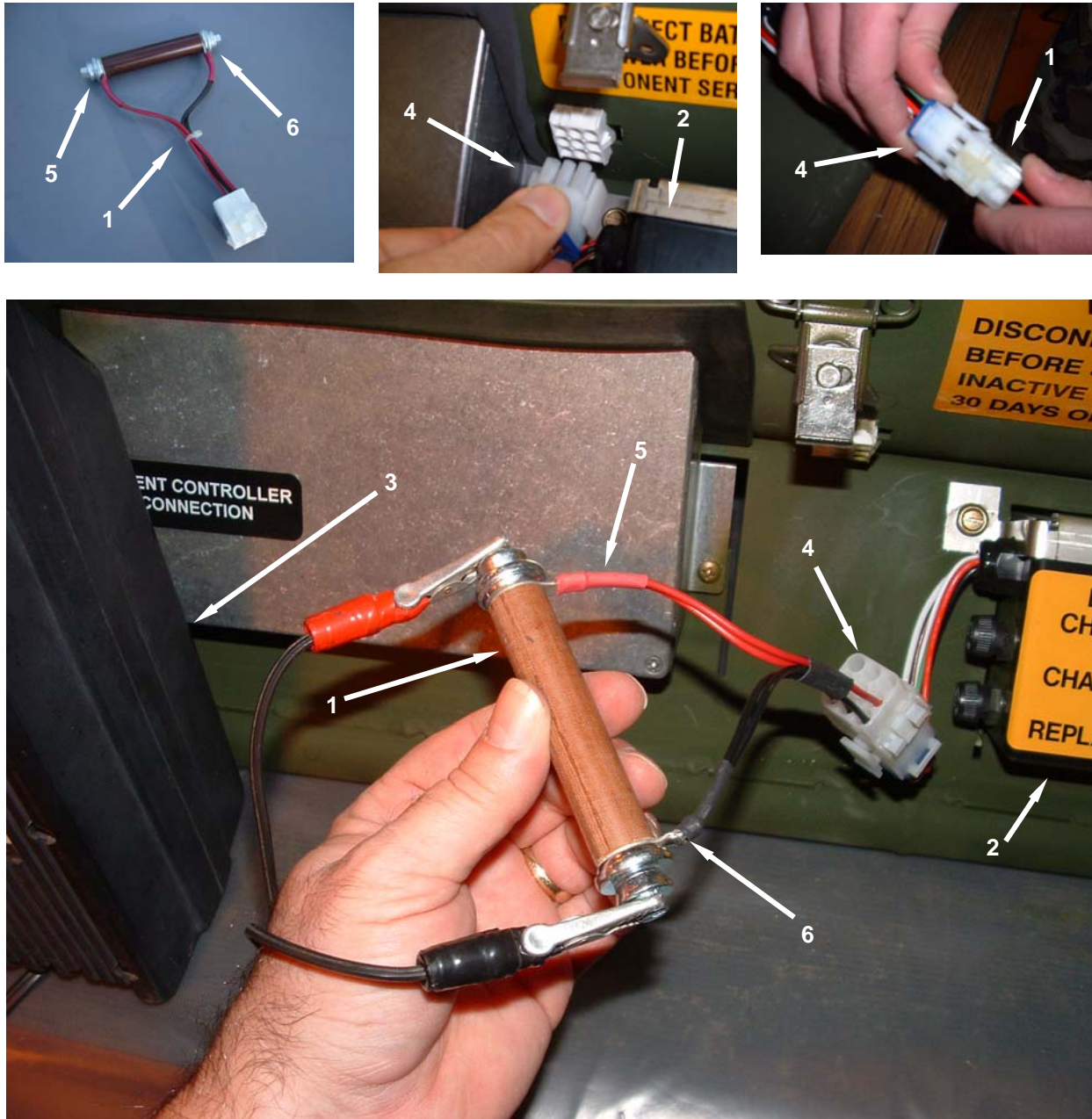

Figure 5. Charging the Battery with an External Charger.

REPLACE**Replace Battery Pack Assembly**

1. Before replacing the battery pack, an attempt should be made to recharge the battery pack in accordance with the Service section of this work package. If the battery is incapable of retaining a charge and will not start the heater, it should be replaced.
2. To remove the battery pack (**Figure 6, Item 1**), first release the hook and pile retaining straps, and then remove the battery pack retainer (**Figure 6, Item 2**) by removing the two screws (**Figure 6, Item 3**) on either side of the retainer. Remove the retainer.
3. Disconnect the battery pack connector (**Figure 6, Item 4**) by unplugging from portion of connector mounted in side of heater.
4. Slide the battery pack (**Figure 6, Item 1**) out of the recess (**Figure 6, Item 5**) on the side of the heater.

NOTE

The battery pack must be handled and disposed of IAW the MSDS information given in WP 0001 00.

5. Dispose of the battery pack (**Figure 6, Item 1**) in accordance with appropriate military and/or local regulations as described in TB 43-0134.
6. Install a new battery pack (**Figure 6, Item 1**) into the recess (**Figure 6, Item 5**) on the side of the heater. Be sure to orient the connector (**Figure 6, Item 4**) on the side of the battery pack so that it aligns with the connector (**Figure 6, Item 6**) installed on the side of the heater. Engage both halves of the connector and ensure that they are firmly mated.
7. Install the retainer (**Figure 6, Item 2**) in place over the battery pack (**Figure 6, Item 1**). Install and secure the two screws (**Figure 6, Item 3**) that secure the retainer. Secure the hook and pile retaining straps in place.

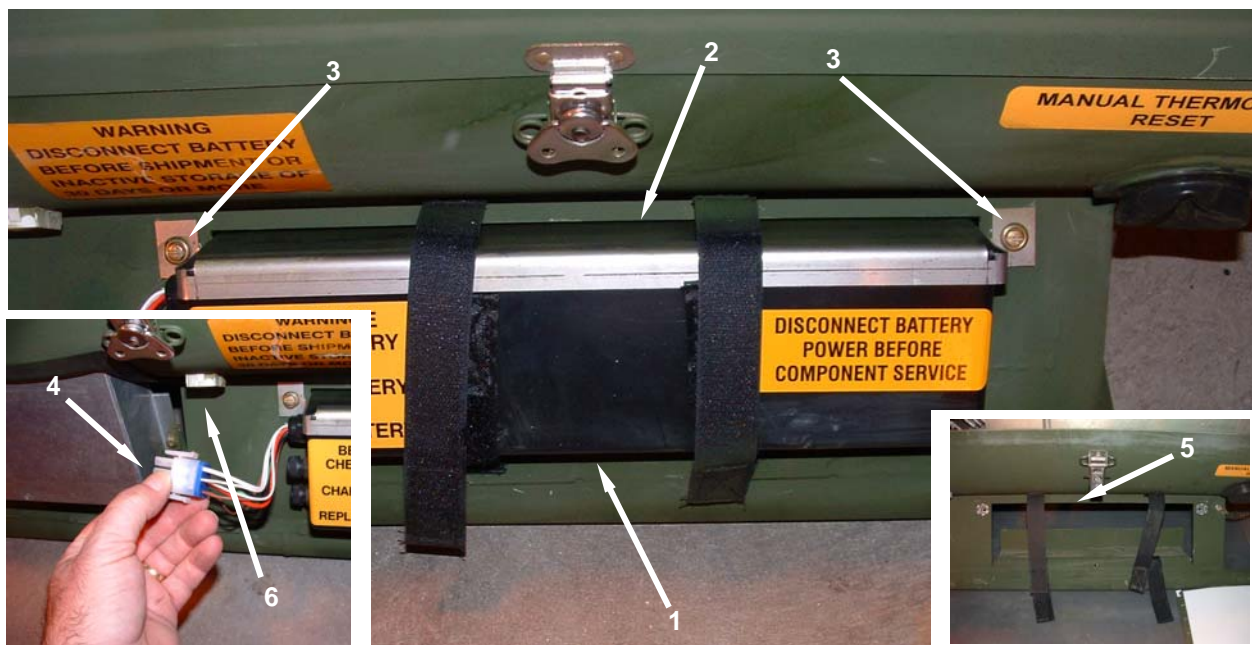

Figure 6. Replace Battery Pack Assembly.

END OF WORK PACKAGE

UNIT MAINTENANCE
SPACE HEATER, CONVECTIVE 60K BTU (SHC-60K)
NSN 4520-01-520-6477
LOAD BANK
INSPECT, TEST, REPLACE

INITIAL SETUP:**Tools**

Tool Kit, General Mechanic's (Item 1, WP 0067 00)

Personnel Required

One

Materials/Parts

None Required

Equipment Condition

Heater shut down, cool, and all advisory lights off (WP 0006 00).
Battery disconnected (WP 0043 00).
Upper housing assembly removed (WP 0052 00).

INSPECT**Inspect the Load Bank**

Inspect the load bank connectors (**Figure 1, Item 1**) and wires (**Figure 1, Item 2**) for physical damage, dirt, and corrosion.

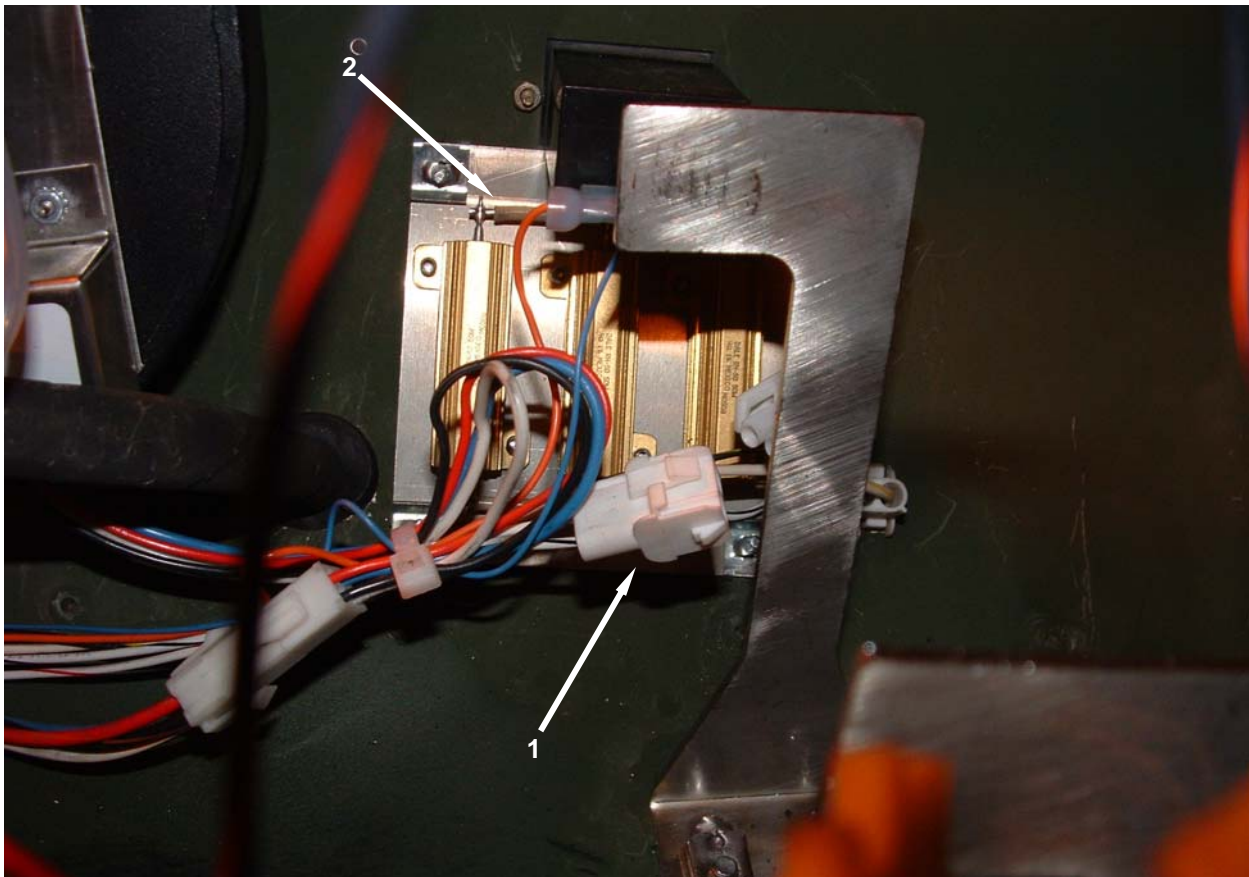

Figure 1. Inspect the Load Bank.

TEST**Test the Load Bank**

1. Locate and disconnect the load bank modular connector (**Figure 2, Item 1**).
2. Use an ohmmeter to measure resistance across the load bank terminals in the connector (**Figure 2, Item 1**). The correct resistance should be approximately 1.33 ohms (+/- 0.15 ohms). Replace an open or shorted load bank.
3. Reconnect the load bank modular connector (**Figure 2, Item 1**).

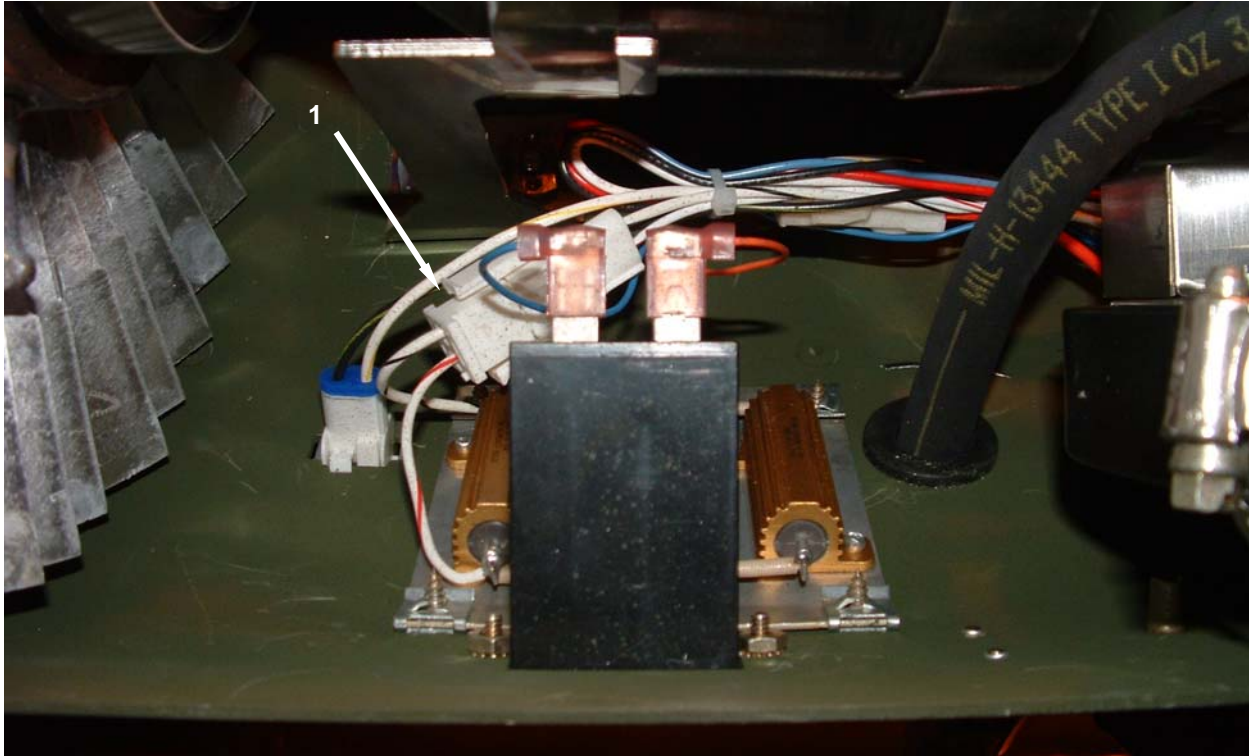
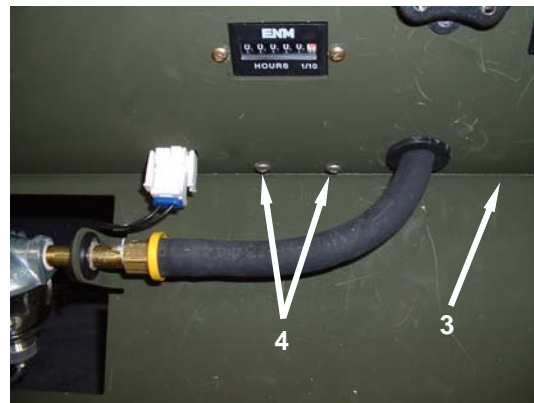
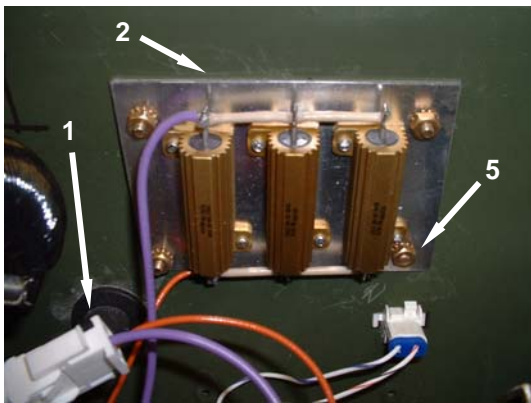

Figure 2. Test the Load Bank.

REPLACE**Replace Load Bank**

1. Disconnect connector (**Figure 3, Item 1**) leading to load bank assembly (**Figure 3, Item 2**).
2. Remove four screws, lockwashers, and nuts securing load bank assembly (**Figure 3, Item 2**) to lower housing assembly (**Figure 3, Item 3**). Two screws (**Figure 3, Item 4**) are located near fuel hose to right of sediment strainer assembly. Remaining two screws (**Figure 3, Item 5**) are located at underside of heater. Tip the heater on side to gain access to screws on underside of heater.
3. Remove load bank assembly (**Figure 3, Item 2**).
4. Install new load bank assembly by aligning holes at corner of assembly with holes in lower housing assembly.
5. Install four screws, lockwashers, and nuts (**Figure 3, Item 4 and Figure 3, Item 5**) removed previously.
6. Engage and secure connector (**Figure 3, Item 1**).

**Figure 3. Load Bank.****END OF WORK PACKAGE**

UNIT MAINTENANCE
SPACE HEATER, CONVECTIVE 60K BTU (SHC-60K)
NSN 4520-01-520-6477
FUEL SUPPLY QUICK DISCONNECT
INSPECT, REPLACE

INITIAL SETUP:**Tools**

Tool Kit, General Mechanic's (Item 1,
WP 0067 00)

Personnel Required

One

Materials/Parts

Compound, Sealer Pipe (Item 5, WP 0092 00)

Equipment Condition

Heater shut down, cool, and all advisory lights
off (WP 0006 00).

In-tent controller assembly disconnected from
heater (WP 0006 00).

Battery disconnected (WP 0043 00).

Fuel supply disconnected (WP 0006 00).

INSPECT**Inspect Fuel Supply Quick Disconnect**

WARNING

Be sure to disconnect battery connector before performing any maintenance actions. Failure to do so may cause sparking or short circuits which might cause a fire or damage heater components.

Inspect the fuel supply quick disconnect (**Figure 1, Item 1**) to ensure there are no cracks, dents, or other damage that would prevent the external fuel hose from attaching securely to the quick disconnect. There should be no fuel leaks when the fuel hose is attached.

REPLACE**Replace Fuel Supply Quick Disconnect**

1. To remove the fuel supply quick disconnect (**Figure 1, Item 1**), first place a petroleum absorbent mat under the quick disconnect.
2. Use a wrench and loosen the fuel supply quick disconnect by turning counter clockwise from the elbow fitting (**Figure 1, Item 2**) that is attached to the fuel solenoid valve (**Figure 1, Item 3**).
3. Remove the fuel supply quick disconnect.
4. Clean all residual sealant that may be present inside the elbow (**Figure 1, Item 2**).
5. Spread new sealant to the threads (**Figure 1, Item 4**) of the fuel quick disconnect (**Figure 1, Item 1**).
6. Install the fuel quick disconnect into the elbow fitting (**Figure 1, Item 2**). Tighten securely.

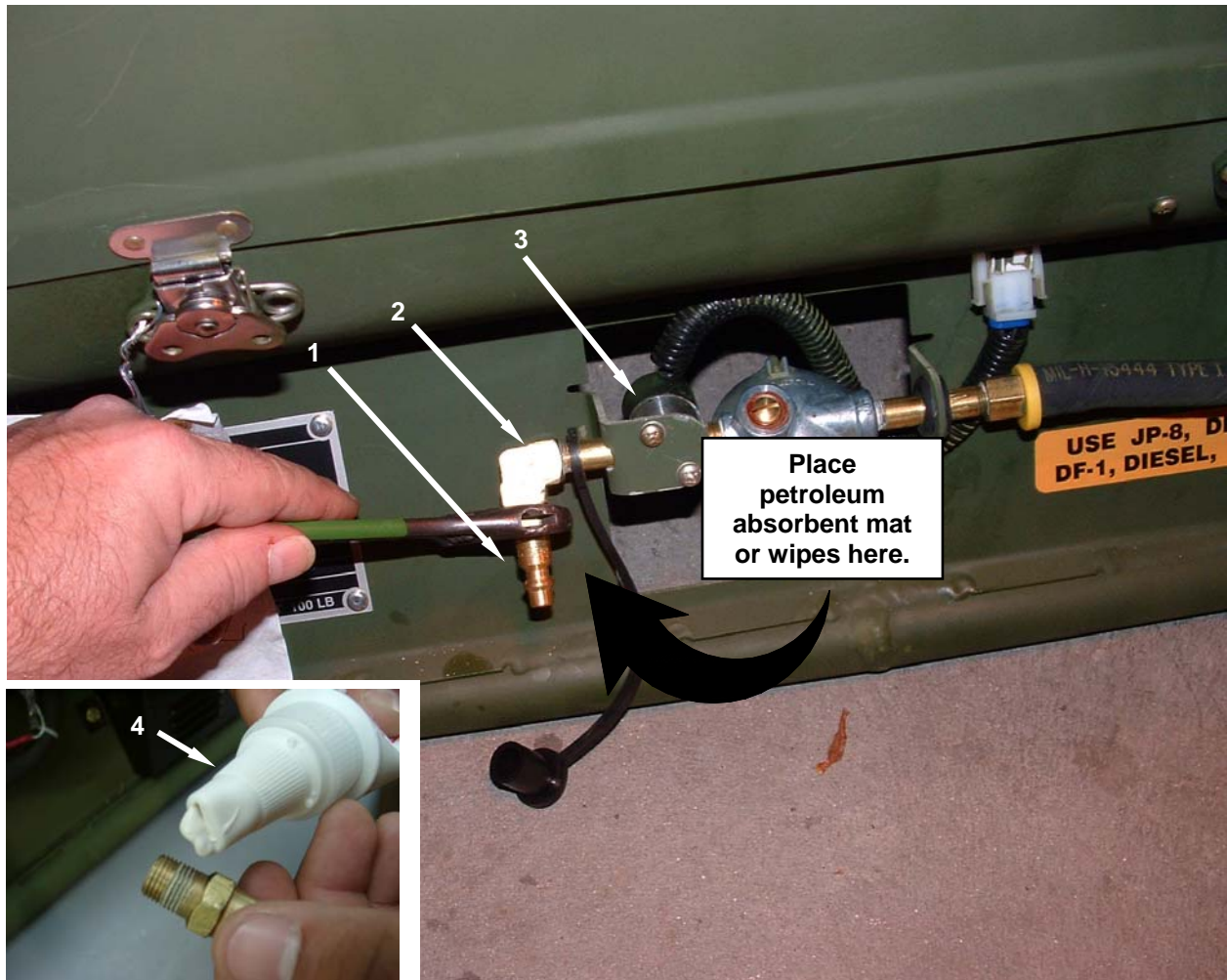

Figure 1. Fuel Supply Quick Disconnect.

END OF WORK PACKAGE

UNIT MAINTENANCE
SPACE HEATER, CONVECTIVE 60K BTU (SHC-60K)
NSN 4520-01-520-6477
FUEL SOLENOID VALVE AND SEDIMENT STRAINER ASSEMBLY
INSPECT, TEST, REPLACE

INITIAL SETUP:**Tools**

Tool Kit, General Mechanic's (Item 1, WP 0067 00)

Personnel Required

One

Materials/Parts

Baled Rag, General (Item 3, WP 0092 00)
 Compound, Sealer Pipe (Item 5, WP 0092 00)
 Gasket (Item 6, WP 0092 00)
 Mat, Petroleum Absorbent (Item 11, WP 0092 00)
 Screen (Item 12, WP 0092 00)

Equipment Condition

Heater shut down and cool, and all advisory lights off (WP 0006 00).
 In-tent controller assembly disconnected from heater (WP 0006 00).
 Battery disconnected (WP 0043 00).
 Fuel supply disconnected (WP 0006 00).

INSPECT**Inspect Fuel Solenoid and Sediment Strainer Assembly****WARNING**

Be sure to disconnect battery connector before performing any maintenance actions. Failure to do so may cause sparking or short circuits which might cause a fire or damage heater components.

1. Inspect the sediment strainer (**Figure 1, Item 1**) for any cracks, dents, or other damage that would restrict the flow of fuel from the fuel solenoid valve (**Figure 1, Item 2**) to the fuel hose (**Figure 1, Item 3**).
2. Ensure that there are no fuel leaks at the fittings (**Figure 1, Item 4**) or around the bowl area (**Figure 1, Item 5**) of the strainer.
3. Inspect the fuel solenoid valve (**Figure 1, Item 2**) for any cracks, dents, or other damage that would inhibit its proper operation or restrict the flow of fuel from the fuel solenoid valve (**Figure 1, Item 2**) to the sediment strainer (**Figure 1, Item 1**).
4. Ensure that the wires (**Figure 1, Item 6**) protected by the wire loom (**Figure 1, Item 7**) and leading to the fuel solenoid valve (**Figure 1, Item 1**) do not have any cuts or abrasions.
5. Inspect the connectors (**Figure 1, Item 8**) for any cracks or other damage that would prevent the connectors from having a secure electrical connection.

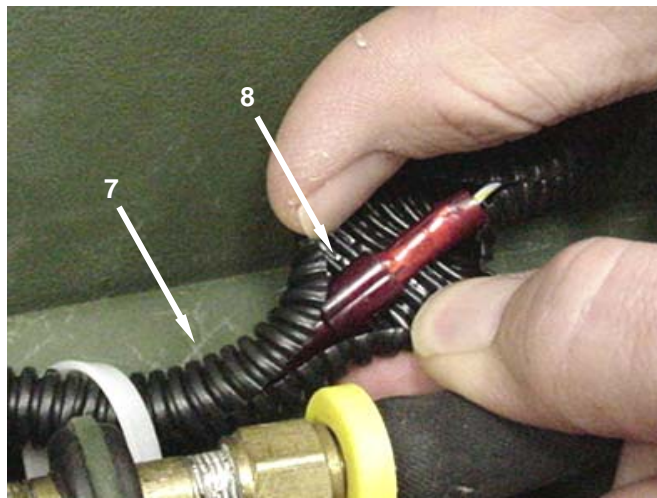
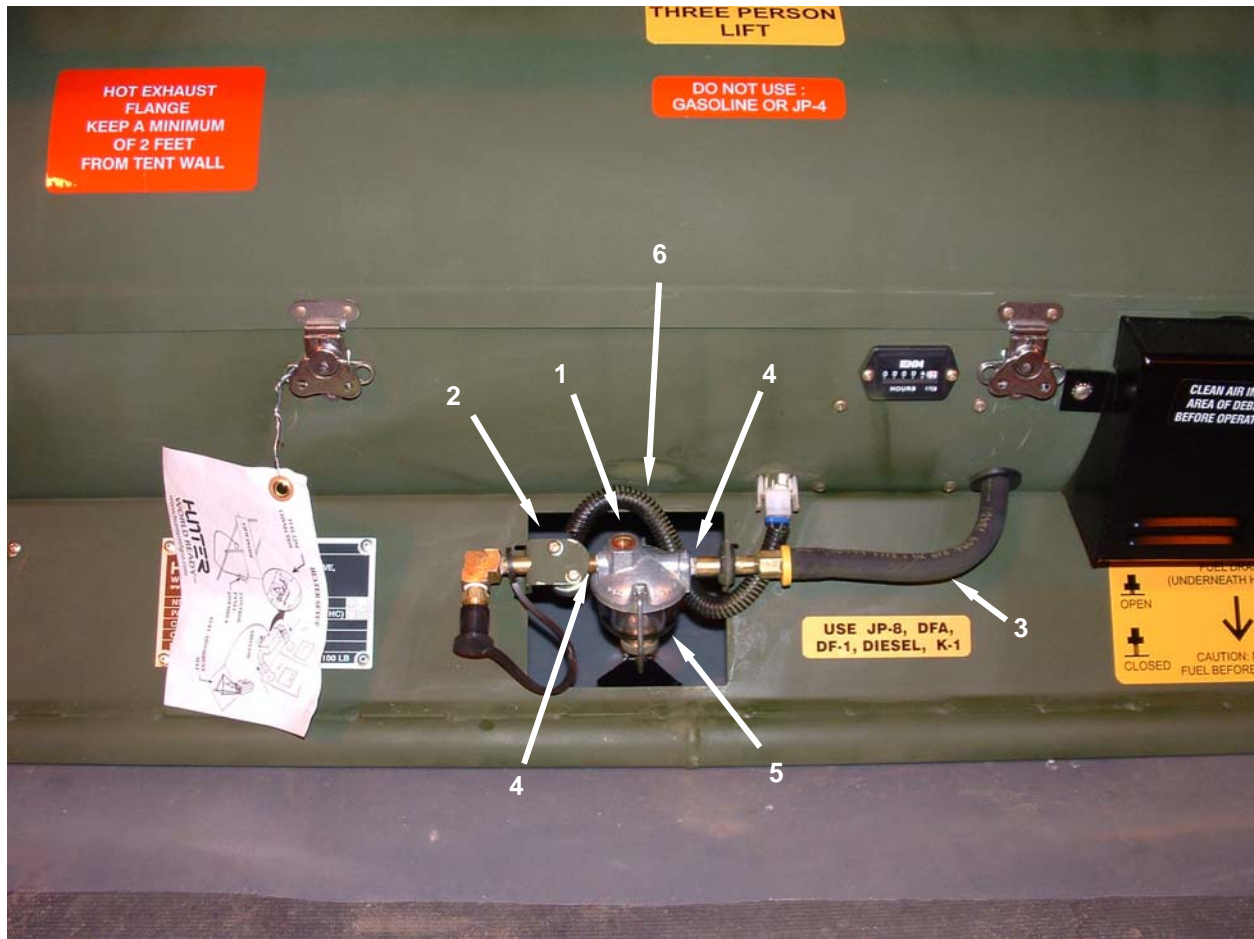

Figure 1. Inspect Fuel Solenoid and Sediment Strainer Assembly.

TEST**Test the Fuel Solenoid**

1. Disconnect the fuel solenoid electrical connector (**Figure 2, Item 1**).
2. Use an ohmmeter to test for resistance at the connector (**Figure 2, Item 1**). The correct value for the fuel solenoid is approximately 30 ohms resistance. Replace an open or shorted fuel solenoid.
3. Reconnect the fuel solenoid electrical connector (**Figure 2, Item 1**).

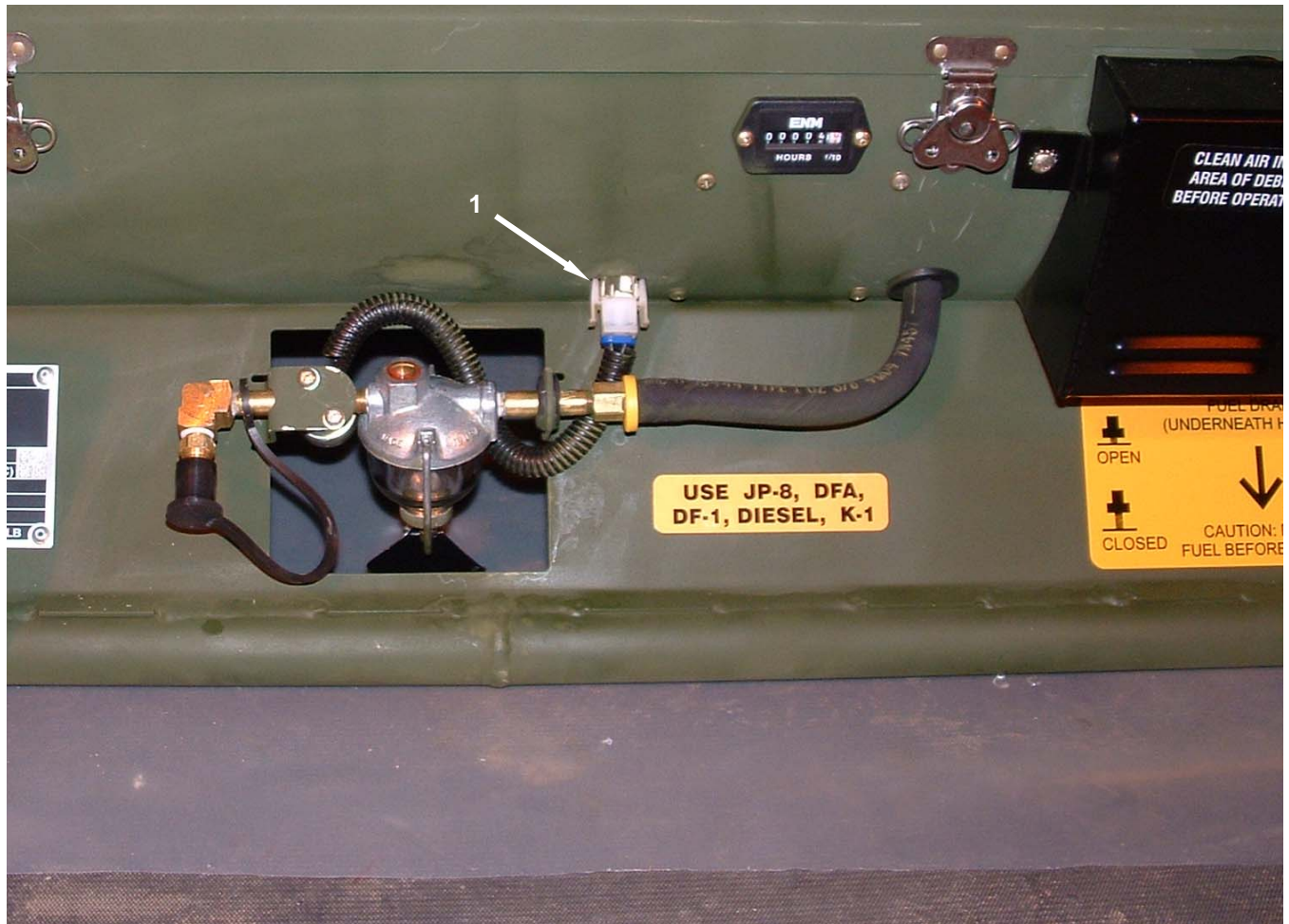

Figure 2. Test the Fuel Solenoid.

REPLACE

Replace Fuel Solenoid and Sediment Strainer Assembly



WARNING

Fuels are toxic and flammable. Wear eye/face protection, avoiding contact with skin and clothes, and don't breathe vapors. If contact with eyes or skin is made, immediately flush with clean water and get medical aid for eyes. If contact with clothing or skin is made, immediately remove contaminated clothing and clean skin with mild soap or cleanser and flush with clean water.

Always store fuel cans in a well-ventilated area as far away from open flames and other potential ignition sources as possible. Leaking or spilled fuels will create a fire danger-injuries/death and environmental damage. Fuel spills must be cleaned up in accordance with local requirements.

CAUTION

Thread sealant is used to seal the threads on the various fittings of the fuel solenoid and sediment strainer assembly. Once the sealant has set, it may require some force to break the sealant's bond. However, take care not to apply excessive force which could result in damage to the components.

1. Place a petroleum absorbent pad under the fuel solenoid valve and sediment strainer assembly (**Figure 3, Item 1**).
2. Before removing the fuel solenoid valve and sediment strainer assembly (**Figure 3, Item 1**), drain the sediment strainer of fuel by loosening the knurled nut (**Figure 3, Item 2**) at the base of the sediment strainer bowl (**Figure 3, Item 3**).
3. Rotate the bale (**Figure 3, Item 4**) upward while supporting the bowl (**Figure 3, Item 3**).
4. Rock the bowl (**Figure 3, Item 3**) slightly and remove it from the sediment strainer top assembly (**Figure 3, Item 5**).



WARNING

Fuels are toxic. Wear eye/face protection, impervious hand protection, avoid contact with skin and clothes, and don't breathe vapors. The use of protective gloves will significantly reduce the risks of exposure by prevent contact with skin. If contact with eyes or skin is made, immediately flush with clean water and get medical aid for eyes. If contact with clothing or skin is made, immediately remove contaminated clothing and clean skin with mild soap or cleanser and flush with clean water. Failure to observe these precautions could result in exposure to fuel, resulting in serious illness.

NOTE

Manage and dispose of fuel and fuel absorbent pads or wipes in accordance with appropriate state, local, and installation environmental regulations.

5. Empty the fuel from the bowl (**Figure 3, Item 3**) into an approved container and discard. Do not empty the fuel into a fresh fuel supply.
6. Cut the tie wrap (**Figure 3, Item 6**) securing the wire loom (**Figure 3, Item 7**) that protects the fuel solenoid valve electrical connectors and wires (**Figure 3, Item 8**) to the sediment strainer outlet fitting (**Figure 3, Item 9**). Disconnect the fuel solenoid valve connector (**Figure 3, Item 8**).
7. Remove the protective dust cap (**Figure 3, Item 10**) from the fuel quick disconnect (**Figure 3, Item 11**).
8. Remove the fuel quick disconnect (**Figure 3, Item 11**) as detailed in WP 0045 00 and set aside.
9. Remove the protective dust cap (**Figure 3, Item 10**) from the fuel quick disconnect (**Figure 3, Item 11**) and set aside.
10. Using a wrench, remove the fuel quick disconnect elbow fitting (**Figure 3, Item 12**) and set aside.
11. Wrap a rag around the end of the fuel hose (**Figure 3, Item 13**) and grasp the end of the fuel hose near the fuel hose fitting (**Figure 3, Item 14**) with a pair of pliers. Be sure that the rag is between the hose and the pliers so as to protect the hose from damage.
12. While holding the fuel hose (**Figure 3, Item 13**) securely, use a wrench to loosen the fuel hose fitting (**Figure 3, Item 14**). Remove the fuel hose fitting (**Figure 3, Item 14**) from the sediment strainer outlet fitting (**Figure 3, Item 9**). Have a petroleum absorbent mat or tray with absorbent material nearby to collect any fuel that may be in the fuel hose.
13. Remove the two screws (**Figure 3, Item 15**) that secure the fuel solenoid valve (**Figure 3, Item 16**) to the external fuel system bracket (**Figure 3, Item 17**).
14. While rotating the fuel solenoid valve and sediment strainer assembly (**Figure 3, Item 1**) back and forth slightly toward and away from the heater, slide the assembly to the right until the solenoid valve inlet fitting (**Figure 3, Item 18**) clears the external fuel system bracket (**Figure 3, Item 17**).

15. Drop the left end of the assembly with the solenoid valve inlet fitting (Figure 3, Item 18) down below the bracket (Figure 3, Item 17) and slide the assembly (Figure 3, Item 1) to the left while rotating slightly as described above. Continue until the assembly clears the sediment strainer bracket (Figure 3, Item 19) and rubber grommet (Figure 3, Item 20) to the right of the sediment strainer.

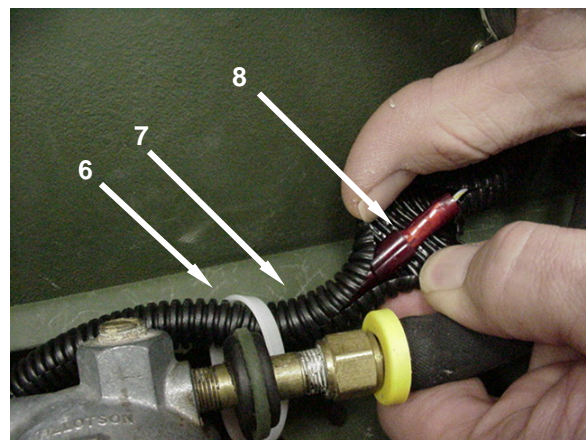
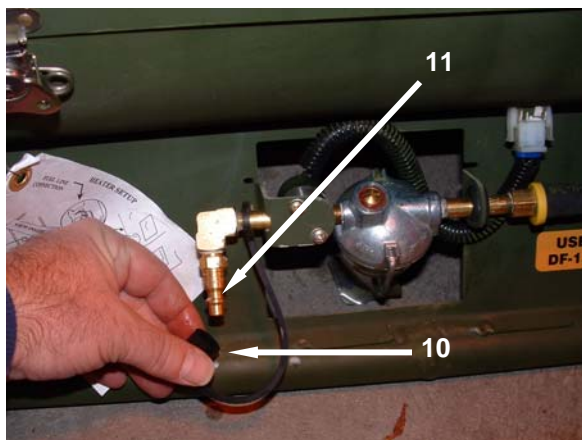
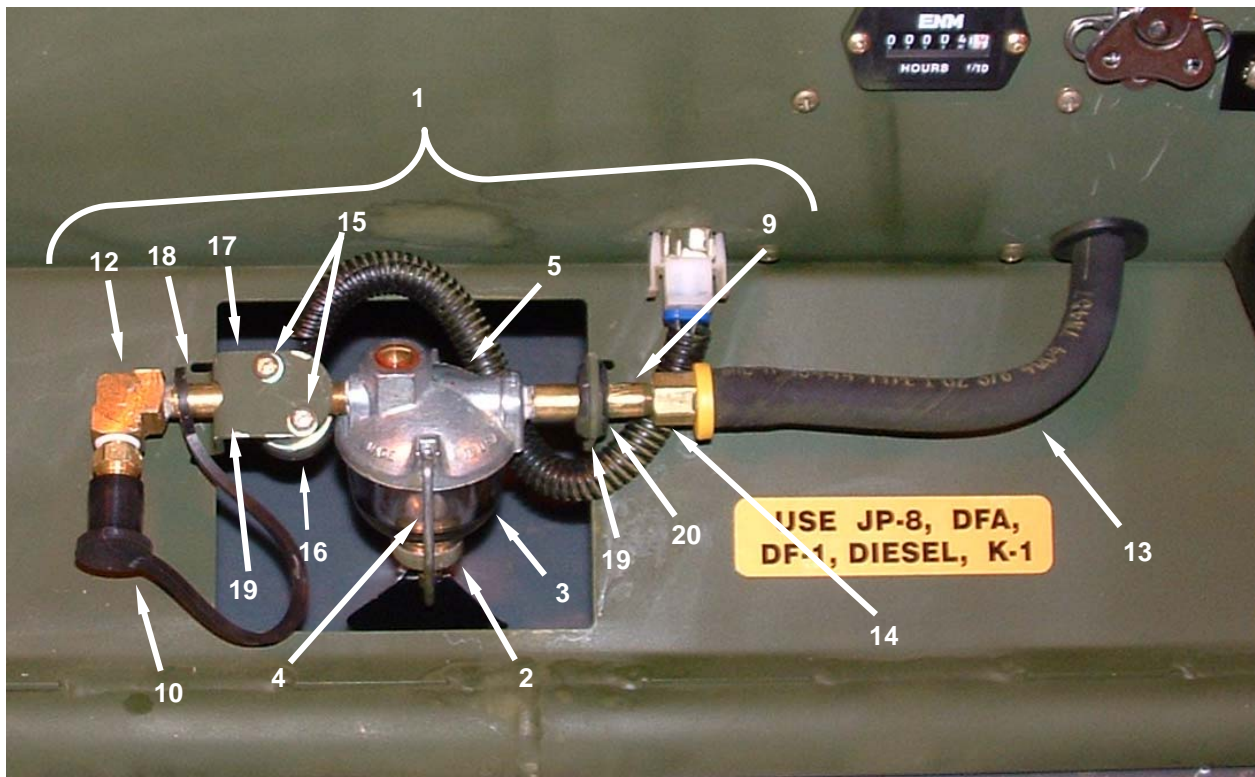

Figure 3. Replace Fuel Solenoid and Sediment Strainer Assembly.

16. To install a new solenoid valve and sediment strainer assembly (**Figure 4, Item 1**), insert the sediment strainer outlet fitting (**Figure 4, Item 2**) into the rubber grommet (**Figure 4, Item 3**) on the sediment strainer bracket (**Figure 4, Item 4**) closest the fuel hose (**Figure 4, Item 5**). Continue until the solenoid valve inlet fitting (**Figure 4, Item 18**) has cleared the external fuel system bracket (**Figure 4, Item 7**).
17. Swing the left end of the assembly with the solenoid valve inlet fitting (**Figure 4, Item 6**) under the external fuel system bracket (**Figure 4, Item 7**) and insert the fuel solenoid inlet fitting (**Figure 4, Item 6**) into the hole on the external fuel system bracket (**Figure 4, Item 7**).
18. Rotate the assembly (**Figure 4, Item 1**) while sliding the assembly to the left until the holes on the top of the fuel solenoid valve (**Figure 4, Item 8**) are aligned with the holes on the external fuel system bracket (**Figure 4, Item 7**).
19. Install the two screws (**Figure 4, Item 9**) through the external fuel system bracket (**Figure 4, Item 7**) and into the fuel solenoid valve (**Figure 4, Item 8**). Tighten securely.
20. Wrap a rag around the end of the fuel hose (**Figure 4, Item 5**) and grasp the end of the fuel hose near the fuel hose fitting (**Figure 4, Item 10**) with a pair of pliers. Be sure that the rag is between the hose and the pliers in order to protect the hose from damage.
21. While holding the fuel hose (**Figure 4, Item 5**) securely, use a wrench to engage the fuel hose fitting (**Figure 4, Item 10**) on the sediment strainer outlet fitting (**Figure 4, Item 2**). Make sure that the fittings (**Figure 4, Item 2 and 10**) engage correctly and do not cross-thread. Tighten the fuel hose fitting (**Figure 4, Item 10**) securely.
22. Install the protective dust cap (**Figure 4, Item 11**) onto the fuel quick disconnect (**Figure 4, Item 12**).

NOTE

Orient fuel quick disconnect downward. Bowl orientation is down.

23. Clean any residual thread sealant from the threads of the fuel quick disconnect elbow fitting (**Figure 4, Item 13**) that was removed and set aside earlier. Apply new thread sealant to the threads of the fuel solenoid inlet fitting (**Figure 4, Item 6**). Tighten the fuel quick disconnect elbow fitting securely taking care to align the opening (**Figure 4, Item 14**) on the elbow fitting so that it faces outward.
24. Clean any residual thread sealant from threads of the fuel quick disconnect (**Figure 4, Item 12**).
25. Apply new thread sealant to the threads of the fuel quick disconnect (**Figure 4, Item 12**).
26. Install the fuel quick disconnect (**Figure 4, Item 12**) into the fuel quick disconnect elbow fitting (**Figure 4, Item 13**) and tighten securely.
27. Reconnect the fuel solenoid valve electrical connectors (**Figure 4, Item 15**). Install the wire loom (**Figure 4, Item 16**) over the fuel solenoid wires and connectors (**Figure 4, Item 15**). Install a new tie wrap (**Figure 4, Item 17**) over the wire loom and bracket (**Figure 4, Item 4**) to secure the wire loom to the sediment strainer outlet fitting (**Figure 4, Item 2**).

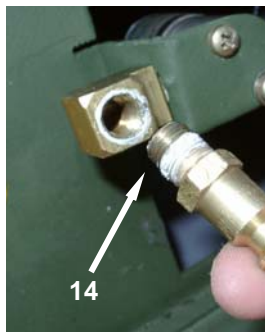
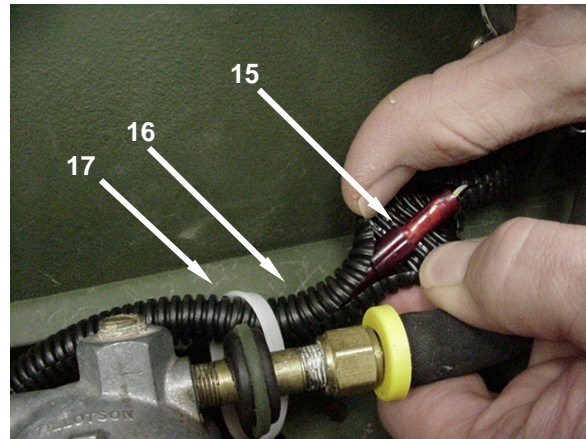
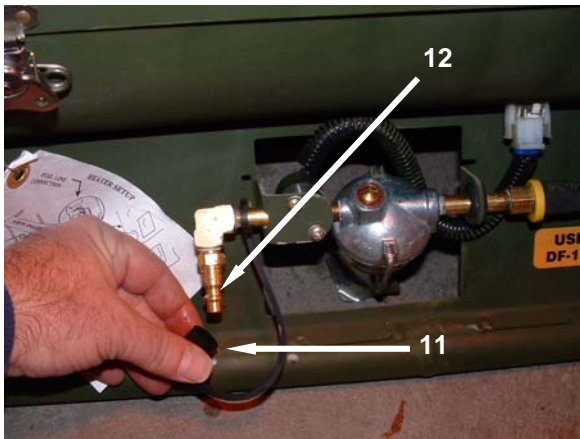
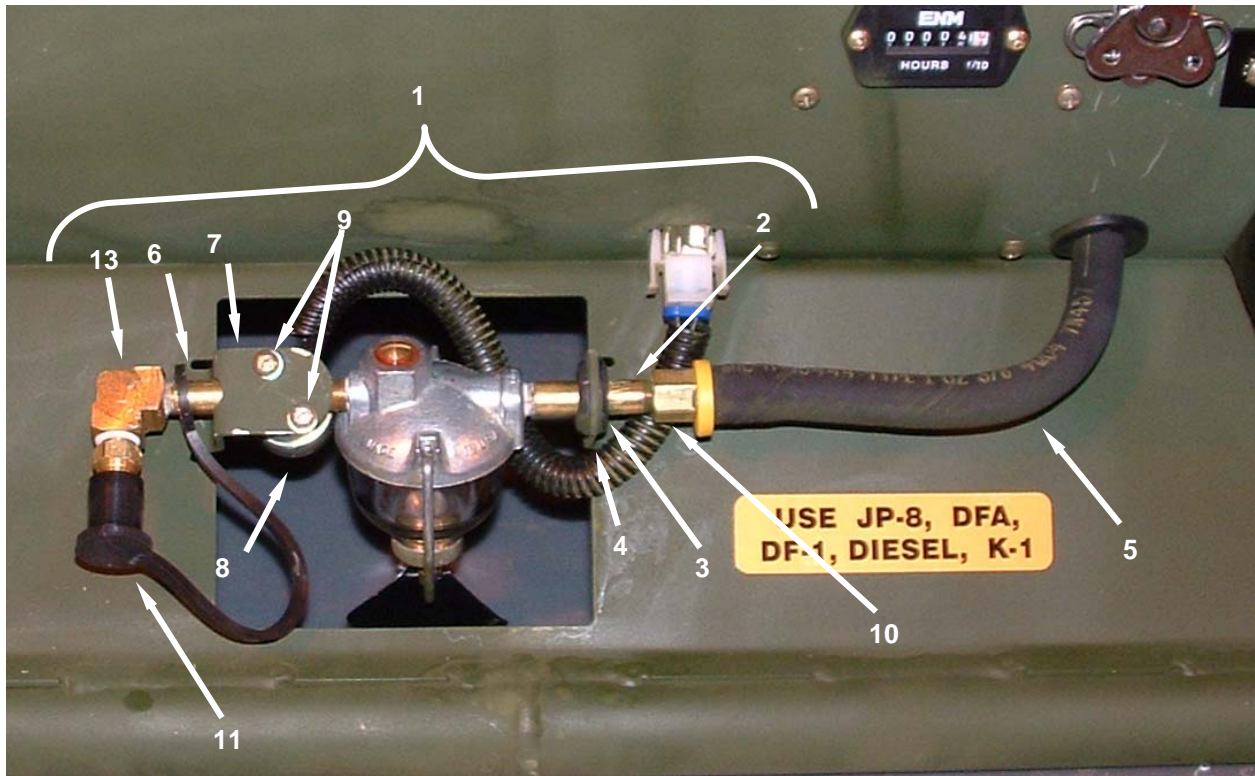

Figure 4. Replace Fuel Solenoid and Sediment Strainer Assembly.

END OF WORK PACKAGE

**UNIT MAINTENANCE
SPACE HEATER, CONVECTIVE 60K BTU (SHC-60K)
NSN 4520-01-520-6477
FUEL HOSE
INSPECT, REPLACE**

INITIAL SETUP:**Tools**

Tool Kit, General Mechanic's (Item 1, WP 0067 00)

Personnel Required

One

Materials/Parts

Baled Rag, General (Item 3, WP 0092 00)
Mat, Petroleum Absorbent
(Item 11, WP 0092 00)
Tie, Wire (Item 17, WP 0092 00)

Equipment Condition

Heater shut down and cool, and all advisory lights off (WP 0006 00).
In-tent controller assembly disconnected from heater (WP 0006 00).
Fuel supply disconnected (WP 0006 00).
Sediment strainer bowl empty of fuel (WP 0046 00).
Battery disconnected (WP 0043 00).
Upper housing assembly removed (WP 0052 00).

INSPECT**Inspect a Fuel Hose****WARNING**

Be sure to disconnect battery connector before performing any maintenance actions. Failure to do so may cause sparking or short circuits which might cause a fire or damage heater components.

1. Inspect the fuel hose (**Figure 1, Item 1**) and fittings (**Figure 1, Item 2**) for any cuts, abrasions, dents, or other damage that may cause the fuel hose to leak.
2. Inspect the rubber grommet (**Figure 1, Item 3**) where the fuel hose passes through the side of the lower housing assembly for any damage that would prevent it from protecting the fuel hose from the sheet metal edges of the lower housing assembly.

REPLACE

Replace a Fuel Hose

1. Place a petroleum absorbent mat under the sediment strainer bowl (**Figure 1, Item 1**). Remove and empty the sediment strainer bowl, and then reinstall the sediment strainer bowl.
2. Holding the fuel hose (**Figure 1, Item 2**) securely, use a wrench to loosen the fuel hose fitting (**Figure 1, Item 3**). Remove the fuel hose fitting from the sediment strainer outlet fitting (**Figure 1, Item 4**). Have a petroleum absorbent mat or tray with absorbent material nearby to collect any fuel that may be in the fuel hose.
3. Place a petroleum absorbent mat under the hose (**Figure 1, Item 2**) and fuel hose fitting (**Figure 1, Item 3**), and wrap a rag around the end of the fuel hose which is connected to the float assembly inlet fitting (**Figure 1, Item 5**) and grasp the end of the fuel hose near the fuel hose fitting (**Figure 1, Item 6**) with a pair of pliers. Be sure that the rag is between the hose and the pliers to protect the hose from damage.
4. Holding the fuel hose (**Figure 1, Item 2**) securely, use a wrench to loosen the fuel hose fitting (**Figure 1, Item 6**). Remove the fuel hose fitting from the float assembly inlet fitting (**Figure 1, Item 5**). Place a small section of petroleum absorbent mat at the base of the lower heater housing to collect any residual fuel that may be in the fuel hose.
5. Place a petroleum absorbent mat under the hose (**Figure 1, Item 2**) and fuel hose fitting (**Figure 1, Item 3**), and wrap a rag around the end of the fuel hose connected to the sediment strainer outlet fitting (**Figure 1, Item 4**) and grasp the end of the fuel hose near the fuel hose fitting with a pair of pliers. Be sure that the rag is between the hose and the pliers to protect the hose from damage.
6. Pull the fuel hose and rubber grommet (**Figure 1, Item 7**) out through the opening in lower housing assembly. Remove the grommet from the hose and re-install it back in the lower housing assembly opening.
7. Install a new fuel hose (**Figure 1, Item 2**) by inserting the end of the fuel hose with the fitting that installs to the sediment strainer assembly through the rubber grommet (**Figure 1, Item 7**) from the inside of the heater, guiding it out of the lower heater housing. Move the fuel hose fitting (**Figure 1, Item 6**) into position near the float assembly inlet fitting (**Figure 1, Item 5**).
8. Wrap a rag around the end of the fuel hose (**Figure 1, Item 2**) which is to be connected to the float assembly inlet fitting (**Figure 1, Item 5**) and grasp the end of the fuel hose near the fuel hose fitting (**Figure 1, Item 6**) with a pair of pliers. Be sure that the rag is between the hose and the pliers to protect the hose from damage.
9. Holding the fuel hose (**Figure 1, Item 2**) securely, use a wrench to tighten the fuel hose fitting (**Figure 1, Item 6**) securely.
10. Wrap a rag around the end of the fuel hose (**Figure 1, Item 2**) which is to be connected to the sediment strainer outlet fitting (**Figure 1, Item 4**) and grasp the end of the fuel hose near the fuel hose fitting (**Figure 1, Item 3**) with a pair of pliers. Be sure that the rag is between the hose and the pliers to protect the hose from damage.
11. Holding the fuel hose (**Figure 1, Item 2**) securely, use a wrench to tighten the fuel hose fitting (**Figure 1, Item 3**) onto the sediment strainer outlet fitting (**Figure 1, Item 4**).

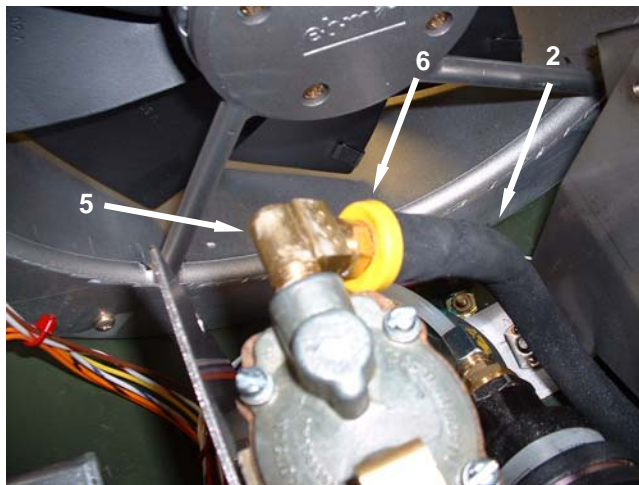
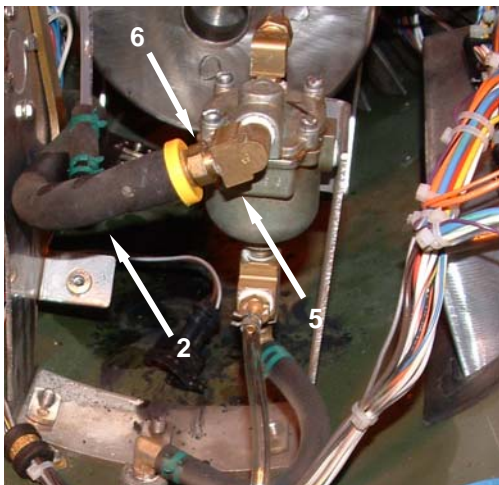
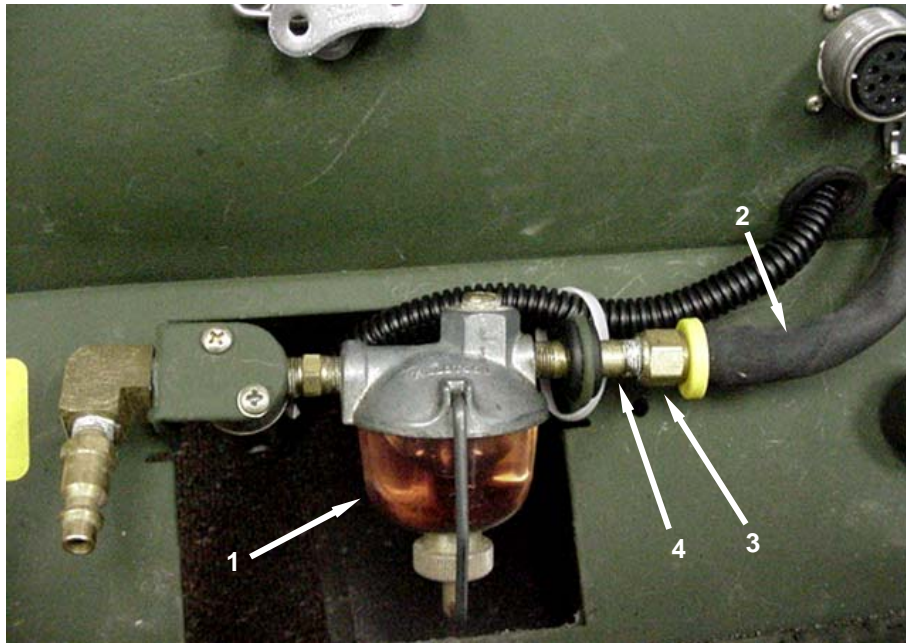

Figure 1. Fuel Hose.

END OF WORK PACKAGE

UNIT MAINTENANCE
SPACE HEATER, CONVECTIVE 60K BTU (SHC-60K)
NSN 4520-01-520-6477
ELECTRONICS BOX ASSEMBLY, COMPLETE WITH WIRE HARNESS
INSPECT, REPAIR, REPLACE

INITIAL SETUP:**Tools**

Tool Kit, General Mechanic's (Item 1, WP 0067 00)

Personnel Required

One

Materials/Parts

Tape, Electrical (Item 16, WP 0092 00)

Tie, Wire (Item 17, WP 0092 00)

Wire Markers (Item 19, WP 0092 00)

Equipment Condition

Heater shut down, cool, and all advisory lights off (WP 0006 00).

In-tent controller assembly disconnected from heater (WP 0006 00).

Fuel supply disconnected (WP 0006 00).

Battery disconnected (WP 0043 00).

Upper housing assembly removed (WP 0052 00).

INSPECT**Inspect Wire Harness**

WARNING

Be sure to disconnect battery connector before performing any maintenance actions. Failure to do so may cause sparking or short circuits which might cause a fire or damage heater components.

1. Inspect the connectors (**Figure 1, Item 1**) on the wire harness to ensure that all connectors are securely mated and locked together.
2. Inspect the wires (**Figure 1, Item 2**) for any cuts or abrasions to the insulation that would expose bare wire. Repair any breaks or abrasions as detailed below.
3. Inspect the tie wraps (**Figure 1, Item 3**) and ensure that none are broken or cut. Replace any tie wraps that are damaged.

REPAIR

Repair Wire Harness

1. Repair any cuts or abrasions on the wires (**Figure 1, Item 2**) with electrical tape, wrapping each repaired area with at least two layers of tape. Refer to WP 0040 00 for additional wire repair instructions as needed.
2. Repair tie wraps (**Figure 1, Item 3**) by removing any broken pieces and installing a new tie wrap.
3. Breaks in wiring may be repaired by soldering or by the installation of butt connectors or wire nuts as available. All such repairs must be thoroughly reinsulated with at least two layers of electrical tape.

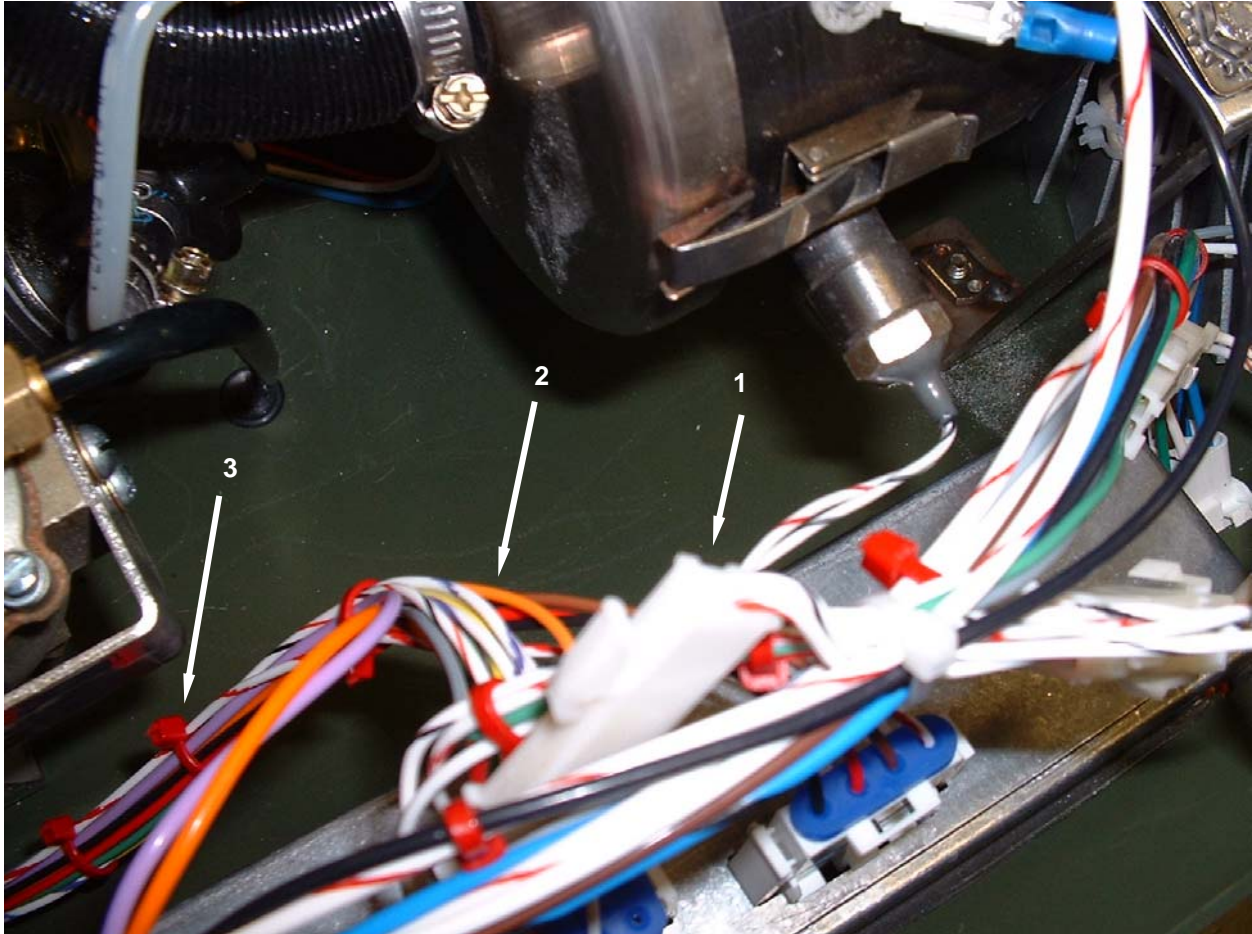

Figure 1. Wire Harness.

REPLACE**Replace the Electronic Box Assembly, Complete with Wire Harness****NOTE**

The SHC-60K wiring harness is constructed in a manner that minimizes the chance of mismatching connectors. It is still advisable that the maintainer mark all wire connections before attempting replacement of the harness, and observe a “wire for wire” replacement when installing the replacement harness.

NOTE

Ensure that you have a clean, preferably elevated workspace, with plenty of room to position yourself and the heater as needed.

1. Remove air inlet cover (**Figure 2, Item 1**).
2. Ensure all spare parts that may be stored on the heated air blower assembly (**Figure 2, Item 2**) are in place.



Figure 2. Replace the Electronic Box Assembly, Complete with Wire Harness – Remove the Heated Air Blower.

3. Remove three screws (**Figure 3, Item 1**) that secure the heated air blower assembly (**Figure 3, Item 2**) to lower assembly (**Figure 3, Item 3**).
4. Tag wires (**Figure 3, Item 4**) on both sides of terminal connector (**Figure 3, Item 5**) to ensure proper replacement.
5. Loosen terminal screws inside the air blower assembly connectors (**Figure 3, Item 5**); disconnect wires (**Figure 3, Item 4**) from heated air blower assembly. Pull wires from the heated air blower assembly (**Figure 3, Item 2**).
6. Disconnect the inlet air temperature sensor (**Figure 3, Item 6**).
7. Remove the heated air blower assembly (**Figure 3, Item 2**).

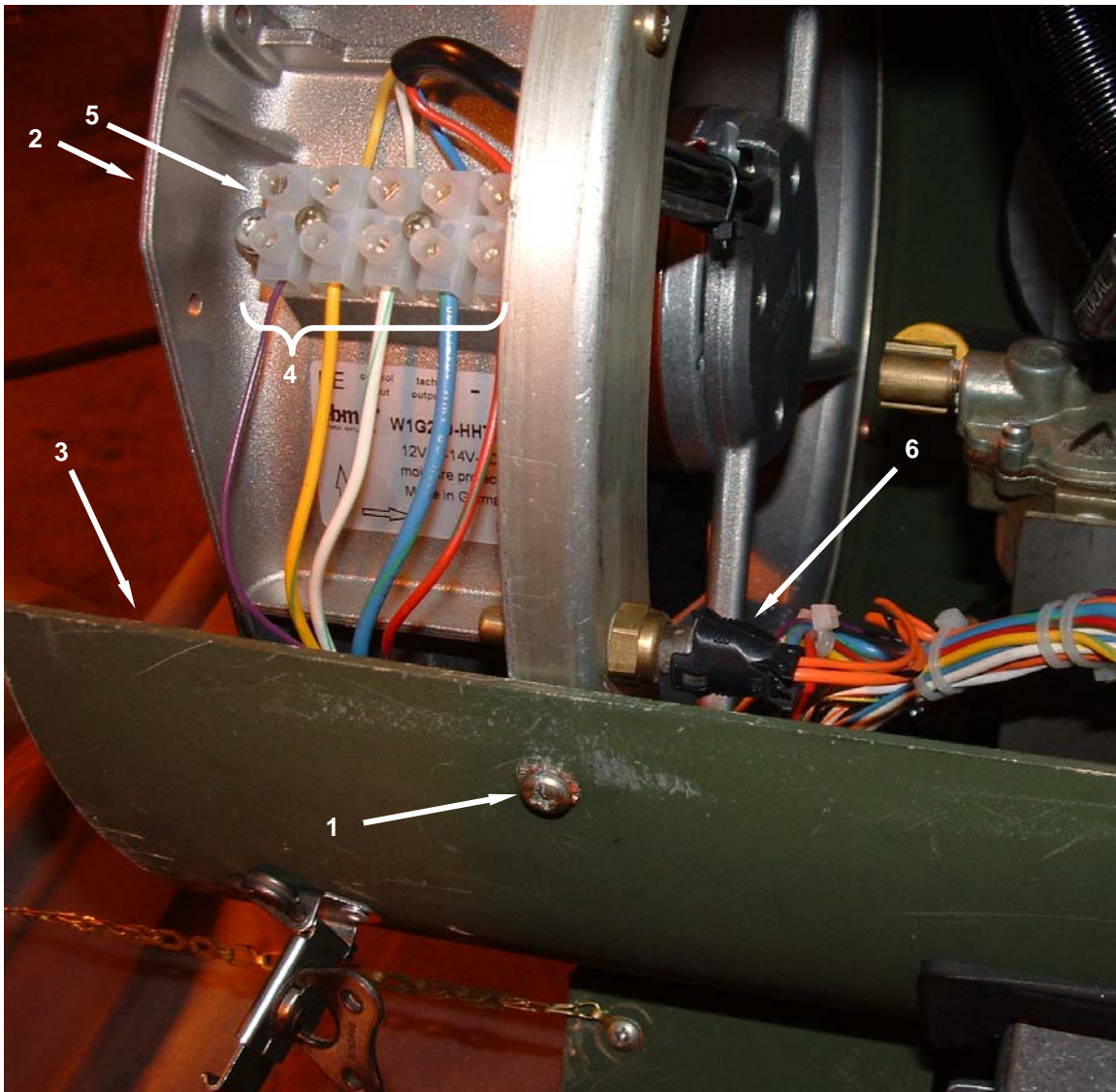

Figure 3. Replace the Electronic Box Assembly, Complete with Wire Harness – Remove the Heated Air Blower (Continued).

8. Unscrew wire clamp (**Figure 4, Item 1**) on bottom of heater to release harness (**Figure 4, Item 2**), and retain for installation of replacement electronics box assembly, complete with wire harness.
9. Remove the battery connector (**Figure 4, Item 3**) by pushing through the hole in the heater body.

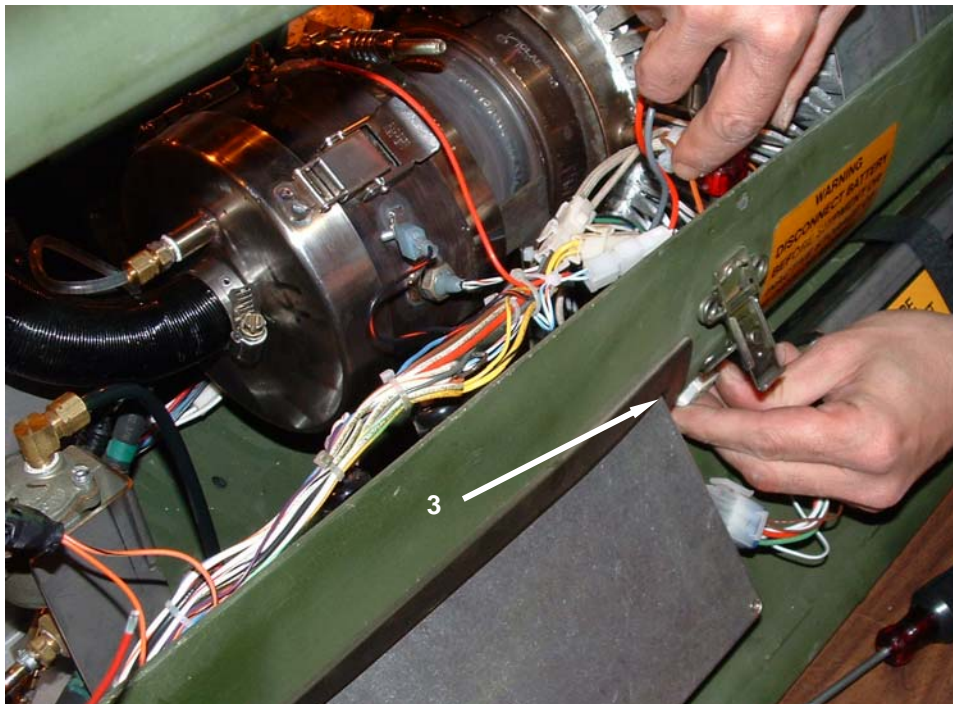
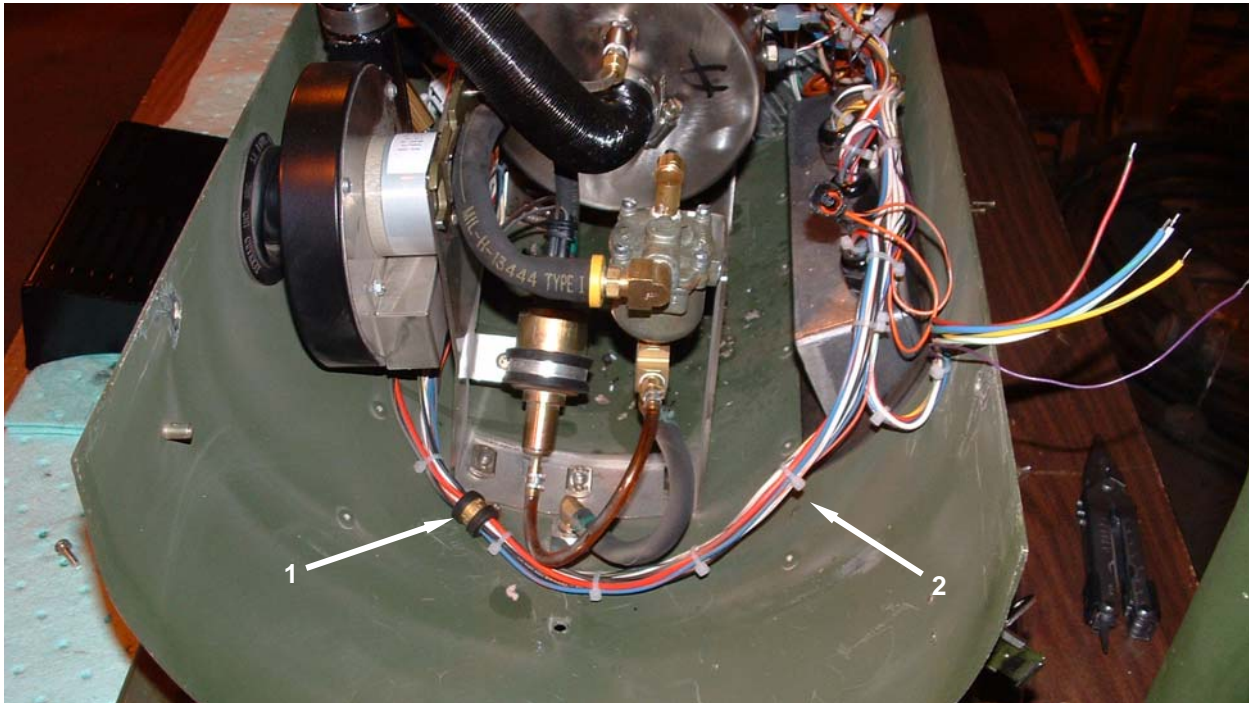

Figure 4. Replace the Electronic Box Assembly, Complete with Wire Harness – Disconnect Battery Connection.

10. Push the solenoid connector (**Figure 5, Item 1**) through the hole in the heater body.
11. Cut the wire tie retaining the harness (**Figure 5, Item 2**) to the fuel pump (**Figure 5, Item 3**).

CAUTION

Do not pull the wire clip securing the electrical quick disconnect to the fuel pump.

12. Disconnect the fuel pump electrical connector (**Figure 5, Item 4**) by pressing the wire clip on the connector.



Figure 5. Replace the Electronic Box Assembly, Complete with Wire Harness – Disconnect Fuel Pump.

13. Tag and disconnect remaining harness connections (**Figure 6, Item 1**).
14. Remove the screws retaining the electronics box assembly (**Figure 6, Item 2**), and pull the electronics box assembly, complete with harness, from the heater.
15. Feed the replacement harness into the heater, install the electronics box assembly (**Figure 6, Item 2**) and retain with screws. Ensure the wiring is routed neatly and free of any possible pinch points or stretching.

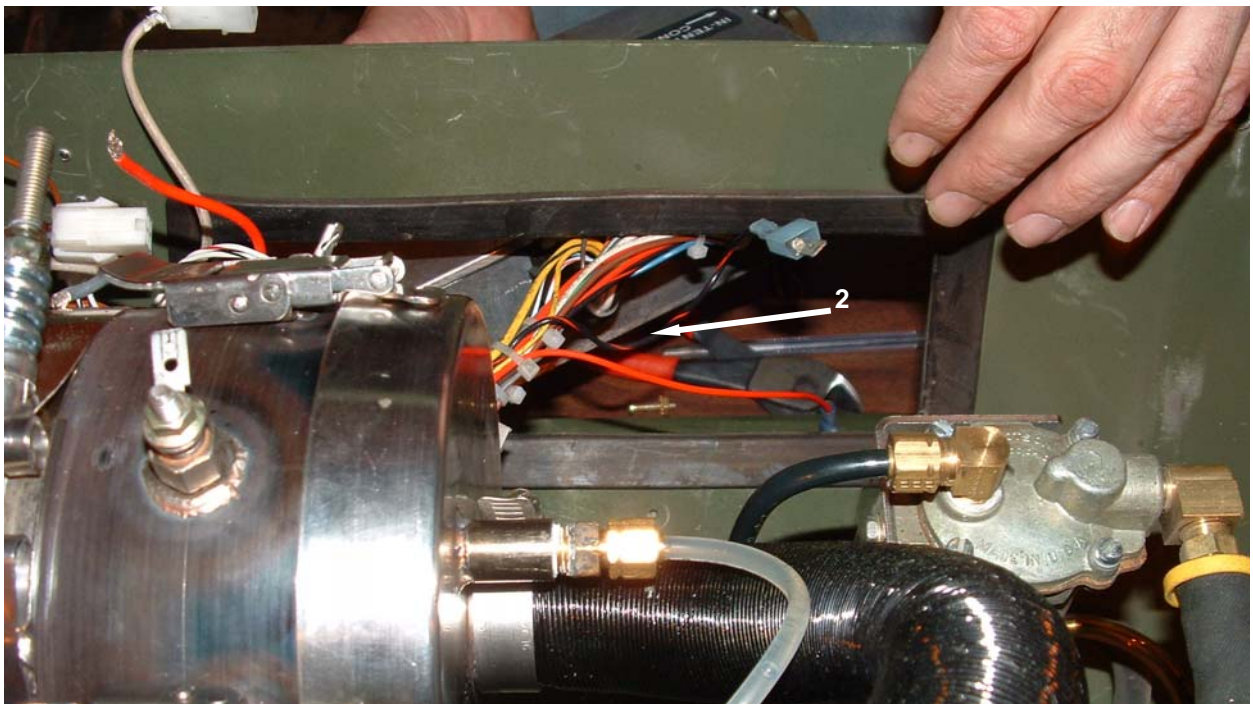
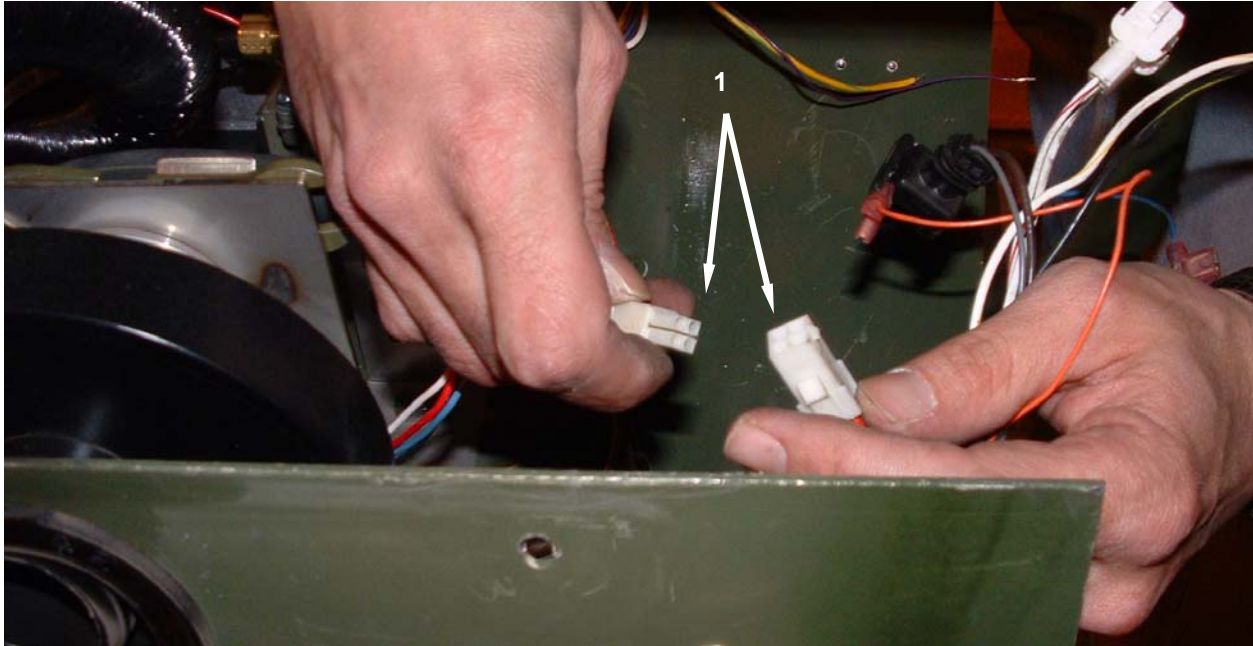

Figure 6. Replace the Electronic Box Assembly, Complete with Wire Harness – Disconnect Remaining Connections and Remove Assembly.

CAUTION

Do not pull the wire clip securing the electrical quick disconnect to the fuel pump.

16. Connect the fuel pump electrical connector (**Figure 7, Item 1**) by pressing the wire clip on the connector.
17. Push the solenoid connector (**Figure 7, Item 2**) through the hole in the heater body.

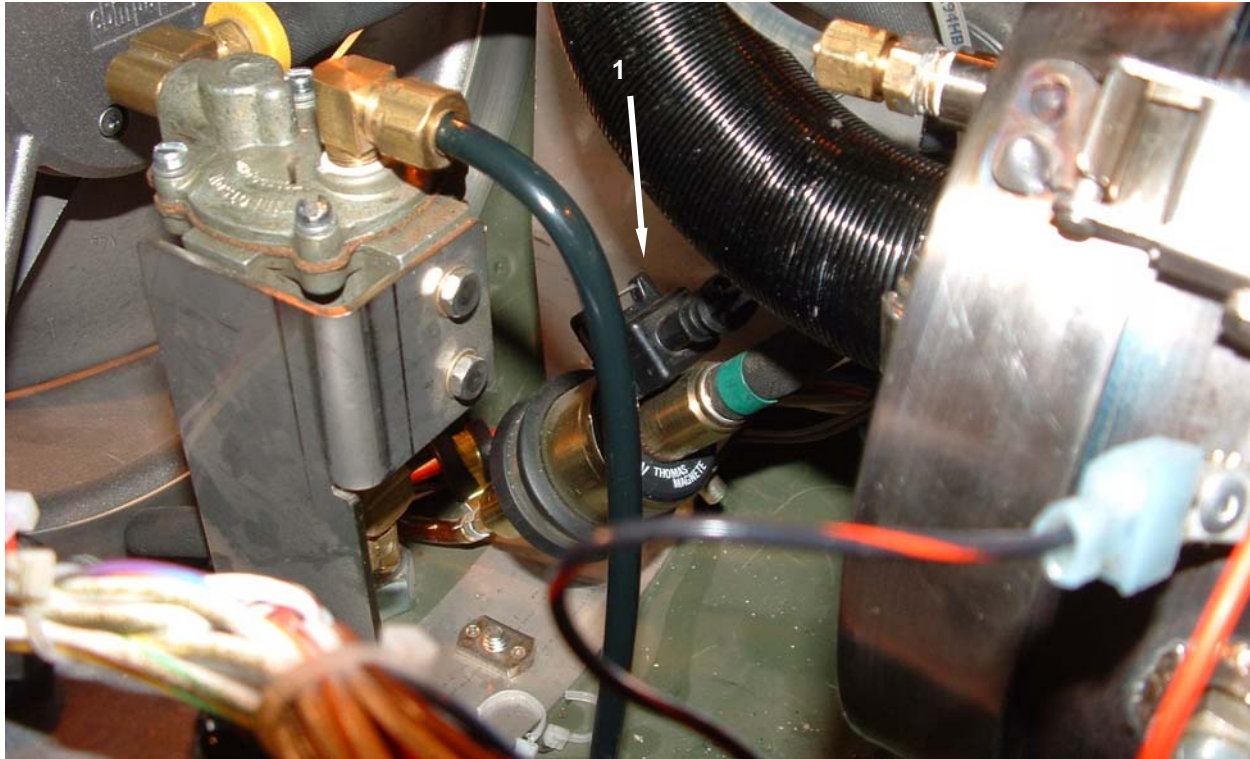

Figure 7. Replace the Electronic Box Assembly, Complete with Wire Harness – Connect Fuel Pump.

18. Install the battery connector (**Figure 8, Item 1**) by pushing through the hole in the heater body.
19. Reattach the wire clamp (**Figure 8, Item 2**) on the bottom of the heater, and install additional wire ties as necessary to ensure the wire harness (**Figure 8, Item 3**) is routed correctly.

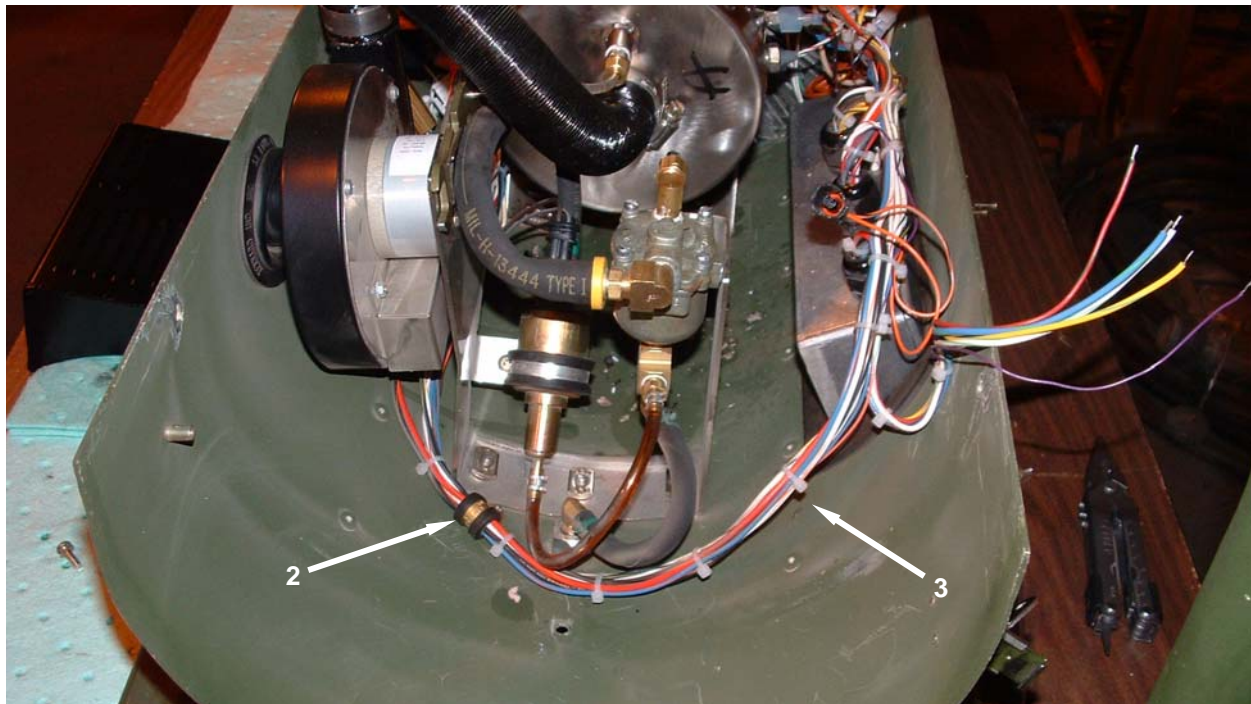
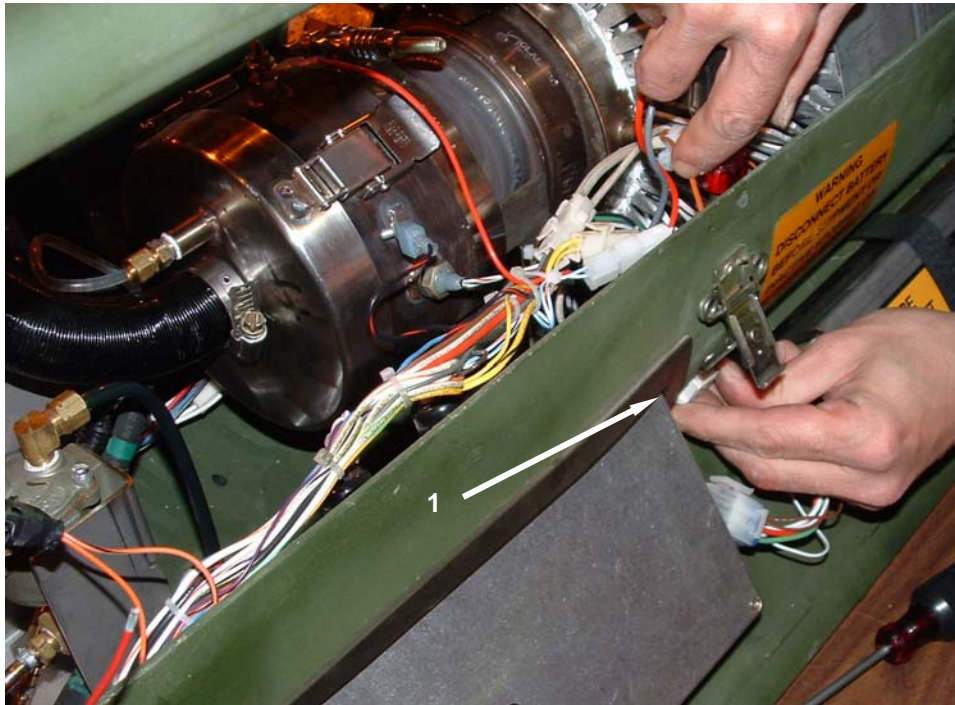

Figure 8. Replace the Electronic Box Assembly, Complete with Wire Harness – Connect Battery Connection.

CAUTION

The harness connectors have been fitted in a way that ensures that each separate connection is unique, preventing accidental miswiring. Do not force a connection – if it doesn't fit easily, it's incorrect.

20. Reconnect all remaining wiring connections (**Figure 9, Item 1**) as tagged.

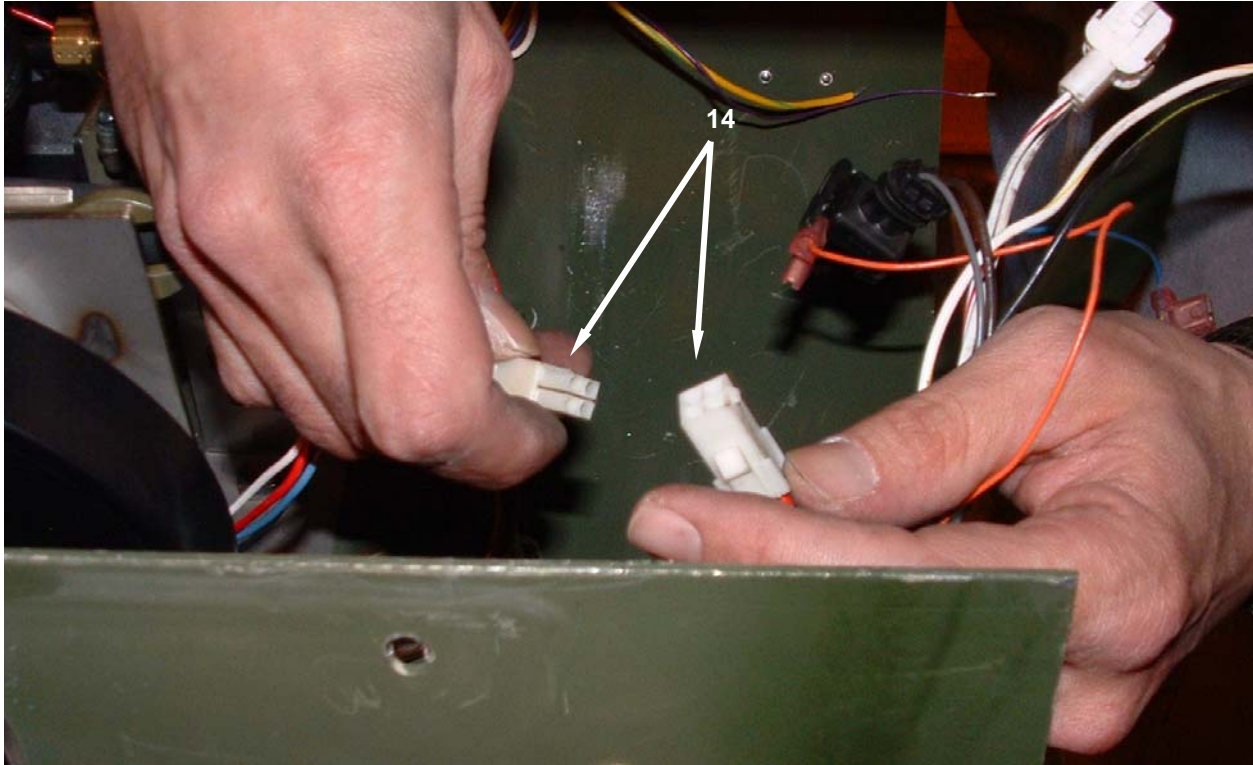

Figure 9. Replace the Electronic Box Assembly, Complete with Wire Harness – Reconnect Remaining Wiring.

21. Position the heater air blower assembly (**Figure 10, Item 1**), over the three holes on the lower assembly (**Figure 10, Item 2**).
22. Pull wires (**Figure 10, Item 3**) through the heated air blower assembly (**Figure 10, Item 4**).
23. Install the heated air blower assembly (**Figure 10, Item 4**) to lower housing assembly (**Figure 10, Item 2**), and retain with three screws (**Figure 10, Item 5**).

CAUTION

Ensure air blower assembly wiring is protected by the rubber grommet installed in the body of the air blower assembly. Improper installation may cause wires to chafe and short circuit, rendering the heater inoperable.

24. Place wires (**Figure 10, Item 3**) inside the air blower assembly connectors (**Figure 10, Item 6**); tighten terminal screws to secure.
25. Reconnect inlet air temperature sensor (**Figure 10, Item 7**).

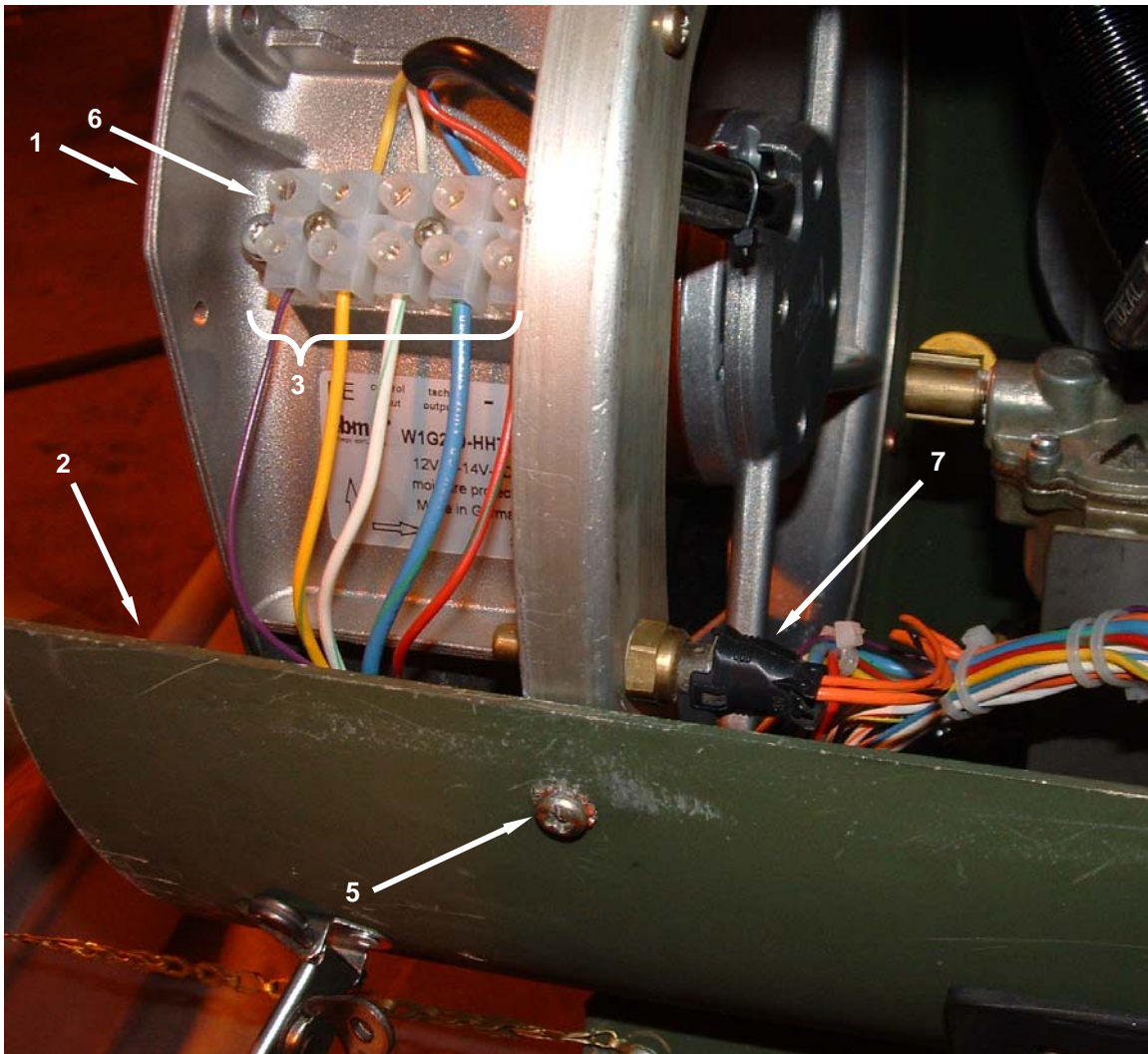

Figure 10. Replace the Electronic Box Assembly, Complete with Wire Harness – Install the Heated Air Blower.

26. Install the air inlet cover (**Figure 11, Item 1**).
27. Refit any spare parts that may have been removed, install upper housing, reinstall duct adapters, and verify normal operation IAW WP 0006 00.



Figure 11. Replace the Electronic Box Assembly, Complete with Wire Harness – Complete Installation.

END OF WORK PACKAGE

**UNIT MAINTENANCE
SPACE HEATER, CONVECTIVE 60K BTU (SHC-60K)
NSN 4520-01-520-6477
DUST COVER ASSEMBLY
INSPECT, REPLACE**

INITIAL SETUP:**Tools**

Tool Kit, General Mechanic's (Item 1, WP 0067 00)

Personnel Required

One

Materials/PartsAlcohol, Isopropyl (Item 2, WP 0092 00)
Baled Rag, General (Item 3, WP 0092 00)**Equipment Condition**

Heater shut down, cool, and all advisory lights off (WP 0006 00).

INSPECT**Inspect the Dust Cover****WARNING**

Isopropyl alcohol is flammable, toxic, and hazardous to eyes, skin, and respiratory tract. Impervious hand and eye protection is required. Avoid unprotected, repeated, or prolonged contact. If contact with eyes is made, immediately flush with clean water seek medical attention. Use only in well ventilated areas. Keep away from open flames or other sources of ignition.

1. Inspect the dust cover (**Figure 1, Item 1**) for any dents, cracks, cuts, or other damage that would prevent the dust cover from covering the duct adapter and properly protecting the heater from dust, sand, or other foreign matter.
2. Inspect the chain (**Figure 1, Item 2**) for any cuts or breaks that would prevent it from securing the dust cover to the lower housing of the heater.
3. Wipe dust cover (**Figure 1, Item 1**) thoroughly with a clean, dry rag. For oily or stubborn dirt, moisten rag with alcohol.

REPLACE**Replace the Dust Cover**

1. Pull dust cover (**Figure 1, Item 1**) off duct adapter (**Figure 1, Item 3**).
2. Remove screw (**Figure 1, Item 4**), lockwasher (**Figure 1, Item 5**), flat washer (**Figure 1, Item 6**), nut (**Figure 1, Item 7**), chain (**Figure 1, Item 2**), and dust cover (**Figure 1, Item 1**). Discard damaged dust cover.
3. Position chain over hole in lower housing and install screw (**Figure 1, Item 4**), lockwasher (**Figure 1, Item 5**), flatwasher (**Figure 1, Item 6**), and nut (**Figure 1, Item 7**).
4. Install dust cover (**Figure 1, Item 1**) on duct adapter (**Figure 1, Item 2**).

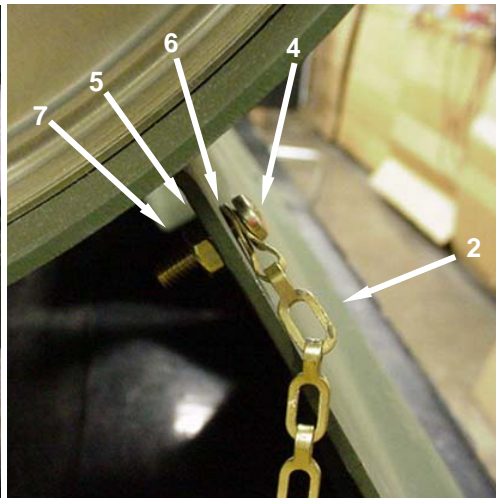
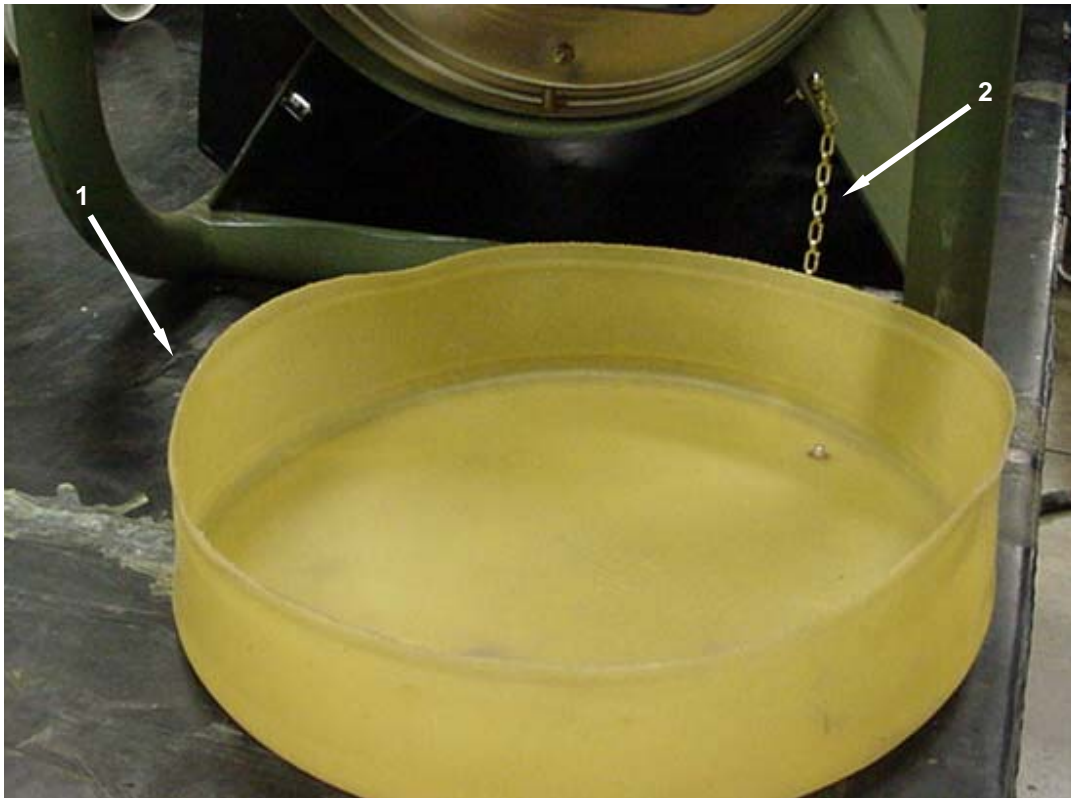

Figure 1. Dust Cover Assembly.

END OF WORK PACKAGE

**UNIT MAINTENANCE
SPACE HEATER, CONVECTIVE 60K BTU (SHC-60K)
NSN 4520-01-520-6477
COMBUSTION AIR BLOWER ASSEMBLY
REPLACE**

INITIAL SETUP:**Tools**

Tool Kit, General Mechanic's (Item 1, WP 0067 00)

Personnel Required

One

Materials/Parts

Baled Rag, General (Item 3, WP 0092 00)
Wire Markers (Item 19, WP 0092 00)

Equipment Condition

Heater shut down and all advisory lights off (WP 0006 00).
Fuel supply disconnected (WP 0006 00).
Battery disconnected (WP 0043 00).
Upper housing assembly removed (WP 0052 00).

REPLACE**Replace the Combustion Air Blower Assembly****WARNING**

Be sure to disconnect battery connector before performing any maintenance actions. Failure to do so may cause sparking or short circuits which might cause a fire or damage heater components.

1. Remove wrench (**Figure 1, Item 1**) and set aside.
2. Disconnect the combustion air blower assembly hose (**Figure 1, Item 2**) from the combustion air blower outlet (**Figure 1, Item 3**) by loosening the hose clamp (**Figure 1, Item 4**) and pulling the hose from the combustion air blower outlet.
3. Disconnect the combustion air blower electrical connector (**Figure 1, Item 5**).
4. Remove four screws (**Figure 1, Item 6**) connecting air blower assembly (**Figure 1, Item 7**) to bracket (**Figure 1, Item 8**).
5. Carefully push on bracket (**Figure 1, Item 8**) while lifting the combustion air blower assembly (**Figure 1, Item 7**) from the heater guiding the combustion air inlet (**Figure 1, Item 9**) through the side wall of the lower housing.
6. Connect electrical connectors (**Figure 1, Item 5**).
7. Lower the new combustion blower assembly (**Figure 1, Item 7**) into the lower housing, guiding the combustion air inlet (**Figure 1, Item 9**) through the hole in the side wall of the lower housing.
8. Orient the blower outlet port so that it is pointed up.
9. Install four screws (**Figure 1, Item 6**) and connect air blower assembly (**Figure 1, Item 7**) to bracket (**Figure 1, Item 8**).

10. Install the hose clamp (**Figure 1, Item 4**) and combustion air blower hose (**Figure 1, Item 2**) onto the outlet (**Figure 1, Item 3**) of the combustion air blower assembly. Tighten the hose clamp securely.
11. Return wrench (**Figure 1, Item 1**) to holding clip.
12. Turn on heater and verify that combustion blower assembly (**Figure 1, Item 6**) operates correctly.

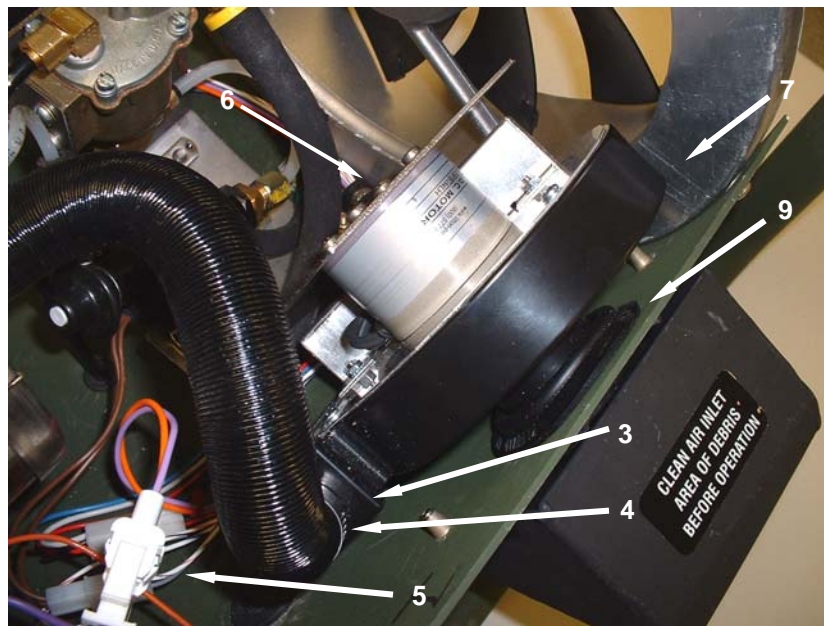
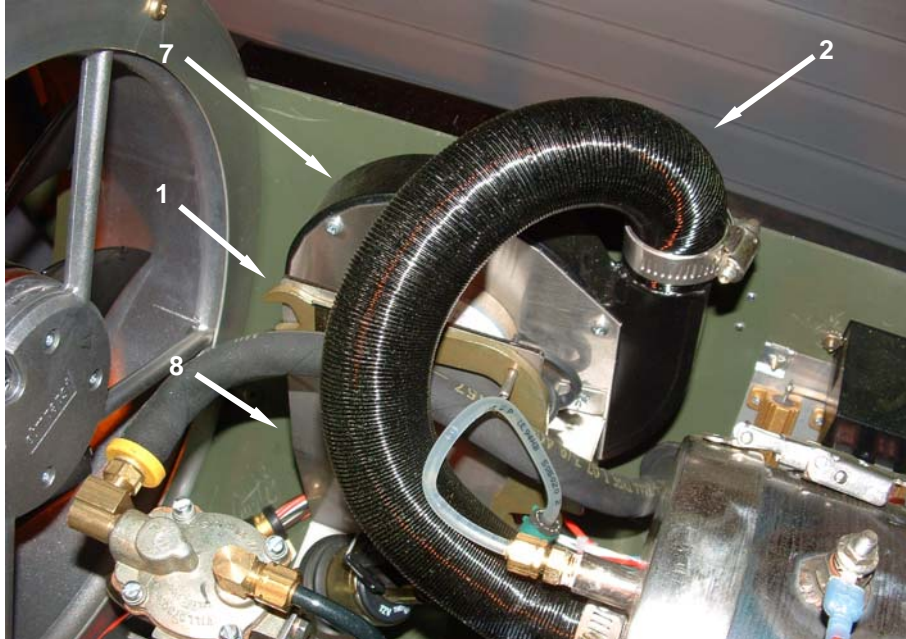

Figure 1. Combustion Air Blower Assembly.

END OF WORK PACKAGE

**UNIT MAINTENANCE
SPACE HEATER, CONVECTIVE 60K BTU (SHC-60K)
NSN 4520-01-520-6477
COMBUSTION AIR BLOWER HOSE
REPLACE**

INITIAL SETUP:**Tools**

Tool Kit, General Mechanic's (Item 1, WP 0067 00)

Personnel Required

One

Materials/Parts

None required

Equipment Condition

Heater shut down, cool, and all advisory lights off (WP 0006 00).
In-tent controller cable assembly disconnected from heater (WP 0006 00).
Fuel supply disconnected (WP 0006 00).
Battery disconnected (WP 0043 00).
Upper housing assembly removed (WP 0052 00).

REPLACE**Replace the Combustion Air Blower Hose****WARNING**

Be sure to disconnect battery connector before performing any maintenance actions. Failure to do so may cause sparking or short circuits which might cause a fire or damage heater components.

1. Disconnect the combustion air blower hose (**Figure 1, Item 1**) from the burner assembly (**Figure 1, Item 2**) by first loosening the hose clamp (**Figure 1, Item 3**) and sliding it onto the hose (**Figure 1, Item 1**).
2. Pull the end of the hose (**Figure 1, Item 1**) from the burner assembly (**Figure 1, Item 2**).
3. Disconnect the end of the combustion air blower hose (**Figure 1, Item 1**) connected to the combustion air blower assembly outlet (**Figure 1, Item 4**) by loosening the hose clamp (**Figure 1, Item 5**) and sliding it onto the hose (**Figure 1, Item 1**).
4. Remove the combustion air blower hose (**Figure 1, Item 1**) from the heater.
5. To install the combustion air blower hose (**Figure 1, Item 1**), connect the combustion air blower hose to the burner assembly (**Figure 1, Item 2**) by sliding it onto the hose inlet on the burner assembly (**Figure 1, Item 2**). Tighten the hose clamp (**Figure 1, Item 3**).
6. Slide the end of the combustion air blower hose onto the combustion air blower assembly outlet (**Figure 1, Item 4**). Slide the hose clamp (**Figure 1, Item 5**) into position and tighten.

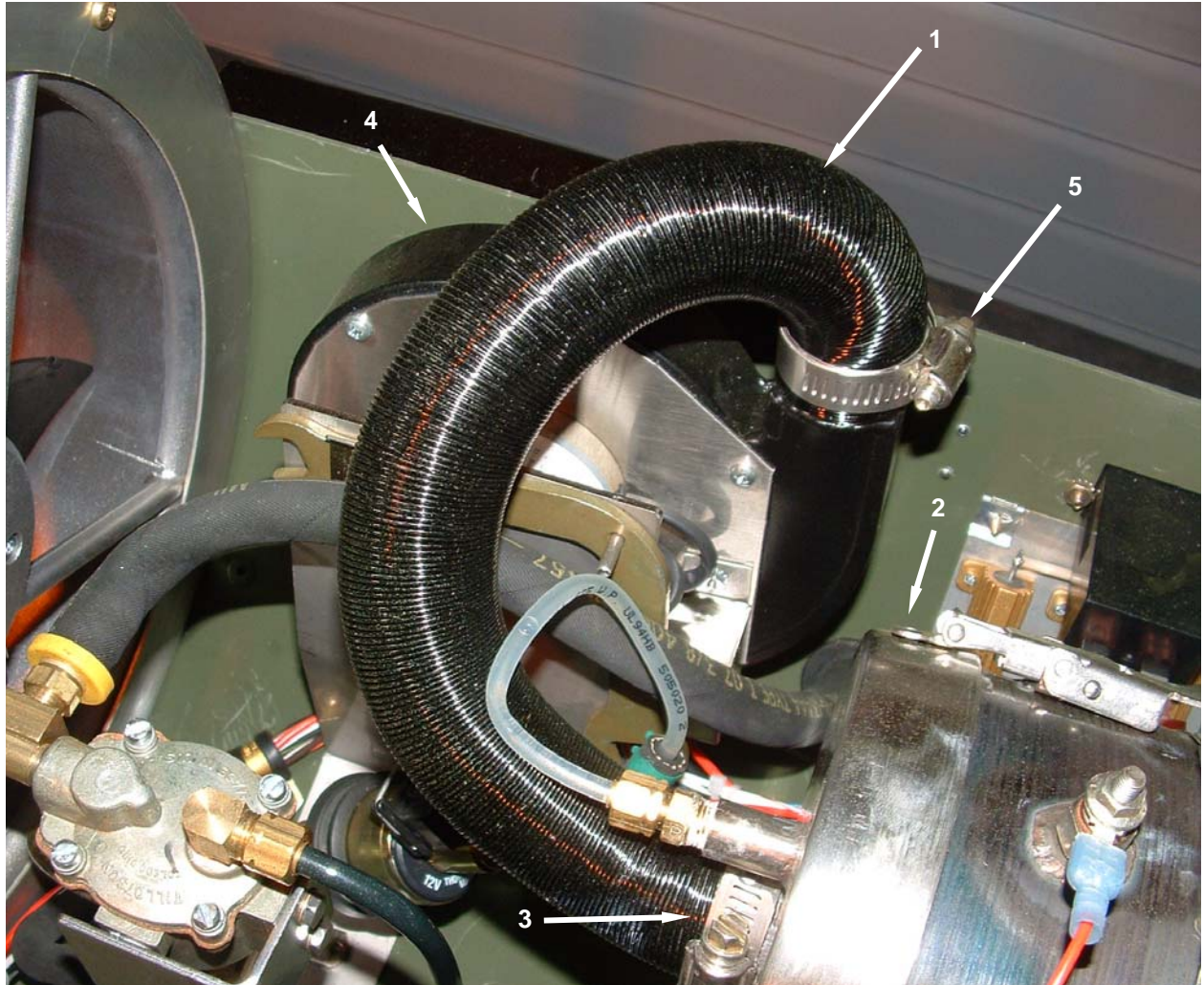

Figure 1. Combustion Air Blower Hose.

END OF WORK PACKAGE

**UNIT MAINTENANCE
SPACE HEATER, CONVECTIVE 60K BTU (SHC-60K)
NSN 4520-01-520-6477
UPPER HOUSING ASSEMBLY
SERVICE, REPAIR, REPLACE**

INITIAL SETUP:**Tools**

Tool Kit, General Mechanic's (Item 1, WP 0067 00)
Drill Set (Item 6, WP 0067 00)
Riveting Tool (Item 7, WP 0067 00)

Personnel Required

One

Materials/Parts

Lubricant, Silicone (Item 10, WP 0092 00)

Equipment Condition

Heater shut down, cool, and all advisory lights off (WP 0006 00).

SERVICE**Service the Upper Housing Assembly**

Lubricate slide portion (**Figure 1, Item 1**) and pivot (**Figure 1, Item 2**) of adjusting handle (**Figure 1, Item 3**) with silicone lubricant.

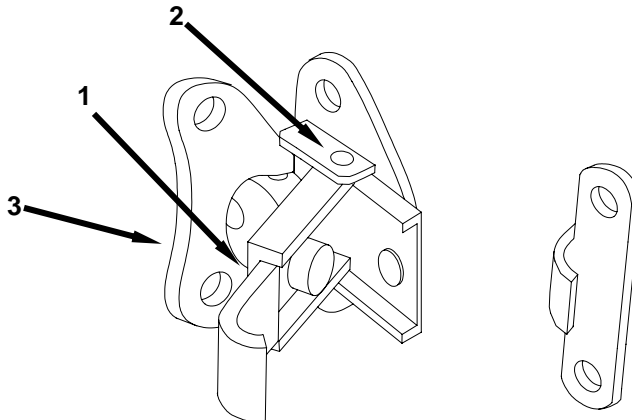

Figure 1. Lubricate.

REPAIR

Repair the Upper Housing Assembly

**WARNING**

Eye protection must be worn when performing this maintenance task. Proper eye protection will significantly reduce the risk of eye injury. Failure to observe this safety precaution could result in serious eye injury or blindness.

CAUTION

Select a drill sized the same size as the rivet hole or smaller. The correct size may be determined by comparing the drill to the replacement rivet. Using an oversized drill may enlarge the rivet hole, affecting alignment of the fastener.

1. To repair the upper housing assembly by replacing a keeper (**Figure 2, Item 1**) or catch (**Figure 2, Item 2**), first drill out the rivets (**Figure 2, Item 3**) retaining the fastener to the housing.

CAUTION

Ensure the flush head of the rivet faces the inside of the housing. Failure to do so will prevent the upper housing assembly from being secured properly, and may render the heater inoperable.

2. Install the keeper (**Figure 2, Item 1**) or catch (**Figure 2, Item 2**) to the housing using the riveting tool and rivets (**Figure 2, Item 3**).
3. Operate the keeper (**Figure 2, Item 1**) or catch (**Figure 2, Item 2**) to ensure that the halves align correctly.

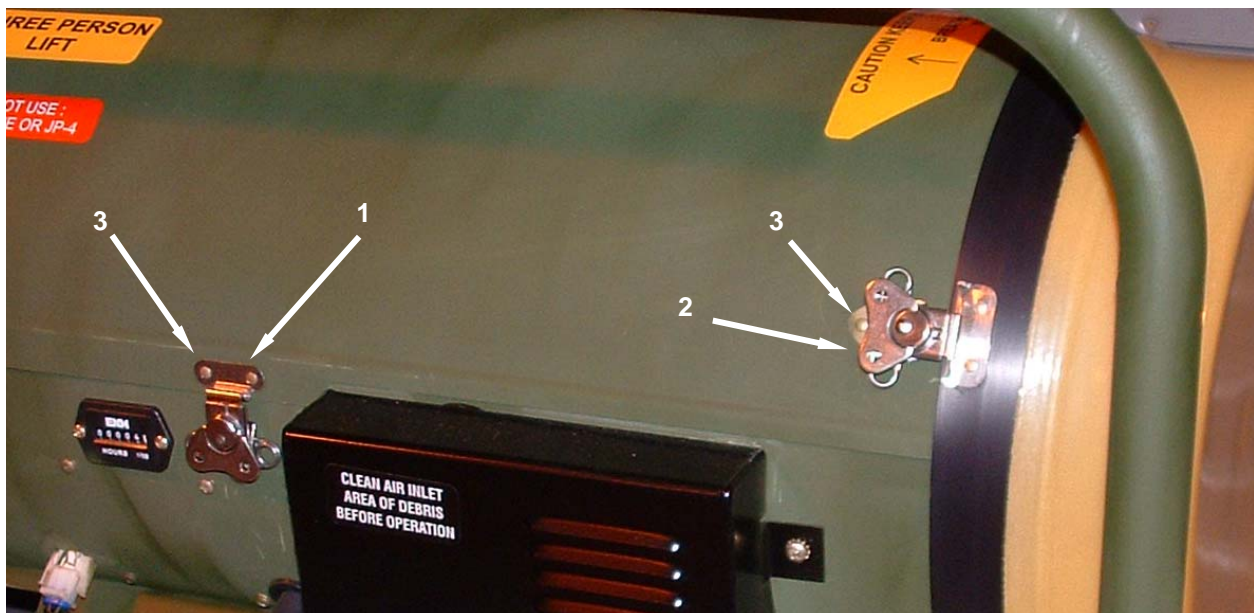

Figure 2. Repair the Upper Housing Assembly.

REPLACE**Replace the Upper Housing Assembly**

1. To replace the upper housing assembly (**Figure 3, Item 1**), remove the two dust covers (**Figure 3, Item 2**) and set aside.
2. Release the fasteners (**Figure 3, Item 3**) that secure the two duct adapters (**Figure 3, Item 4**) to the heater housing (**Figure 3, Item 5**). Remove the two duct adapters and set aside.
3. Release the four fasteners (**Figure 3, Item 6**) that secure the upper housing assembly (**Figure 3, Item 1**) to the lower housing assembly (**Figure 3, Item 7**).
4. Lift the upper housing assembly (**Figure 3, Item 1**) up and off the lower housing assembly (**Figure 3, Item 7**).
5. Install a new upper housing assembly (**Figure 3, Item 1**) and align with the lower housing assembly (**Figure 3, Item 7**). Align the four fasteners (**Figure 3, Item 6**) with their corresponding keeper plates.
6. Secure all four fasteners (**Figure 3, Item 6**).

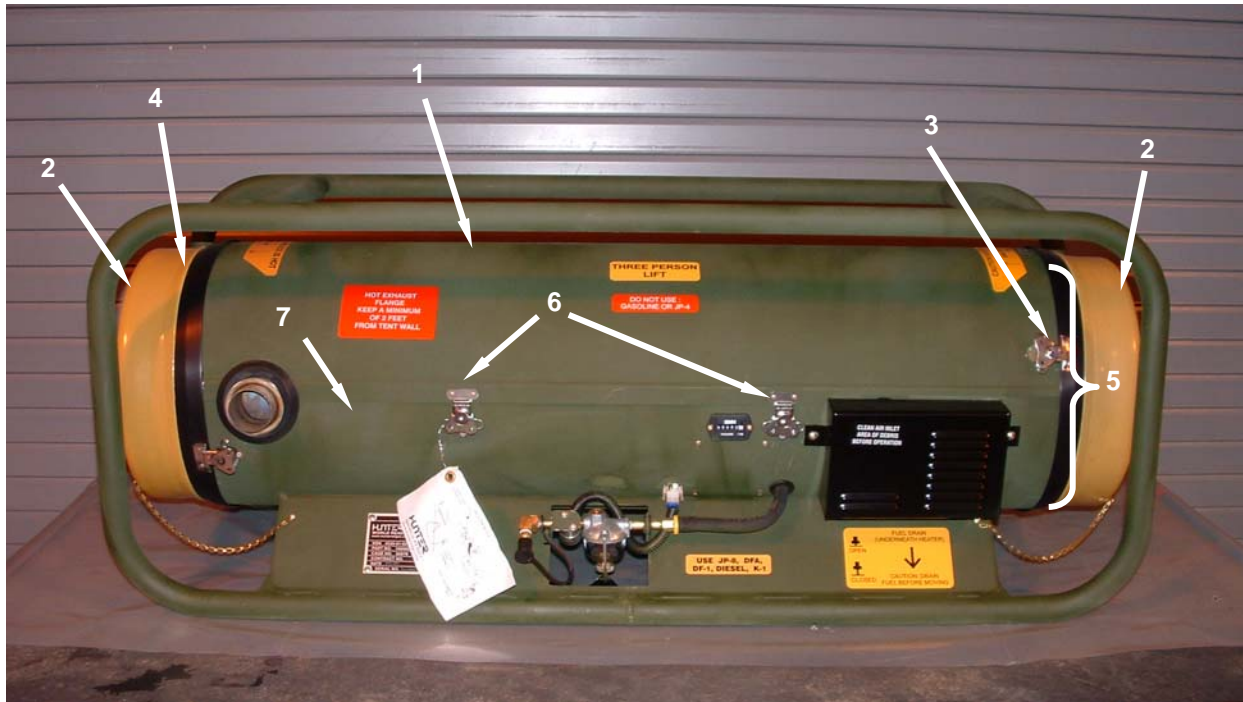

Figure 3. Upper Housing Assembly.

END OF WORK PACKAGE

**UNIT MAINTENANCE
SPACE HEATER, CONVECTIVE 60K BTU (SHC-60K)
NSN 4520-01-520-6477
EXHAUST GROMMET
REPLACE**

INITIAL SETUP:**Tools**

Tool Kit, General Mechanic's (Item 1, WP 0067 00)

Personnel Required

One

Materials/Parts

Lubricant, Silicone (Item 10, WP 0092 00)

Equipment Condition

Heater shut down, cool, and all advisory lights off (WP 0006 00).
In-tent controller assembly disconnected from heater (WP 0006 00).
Fuel source disconnected (WP 0006 00).
Battery disconnected (WP 0043 00).
Upper housing assembly removed (WP 0052 00).

REPLACE**Replace the Exhaust Grommet****WARNING**

Be sure to disconnect battery connector before performing any maintenance actions. Failure to do so may cause sparking or short circuits which might cause a fire or damage heater components.

1. Loosen the clamp (**Figure 1, Item 1**) that secures the burner assembly (**Figure 1, Item 2**). Loosening the clamp will permit the heat exchanger (**Figure 1, Item 3**) to be tilted upward to allow access to the grommet.
2. Tilt the end of the heat exchanger (**Figure 1, Item 3**) upward and slide the grommet (**Figure 1, Item 4**) up and out of the slotted recess on the lower housing assembly (**Figure 1, Item 5**).
3. Stretch the grommet (**Figure 1, Item 4**) over the ridge on the combustion exhaust pipe and slide the grommet off the combustion exhaust pipe (**Figure 1, Item 6**).
4. Install a new exhaust grommet (**Figure 1, Item 4**) by sliding the grommet over the combustion exhaust pipe (**Figure 1, Item 6**). Lift up slightly on the heat exchanger (**Figure 1, Item 4**) and engage the groove in the grommet over the sheet metal recess on the lower housing assembly (**Figure 1, Item 5**).
5. Press the exhaust grommet (**Figure 1, Item 4**) down firmly.
6. Retighten the clamp (**Figure 1, Item 1**) that secures the burner assembly (**Figure 1, Item 2**).

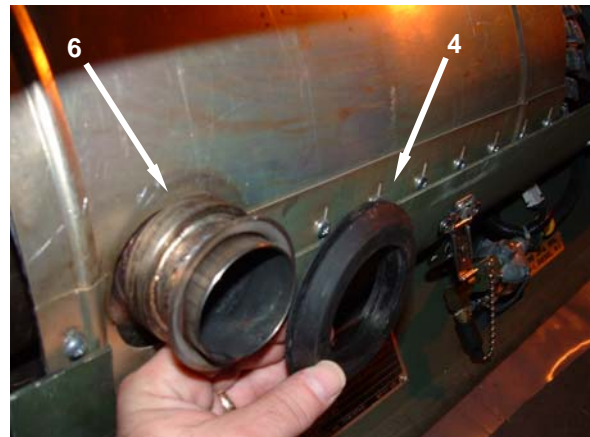
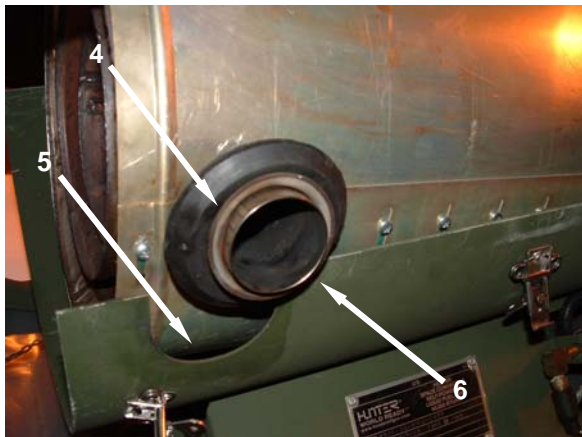
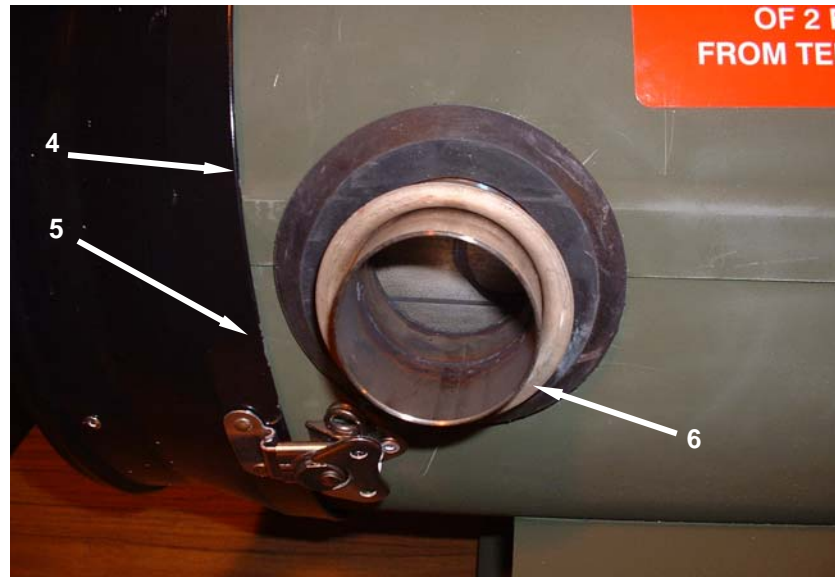
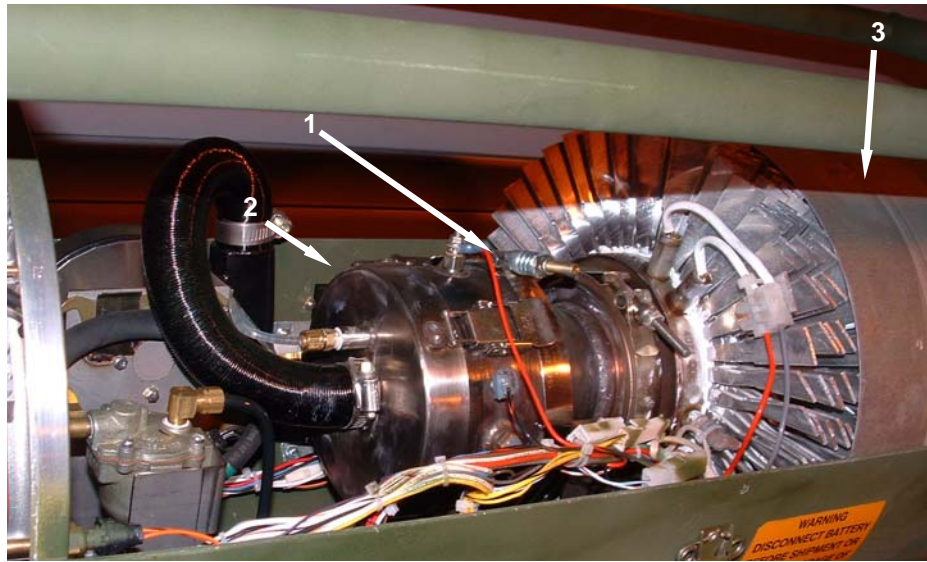

Figure 1. Exhaust Grommet.

END OF WORK PACKAGE

UNIT MAINTENANCE
SPACE HEATER, CONVECTIVE 60K BTU (SHC-60K)
NSN 4520-01-520-6477
HEATED AIR BLOWER ASSEMBLY
INSPECT, TEST, REPLACE

INITIAL SETUP:**Tools**

Tool Kit, General Mechanic's (Item 1, WP 0067 00)

Personnel Required

One

Materials/Parts

Wire Markers (Item 19, WP 0092 00)

Equipment Condition

Heater shut down, cool, and all advisory lights off (WP 0006 00).
 In-tent controller assembly disconnected from heater (WP 0006 00).
 Fuel supply disconnected (WP 0006 00).
 Battery disconnected (WP 0043 00).
 Upper housing assembly removed (WP 0052 00).

INSPECT**Inspect the Heated Air Blower Assembly**

WARNING

Be sure to disconnect battery connector before performing any maintenance actions. Failure to do so may cause sparking or short circuits which might cause a fire or damage heater components.

1. Inspect the heated air blower assembly (**Figure 1, Item 1**) for cracks, dents, or other damage that would prevent the heated air blower assembly from rotating freely.
2. Inspect the inlet (**Figure 1, Item 2**) and outlet (**Figure 1, Item 3**) side of the heated air blower assembly (**Figure 1, Item 1**) for any debris or blockages that would restrict the flow of air through the heater.
3. Start the heater, and observe the rotation of the heated air blower assembly fan during the power on self test (WP 0006 00, Table 1). Replace the heated air blower assembly if the fan does not spin.

TEST**Test the Heated Air Blower Assembly**

1. Set multimeter to measure resistance.
2. Tag and disconnect the harness wiring connected to the positive terminal (**Figure 1, Item 4**) and the negative terminal (**Figure 1, Item 5**).
3. Place probe No. 1 against positive terminal (**Figure 1, Item 4**) and probe No. 2 against negative terminal (**Figure 1, Item 5**). Normal meter indication is a minimum of 5.2 megaohms.

4. If meter reading indicates a short or an open circuit, replace heated air blower assembly (**Figure 1, Item 1**).
5. Reconnect the harness wiring as tagged.
6. Start the heater.
7. Observe the rotation of the heated air blower assembly fan during the power on self test (WP 0006 00, Table 1).
8. If the heated air blower assembly fan does not spin, replace it IAW this work package.

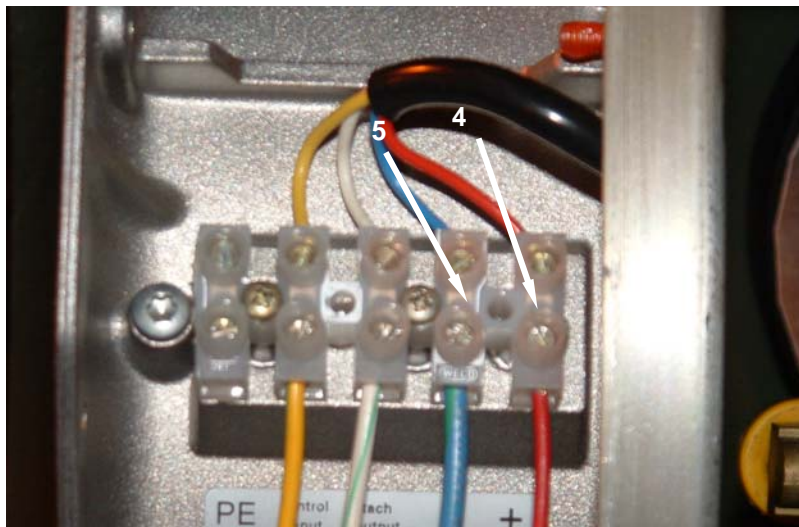

Figure 1. Heated Air Blower Assembly.

REPLACE**Replace the Heated Air Blower Assembly**

1. Remove air inlet cover (**Figure 2, Item 1**).
2. Remove all spare parts that may be stored on the heated air blower assembly (**Figure 2, Item 2**) and set aside.
3. Remove three screws (**Figure 2, Item 3**) that secure the heated air blower assembly (**Figure 2, Item 2**) to lower assembly (**Figure 2, Item 4**).
4. Tag wires (**Figure 2, Item 5**) on both sides of terminal connector (**Figure 2, Item 6**) to ensure proper replacement.
5. Loosen terminal screws inside the air blower assembly connectors (**Figure 2, Item 6**); disconnect wires (**Figure 2, Item 5**) from heated air blower assembly. Pull wires from the heated air blower assembly (**Figure 2, Item 2**).
6. Disconnect the inlet air temperature sensor (**Figure 2, Item 7**).
7. Remove the heated air blower assembly (**Figure 2, Item 2**).
8. Position the heater air blower assembly (**Figure 2, Item 2**), over the three holes on the lower assembly (**Figure 2, Item 4**).
9. Pull wires (**Figure 2, Item 5**) through the heated air blower assembly (**Figure 2, Item 2**).
10. Install the heated air blower assembly (**Figure 2, Item 2**) to lower housing assembly (**Figure 2, Item 4**), and retain with three screws (**Figure 2, Item 3**).

CAUTION

Ensure air blower assembly wiring is protected by the rubber grommet installed in the body of the air blower assembly. Improper installation may cause wires to chafe and short circuit, rendering the heater inoperable.

11. Place wires (**Figure 2, Item 5**) inside the air blower assembly connectors (**Figure 2, Item 6**); tighten terminal screws to secure.
12. Reconnect the inlet air temperature sensor (**Figure 2, Item 7**).
13. Install the air inlet cover (**Figure 2, Item 1**).
14. Refit any spare parts that may have been removed, install upper housing, reinstall duct adapters, and verify normal operation IAW WP 0006 00.

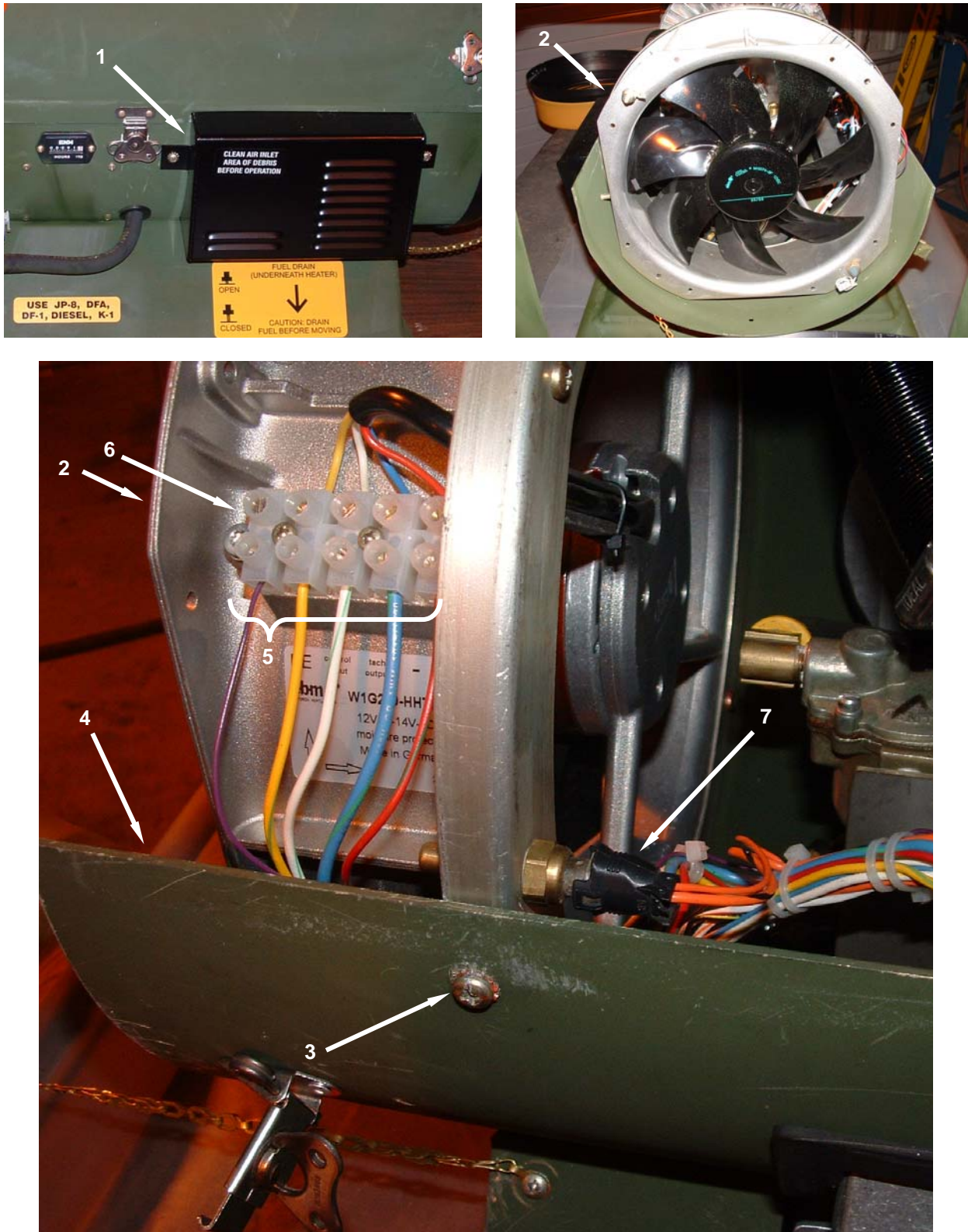

Figure 2. Replace the Heated Air Blower Assembly.

END OF WORK PACKAGE

UNIT MAINTENANCE
SPACE HEATER, CONVECTIVE 60K BTU (SHC-60K)
NSN 4520-01-520-6477
INLET AIR TEMPERATURE SENSOR
REPLACE

INITIAL SETUP:**Tools**

Tool Kit, General Mechanic's (Item 1, WP 0067 00)

Personnel Required

One

Materials/Parts

None required

Equipment Condition

Heater shut down, cool, and all advisory lights off (WP 0006 00).

In-tent controller assembly disconnected from heater (WP 0006 00).

Fuel supply disconnected (WP 0006 00).

Battery disconnected (WP 0043 00).

Upper housing assembly removed (WP 0052 00).

REPLACE**WARNING**

Be sure to disconnect battery connector before performing any maintenance procedures. Failure to do so may cause sparking or short circuits which might cause a fire or damage heater components.

Replace the Inlet Air Temperature Sensor

1. Remove connector (**Figure 1, Item 1**) at end.

CAUTION

The wrench supplied with the heater cannot be used to perform this maintenance task. Attempting to use the supplied wrench may result in damage to the wrench or the sensor.

2. Remove inlet air temperature sensor (**Figure 1, Item 2**).
3. Install new inlet air temperature sensor (**Figure 1, Item 2**).
4. Reconnect connector (**Figure 1, Item 1**).

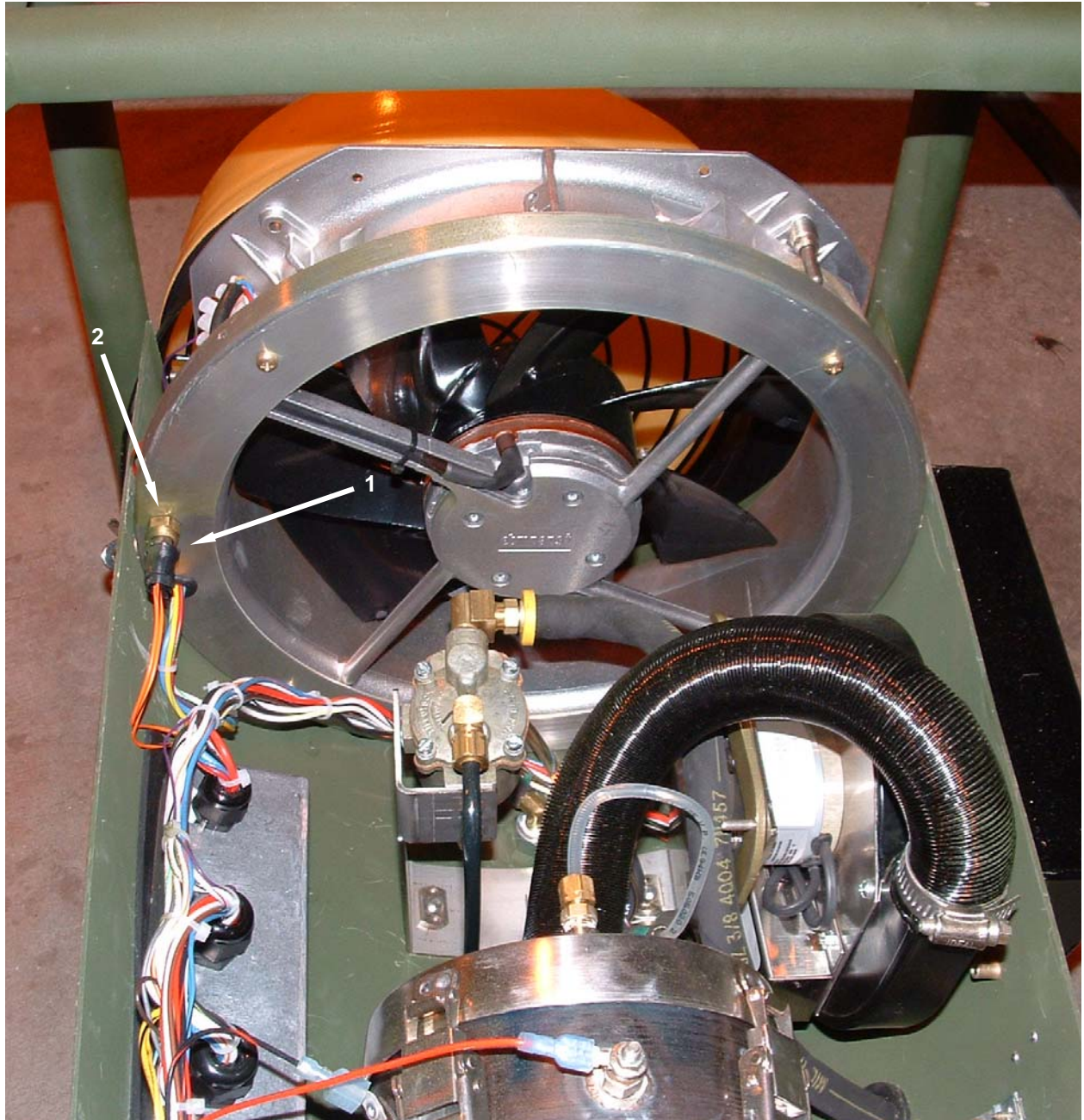

Figure 1. Inlet Air Temperature Sensor.

END OF WORK PACKAGE

UNIT MAINTENANCE
SPACE HEATER, CONVECTIVE 60K BTU (SHC-60K)
NSN 4520-01-520-6477
FUEL PUMP
TEST, REPLACE

INITIAL SETUP:**Tools**

Tool Kit, General Mechanic's (Item 1, WP 0067 00)

Personnel Required

One

Materials/Parts

Mat, Petroleum Absorbent (Item 11, WP 0092 00)
Tray, Petroleum Absorbent (Item 18, WP 0092 00)

Equipment Condition

Heater shut down, cool, and all advisory lights off (WP 0006 00).
In-tent controller assembly disconnected from heater (WP 0006 00).
Fuel supply disconnected (WP 0006 00).
Battery disconnected (WP 0043 00).
Upper housing assembly removed (WP 0052 00).

TEST**Test the Fuel Pump****WARNING**

Be sure to disconnect battery connector before performing any maintenance actions. Failure to do so may cause sparking or short circuits which might cause a fire or damage heater components.

CAUTION

Do not remove the wire clamp. It will stay in place after release of the electrical connector.

1. Push (do not pull) on the wire clamp (**Figure 1, Item 1**) to release the electrical connector (**Figure 1, Item 2**), and disconnect the electrical connector for the fuel pump (**Figure 1, Item 3**).
2. Test for continuity with an ohmmeter. A correct reading should read 5 ohms, +/- 2 ohms. If it has a reading other than specified, replace an open or shorted fuel pump (**Figure 1, Item 3**).
3. Reconnect the electrical connector (**Figure 1, Item 2**), and retain in place by pushing down on the wire clamp (**Figure 1, Item 1**).

NOTE

Figure 1 shows the SHC-60K in a partially disassembled state in order to clearly depict the fuel pump and its connections.

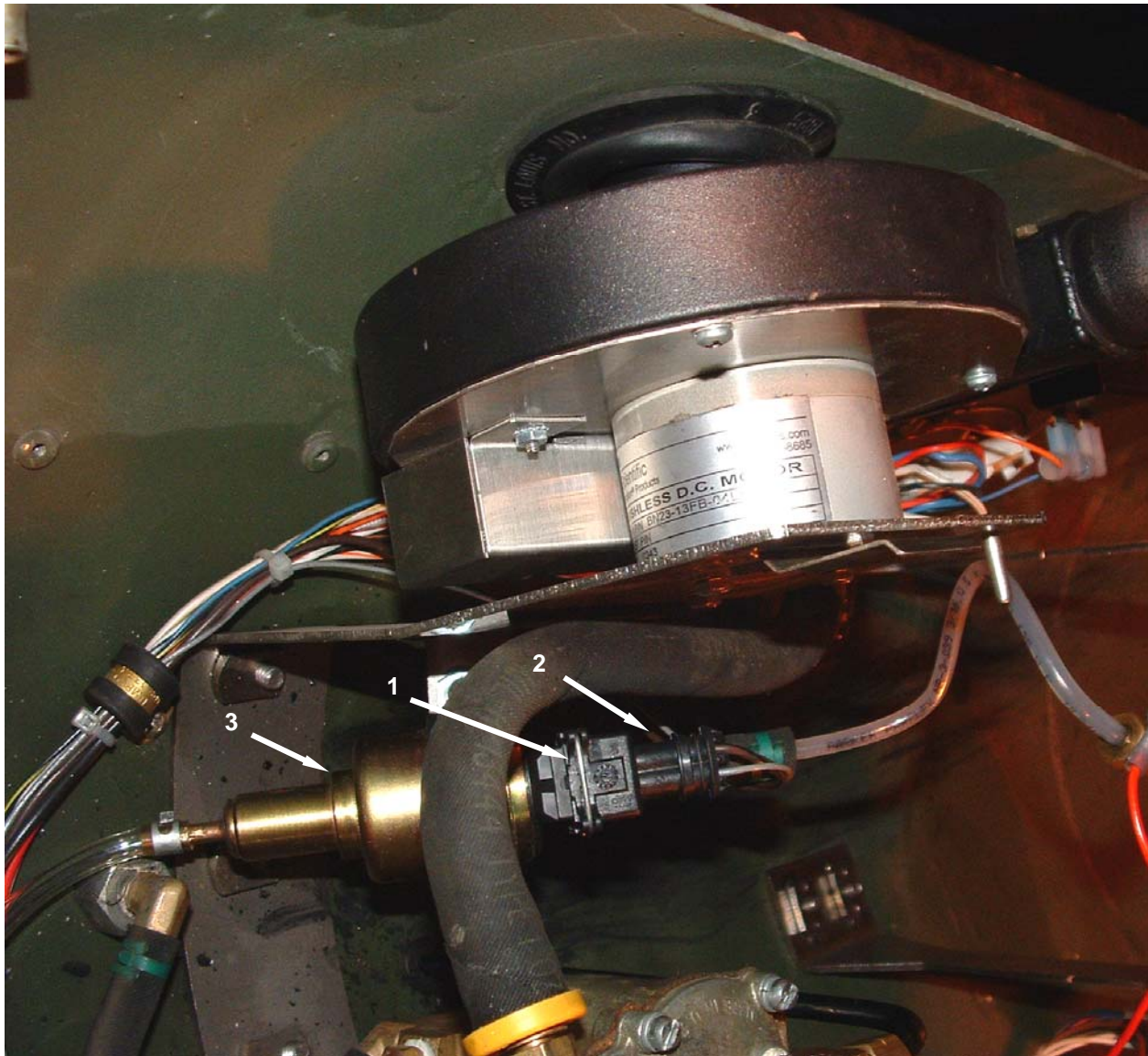

Figure 1. Test the Fuel Pump.

REPLACE**Replace the Fuel Pump and Fuel Pump Hoses****WARNING**

Be sure to disconnect battery connector before performing any maintenance actions. Failure to do so may cause sparking or short circuits which might cause a fire or damage heater components.

**WARNING**

Fuels are toxic. Wear eye/face protection, impervious hand protection, avoid contact with skin and clothes, and don't breathe vapors. The use of protective gloves will significantly reduce the risks of exposure by prevent contact with skin. If contact with eyes or skin is made, immediately flush with clean water and get medical aid for eyes. If contact with clothing or skin is made, immediately remove contaminated clothing and clean skin with mild soap or cleanser and flush with clean water. Failure to observe these precautions could result in exposure to fuel, resulting in serious illness.

NOTE

Manage and dispose of fuel and fuel absorbent pads or wipes in accordance with appropriate state, local, and installation environmental regulations.

1. Place a petroleum absorbent mat under the heater. Open the drain valve (**Figure 2, Item 1**) and allow fuel to drain into a clean container. Close drain.
2. Loosen the hose clamps (**Figure 2, Item 2**) retaining the combustion air blower hose (**Figure 2, Item 3**), and remove the combustion air blower hose.
3. Place a petroleum absorbent mat under the fuel pump (**Figure 2, Item 4**).

CAUTION

Do not pull the wire clip securing the electrical quick disconnect to the fuel pump.

4. Push, do not pull, on the wire clamp (**Figure 2, Item 5**) to release the electrical connector (**Figure 2, Item 6**), and disconnect the electrical connector for the fuel pump (**Figure 2, Item 4**).
5. Remove the screw (**Figure 2, Item 7**) that secures the fuel pump bracket (**Figure 2, Item 8**) to the lower housing assembly (**Figure 2, Item 9**).
6. Loosen the compression fitting retaining the fuel pump outlet hose (**Figure 2, Item 10**) to the burner (**Figure 2, Item 11**), and remove the hose from the burner.
7. Use pliers to release the hose clamp, and remove the fuel pump inlet hose (**Figure 2, Item 12**) from the float assembly (**Figure 2, Item 13**).

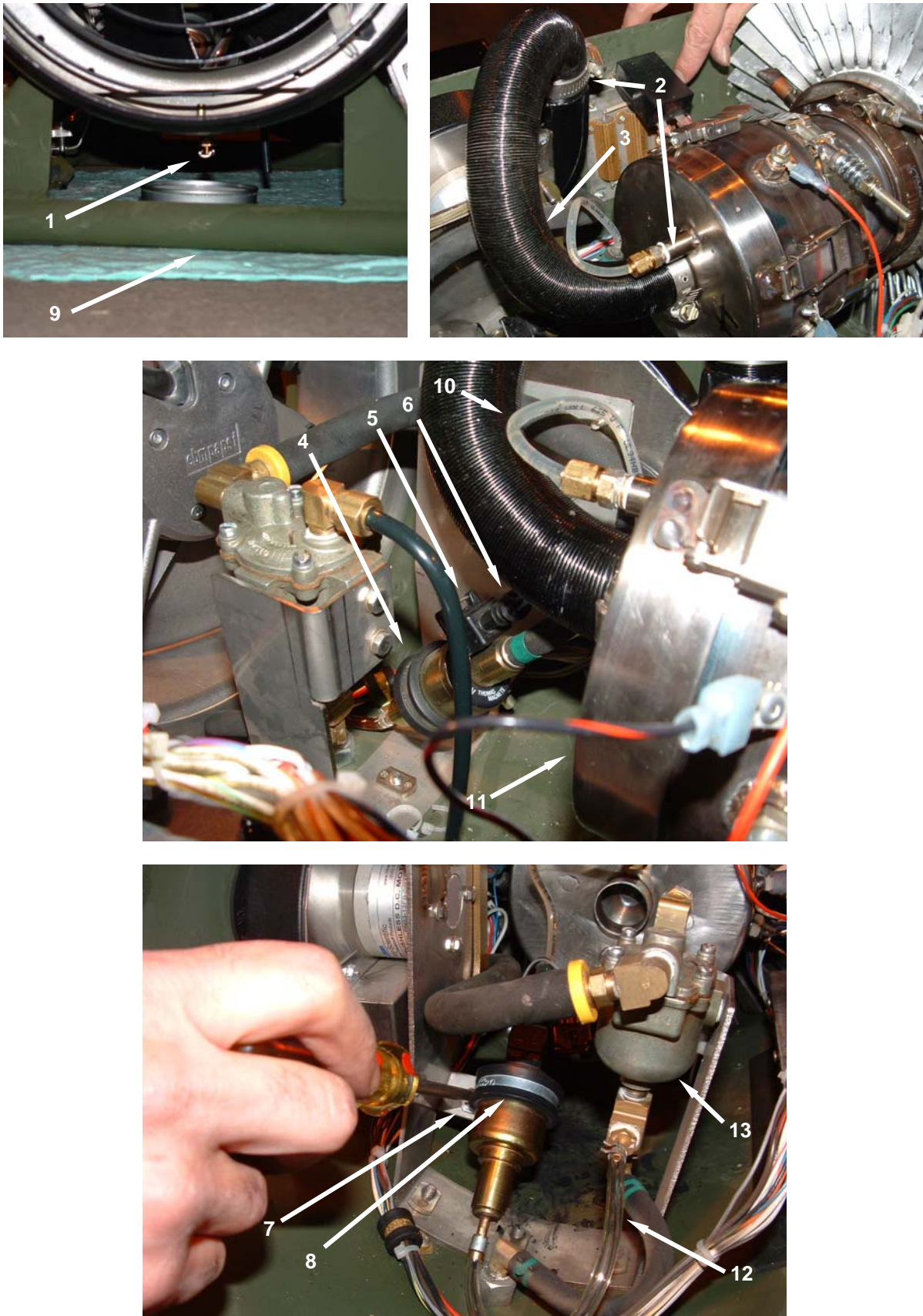

Figure 2. Replace the Fuel Pump and Fuel Pump Hoses - Disassembly.

8. Remove the fuel pump bracket (**Figure 3, Item 1**) and screw (**Figure 3, Item 2**) from the fuel pump (**Figure 3, Item 3**) and set aside.

NOTE

The replacement fuel pump is supplied with the hoses attached. If the fuel hoses require replacement, proceed with the next step. If replacing the fuel pump, proceed to step 16.

If fuel hoses are being replaced, they should be replaced as a set.

9. Squeeze the hose clamp on the outlet hose (**Figure 3, Item 4**) of the fuel pump (**Figure 3, Item 3**) and pull the outlet hose off of the barbed fitting on the fuel pump. Drain any fuel onto a petroleum absorbent mat or tray.
10. Use pliers to release the hose clamp at the connection of the black hose (**Figure 3, Item 5**) and the clear tube (**Figure 3, Item 6**) on the outlet hose (**Figure 3, Item 4**), and separate the two hoses.
11. While working on petroleum absorbent material, squeeze the hose clamp and remove the fuel line (**Figure 3, Item 7**) leading to the inlet end of the fuel pump (**Figure 3, Item 3**).
12. Retain all hose clamps from the fuel pump hoses.
13. Install the replacement fuel line (**Figure 3, Item 7**) to the inlet end of the fuel pump (**Figure 3, Item 3**). Ensure the hose is secure on the barbed fitting.
14. Assemble the outlet hose (**Figure 3, Item 4**) by inserting the clear tubing (**Figure 3, Item 6**) into the black hose (**Figure 3, Item 5**) approximately $\frac{1}{2}$ inch (13 mm), and retain in place with a hose clamp.
15. Install the outlet hose (**Figure 3, Item 4**) at the outlet end of the fuel pump (**Figure 3, Item 3**). Ensure the hose is secure on the barbed fitting.
16. Slide the fuel pump bracket (**Figure 3, Item 1**) over the fuel pump.

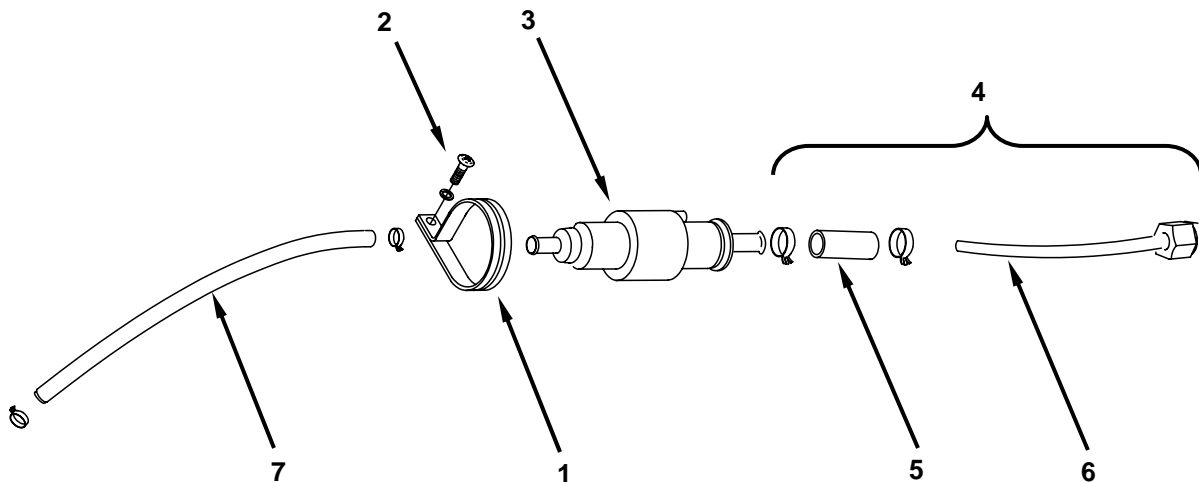

Figure 3. Replace the Fuel Pump and Fuel Pump Hoses – Disassemble Hoses.

17. Position the fuel pump bracket (**Figure 4, Item 1**) over the hole in the lower housing assembly and install the screw (**Figure 4, Item 2**). Tighten securely.
18. Connect the fuel pump inlet hose (**Figure 4, Item 3**) to the float assembly (**Figure 4, Item 4**).
19. Connect the fuel pump outlet hose (**Figure 4, Item 5**) to the compression fitting connection on the burner (**Figure 4, Item 6**). Tighten the compression fitting ¼ turn past hand tight.
20. Reconnect the electrical connector (**Figure 4, Item 7**).
21. Install combustion air blower fan hose (**Figure 5, Item 1**) and tighten hose clamps (**Figure 5, Item 2**).
22. Install the upper housing and the duct adapters. Operate IAW WP 0006 00, and monitor for normal operation.

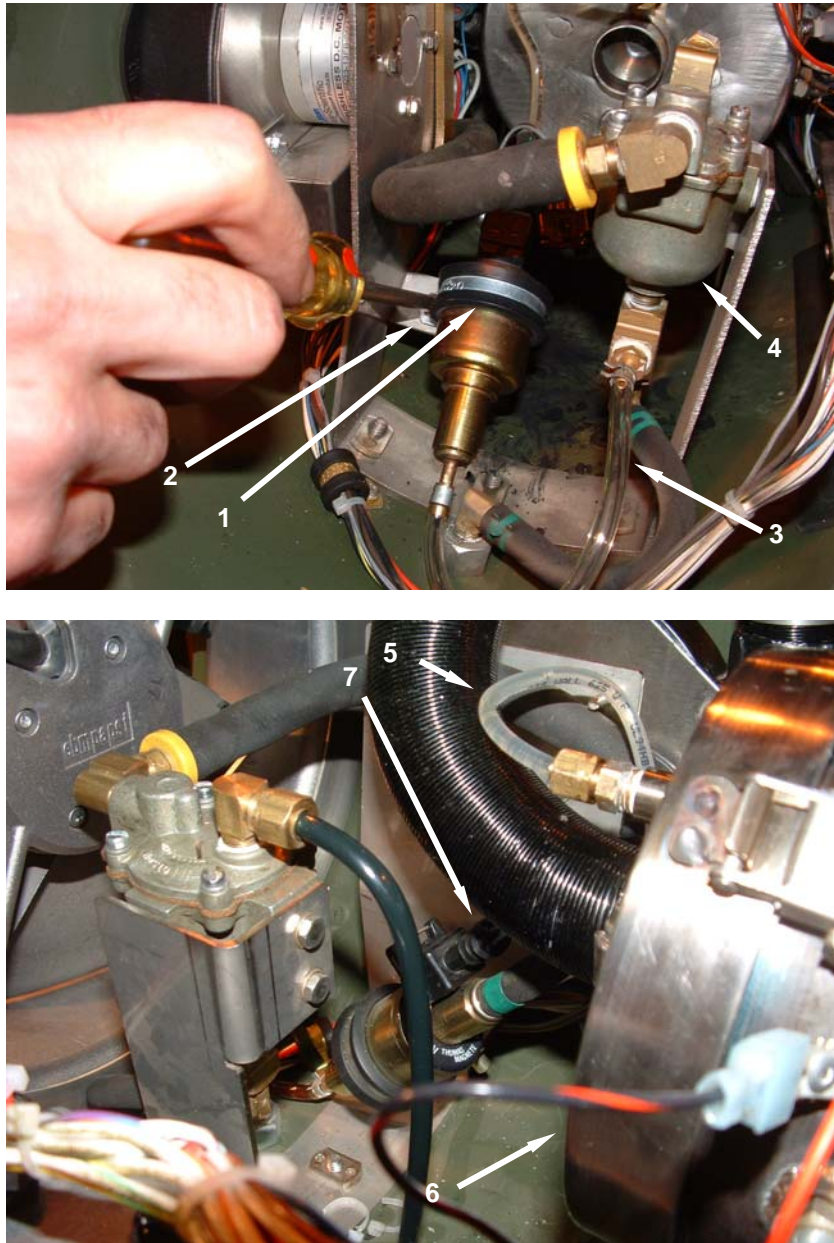

Figure 4. Replace Fuel Pump Assembly.

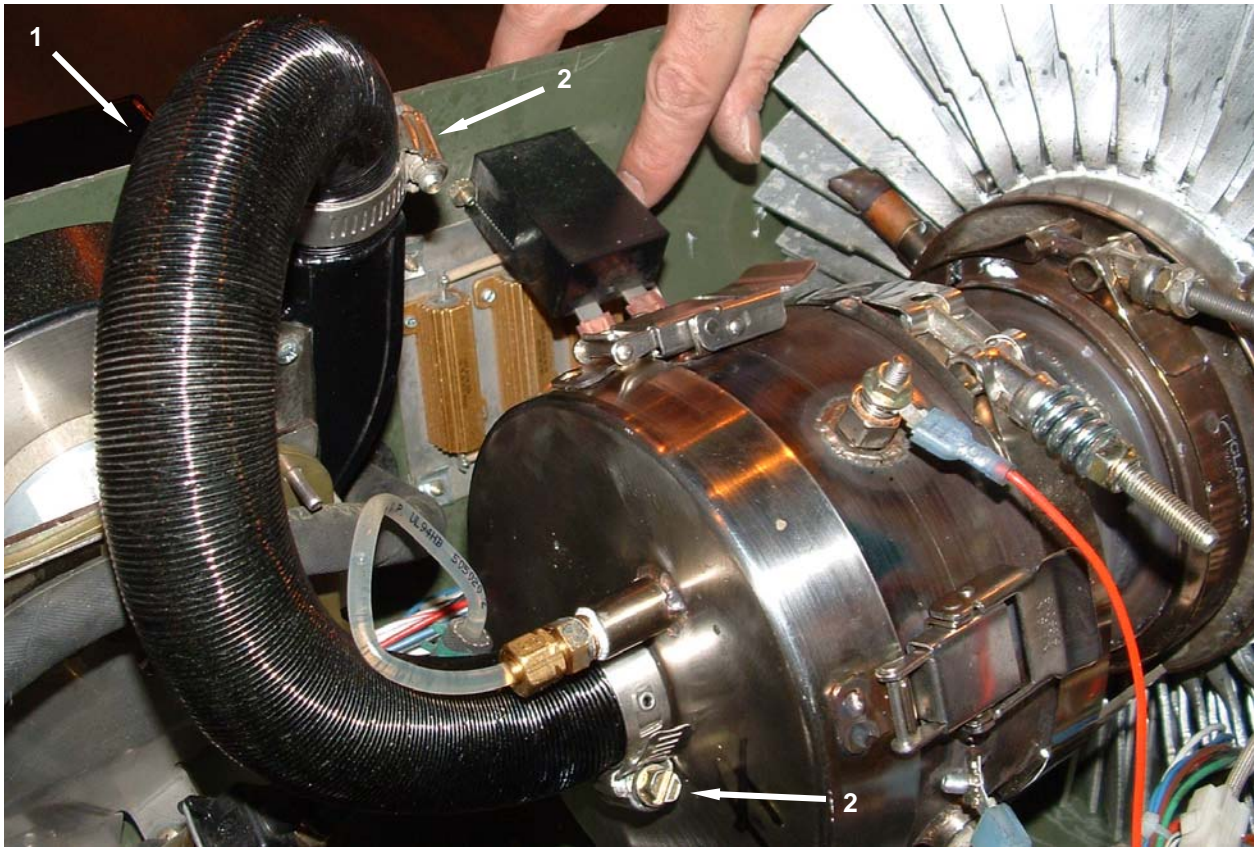

Figure 5. Replace the Fuel Pump Assembly.

END OF WORK PACKAGE

**UNIT MAINTENANCE
SPACE HEATER, CONVECTIVE 60K BTU (SHC-60K)
NSN 4520-01-520-6477
MANUAL THERMOSTAT RESET SWITCH
TEST, REPLACE**

INITIAL SETUP:**Tools**

Tool Kit, General Mechanic's (Item 1, WP 0067 00)

Personnel Required

Two

Materials/Parts

None required

Equipment Condition

Heater shut down, cool, and all advisory lights off (WP 0006 00).

In-tent controller assembly disconnected from heater (WP 0006 00).

Fuel supply disconnected (WP 0006 00).

Battery disconnected (WP 0043 00).

TEST**Test the Manual Thermostat Reset Switch**

1. Remove rubber protector (**Figure 1, Item 1**) protecting the manual thermostat reset switch (**Figure 1, Item 2**).
2. Remove connectors (**Figure 1, Item 3**) attached to the spade legs (**Figure 1, Item 4**).
3. Press the reset button (**Figure 1, Item 5**).
4. Use a multimeter to test for continuity between the two spade legs (**Figure 1, Item 4**). Replace an open switch (**Figure 1, Item 2**).
5. Use a multimeter to test for short to ground at each spade leg (**Figure 1, Item 4**). Replace a shorted switch (**Figure 1, Item 2**).
6. Attach the connectors (**Figure 1, Item 3**) firmly to the spade legs.
7. Install rubber protector (**Figure 1, Item 1**).



Figure 1. Test the Manual Thermostat Reset Switch.

REPLACE**Replace the Manual Thermostat Reset Switch****WARNING**

Be sure to disconnect battery connector before performing any maintenance procedures. Failure to do so may cause sparking or short circuits which might cause a fire or damage heater components.

1. Remove rubber protector (**Figure 2, Item 1**) protecting the manual thermostat reset switch (**Figure 2, Item 2**).
2. Remove connectors (**Figure 2, Item 3**) attached to the spade legs.
3. Remove two screws (**Figure 2, Item 4**) securing manual thermostat reset switch (**Figure 2, Item 2**).
4. Remove manual thermostat reset switch (**Figure 2, Item 2**).
5. Install new manual thermostat reset switch and secure with two screws (**Figure 2, Item 4**).
6. Attach the connectors (**Figure 2, Item 3**) firmly to the spade legs.
7. Install rubber protector (**Figure 2, Item 1**).



Figure 2. Replace the Manual Thermostat Reset Switch.

END OF WORK PACKAGE

**UNIT MAINTENANCE
SPACE HEATER, CONVECTIVE 60K BTU (SHC-60K)
NSN 4520-01-520-6477
INTERNAL FUEL LINES
REPLACE**

INITIAL SETUP:**Tools**

Tool Kit, General Mechanic's (Item 1, WP 0067 00)

Personnel Required

One

Materials/Parts

Baled Rag, General (Item 3, WP 0092 00)
Mat, Petroleum Absorbent (Item 11, WP 0092 00)
Tie, Wire (Item 17, WP 0092 00)
Wire Markers (Item 19, WP 0092 00)

Equipment Condition

Heater shut down, cool, and all advisory lights off (WP 0006 00).
In-tent controller assembly disconnected from heater (WP 0006 00).
Fuel supply disconnected (WP 0006 00).
Battery disconnected (WP 0043 00).
Upper housing assembly removed (WP 0052 00).

REPLACE**Replace Internal Fuel Lines****WARNING**

Be sure to disconnect battery connector before performing any maintenance procedures. Failure to do so may cause sparking or short circuits which might cause a fire or damage heater components.

**WARNING**

Fuels are toxic. Wear eye/face protection, impervious hand protection, avoid contact with skin and clothes, and don't breathe vapors. The use of protective gloves will significantly reduce the risks of exposure by prevent contact with skin. If contact with eyes or skin is made, immediately flush with clean water and get medical aid for eyes. If contact with clothing or skin is made, immediately remove contaminated clothing and clean skin with mild soap or cleanser and flush with clean water. Failure to observe these precautions could result in exposure to fuel, resulting in serious illness.

NOTE

Manage and dispose of fuel and fuel absorbent pads or wipes in accordance with appropriate state, local, and installation environmental regulations.

NOTE

There are two internal fuel lines covered in this work package. A formed plastic vent line (**Figure 1, Item 1**) is fitted to the top of the float assembly, and a rubber fuel drain line (**Figure 1, Item 2**) extends from the bottom of the float assembly through the lower housing assembly, terminated by a drain cock.

1. Place a petroleum absorbent mat under the heater in the area of the fuel lines.
2. To remove the plastic vent line (**Figure 1, Item 1**), unscrew the compression fitting (**Figure 1, Item 3**), and remove the vent from the grommet (**Figure 1, Item 4**) in the lower housing assembly.
3. To install the vent line (**Figure 1, Item 1**), insert the open end of the vent into the grommet (**Figure 1, Item 4**) in the lower housing assembly, and then connect and tighten the compression fitting (**Figure 1, Item 3**) to the float assembly.
4. To remove the drain line (**Figure 1, Item 2**), use pliers to squeeze the hose clamp (**Figure 1, Item 5**) at each end of the drain line, taking care not to spill the fuel that may be contained in the line. Drain the fuel into an approved container. Wipe up any fuel that may spill in the lower housing assembly or on any of the components.
5. Remove the drain line (**Figure 1, Item 2**) from the heater.
6. Use pliers to squeeze the hose clamps (**Figure 1, Item 5**), and remove the hose clamps from the drain line (**Figure 1, Item 2**).
7. Use pliers to squeeze the hose clamps (**Figure 1, Item 5**), and install the hose clamps on the replacement drain line (**Figure 1, Item 2**).

NOTE

It is not necessary to compress the hose clamp when installing the replacement drain line.

8. Apply a small amount of fuel to the hose openings, and install the replacement drain line (**Figure 1, Item 2**).
9. Repeat for fitting on opposite end of drain line (**Figure 1, Item 2**).
10. Install the upper housing and the duct adapters. Operate IAW WP 0006 00, and monitor for normal operation.

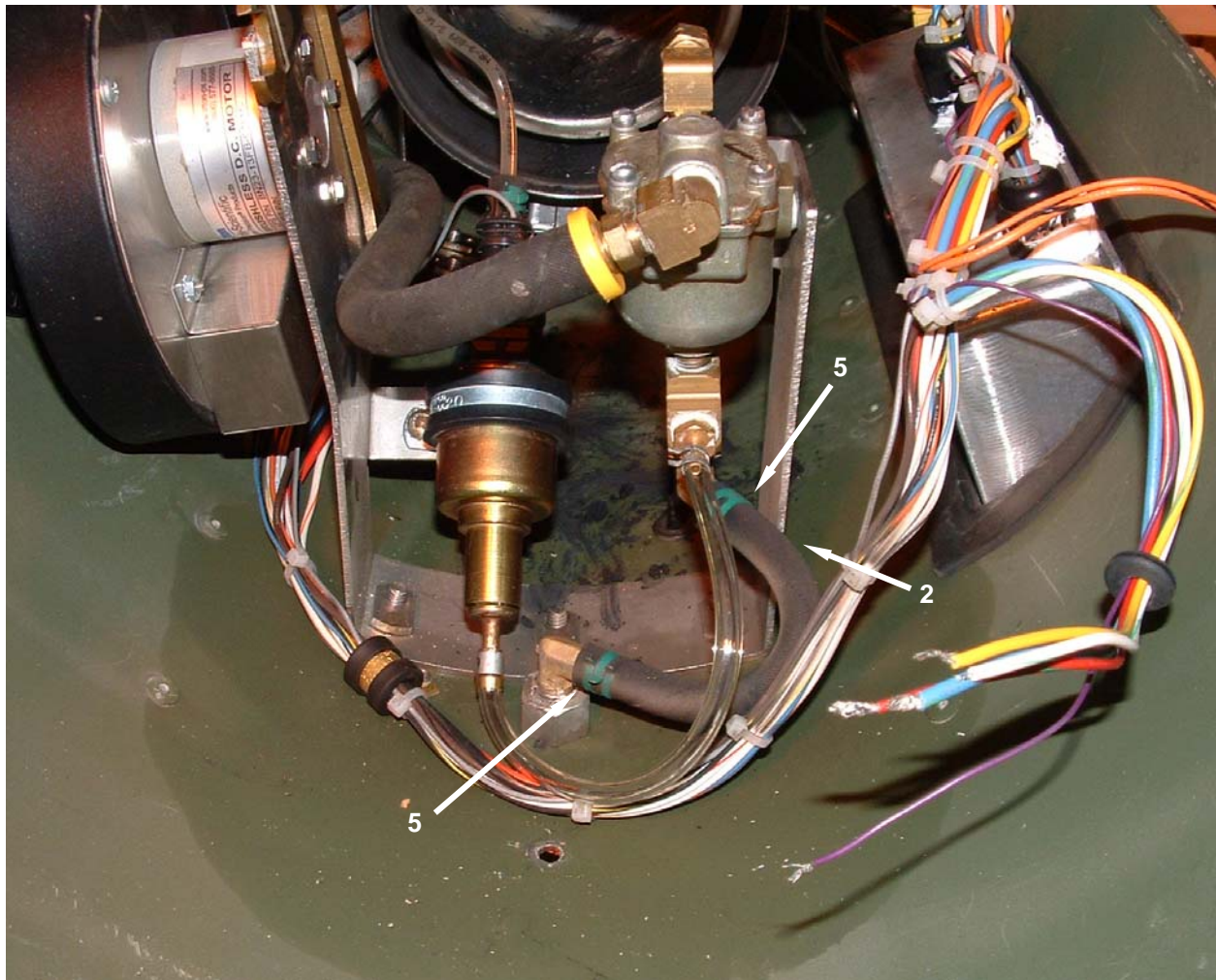
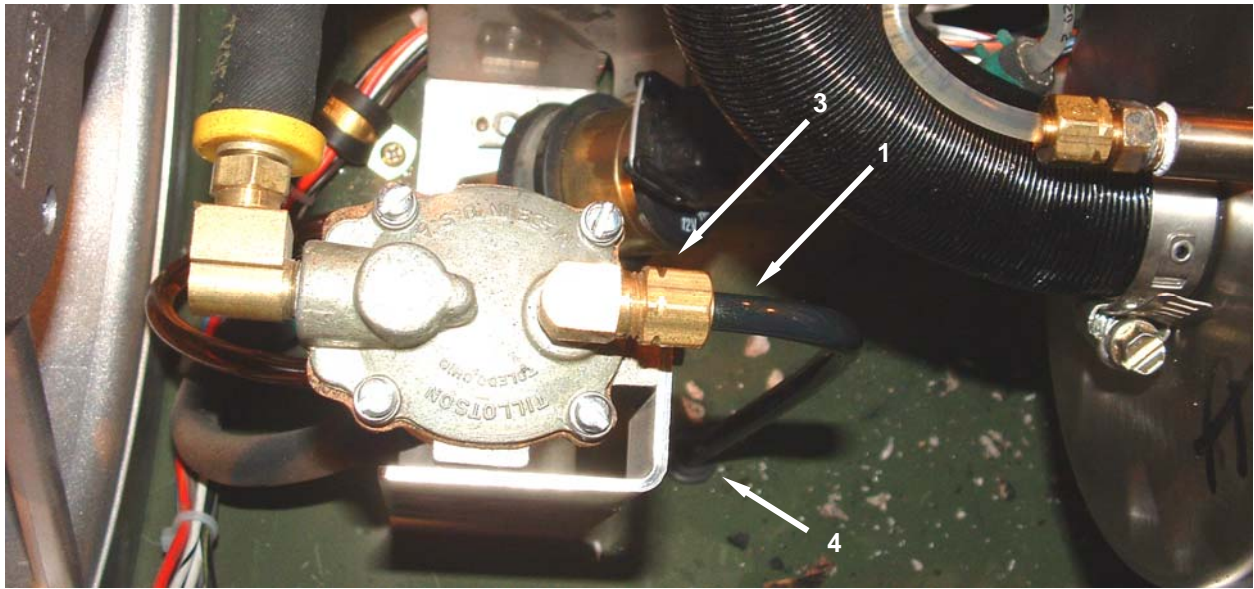

Figure 1. Replace Internal Fuel Lines.

END OF WORK PACKAGE

**UNIT MAINTENANCE
SPACE HEATER, CONVECTIVE 60K BTU (SHC-60K)
NSN 4520-01-520-6477
FLOAT ASSEMBLY
SERVICE, REPLACE**

INITIAL SETUP:**Tools**

Tool Kit, General Mechanic's (Item 1, WP 0067 00)

Personnel Required

One

Materials/Parts

Alcohol, Isopropyl (Item 2, WP 0092 00)
Baled Rag, General (Item 3, WP 0092 00)
Compound, Sealer Pipe (Item 5, WP 0092 00)
Kit, Float Assembly Repair (Item 9, WP 0092 00)
Mat, Petroleum Absorbent (Item 11, WP 0092 00)
Wire Markers (Item 19, WP 0092 00)

Equipment Condition

Heater shut down, cool, and all advisory lights off (WP 0006 00).
In-tent controller assembly disconnected from heater (WP 0006 00).
Fuel supply disconnected. (WP 0006 00)
Sediment strainer emptied of fuel (WP 0035 00).
Battery disconnected (WP 0043 00).
Upper housing assembly removed (WP 0052 00).

SERVICE**Clean the Float Assembly****WARNING**

Be sure to disconnect battery connector before performing any maintenance procedures. Failure to do so may cause sparking or short circuits which might cause a fire or damage heater components.

**WARNING**

Fuels are toxic. Wear eye/face protection, impervious hand protection, avoid contact with skin and clothes, and don't breathe vapors. The use of protective gloves will significantly reduce the risks of exposure by prevent contact with skin. If contact with eyes or skin is made, immediately flush with clean water and get medical aid for eyes. If contact with clothing or skin is made, immediately remove contaminated clothing and clean skin with mild soap or cleanser and flush with clean water. Failure to observe these precautions could result in exposure to fuel, resulting in serious illness.

NOTE

Manage and dispose of fuel and fuel absorbent pads or wipes in accordance with appropriate state, local, and installation environmental regulations.

1. Place a petroleum absorbent mat under the fuel drain valve (**Figure 1, Item 1**).
2. Open drain valve (**Figure 1, Item 1**) onto mat to drain fuel from the float assembly (**Figure 1, Item 2**).
3. Disconnect the fuel hose (**Figure 1, Item 3**) and the vent line (**Figure 1, Item 4**).
4. Remove the four screws retaining the float bowl cover (**Figure 1, Item 5**), and gently lift the float bowl cover from the float assembly (**Figure 1, Item 2**).
5. Remove the gasket (**Figure 2, Item 1**) and set aside.

CAUTION

When the pivot pin is removed, the float, needle, and spring will detach from the cover and from each other. All three components are delicate and easily damaged or lost. Ensure that the float and needle can be caught and prevented from loss within the heater before removing the pivot pin.

6. Remove the float bowl pivot pin (**Figure 2, Item 2**), and then remove the float (**Figure 2, Item 3**) with float needle (**Figure 2, Item 4**) and spring (**Figure 2, Item 5**).
7. Remove the float needle (**Figure 2, Item 4**) and spring (**Figure 2, Item 5**) from the float (**Figure 2, Item 3**), and inspect the float for indications of damage, corrosion, or leakage.
8. Use a lint-free cloth and isopropyl alcohol to clean the tip of the float needle (**Figure 2, Item 4**), and the corresponding float needle seat in the float bowl cover (**Figure 2, Item 6**). Ensure no debris is left on either.
9. Install the float needle (**Figure 2, Item 4**) and spring (**Figure 2, Item 5**) onto the float (**Figure 2, Item 3**), and then install the assembled float, needle, and spring onto the float bowl cover (**Figure 2, Item 6**) and retain with the float bowl pivot pin (**Figure 2, Item 2**).
10. Ensure the float bowl gasket (**Figure 2, Item 1**) is clean and undamaged. Replace an unserviceable float bowl gasket.
11. Ensure the float bowl gasket (**Figure 2, Item 1**) is in place, and install the float bowl cover (**Figure 2, Item 6**) onto the float assembly (**Figure 2, Item 7**), and retain in place with four screws.
12. Unscrew the male elbow (**Figure 2, Item 8**) from the float bowl cover (**Figure 2, Item 6**), and remove the inlet screen inside the float bowl cover.
13. Use a lint-free cloth to clean the inlet screen, and reinstall the screen.
14. Apply a small amount of pipe sealing compound to the threads of the male elbow (**Figure 2, Item 8**), and install the elbow onto the float bowl cover (**Figure 2, Item 6**). Ensure the elbow is both tight and oriented correctly.
15. Reconnect the fuel hose (**Figure 1, Item 3**) and the vent line (**Figure 1, Item 4**).
16. Close the drain valve (**Figure 1, Item 1**).
17. Install the upper housing IAW WP 0052 00, and install the duct adapters IAW WP 0039 00.
18. Set up and operate the heater IAW WP 0005 00 and WP 0006 00, and monitor for normal operation.

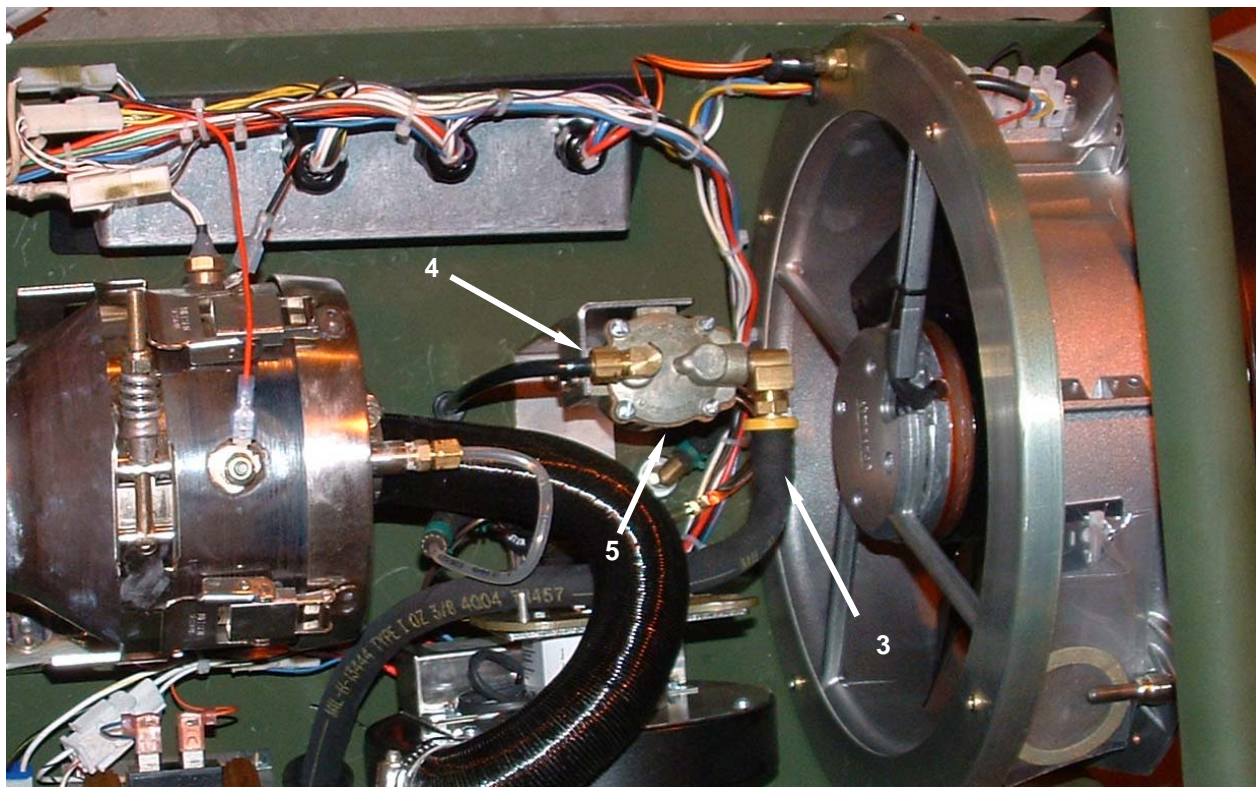
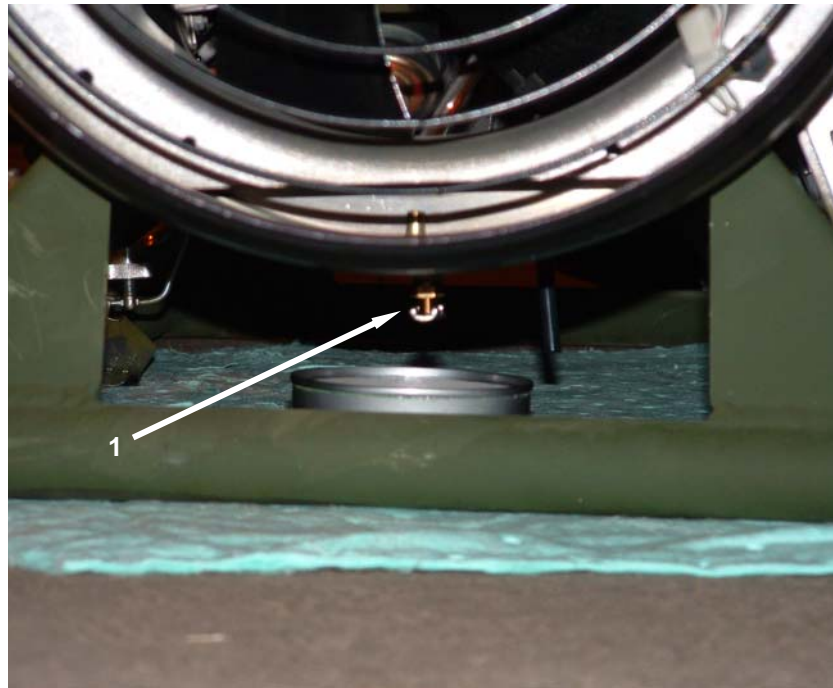

Figure 1. Clean the Float Assembly.

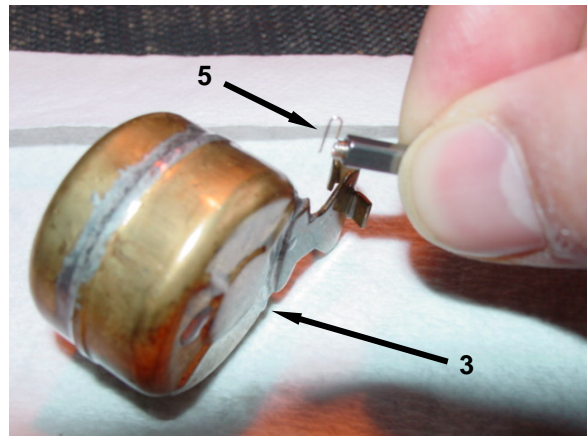
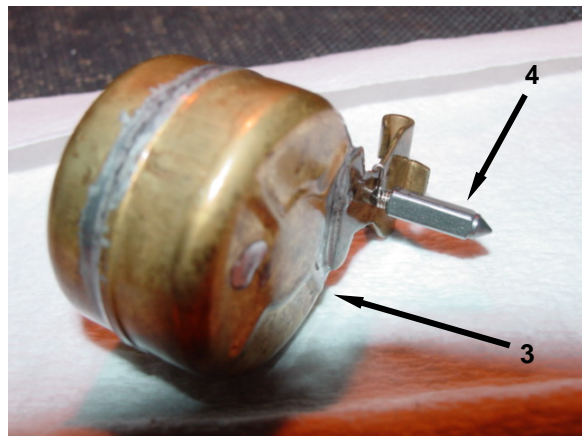
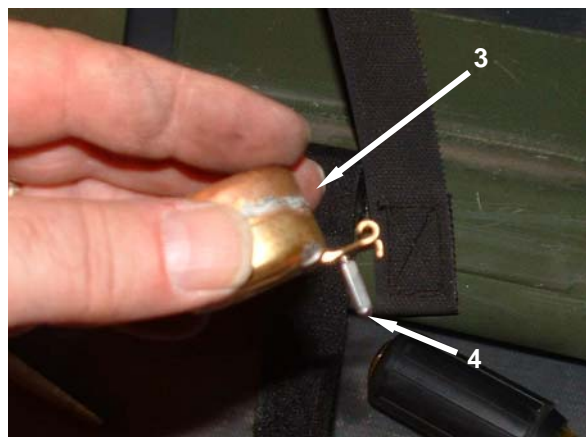
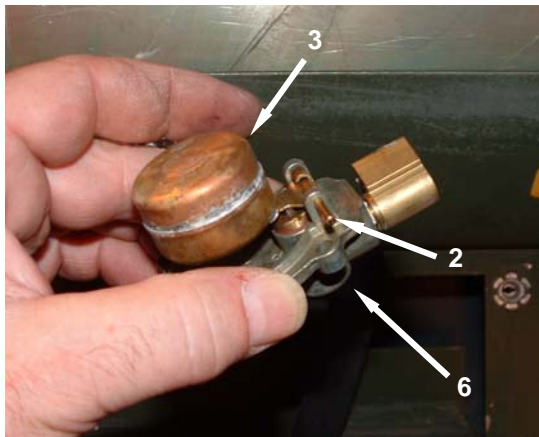
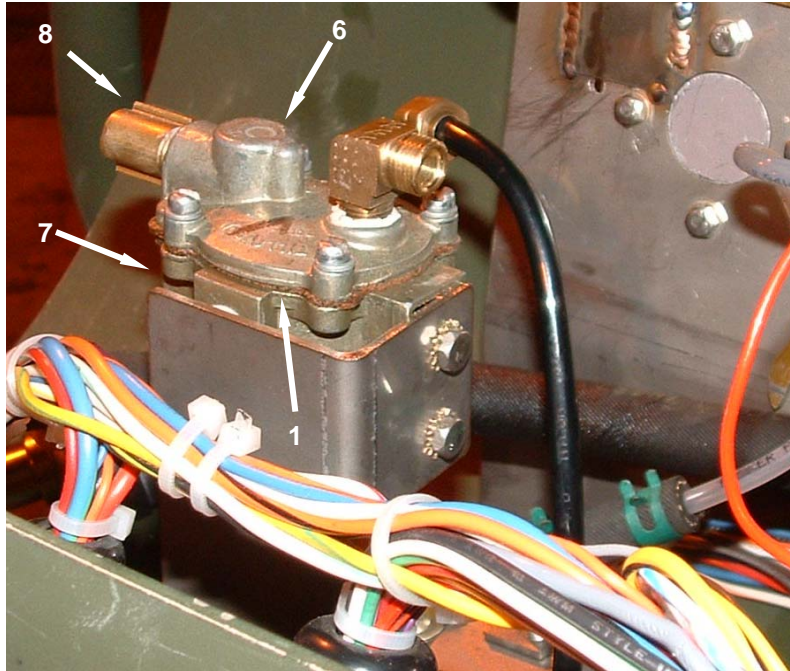

Figure 2. Clean the Float Assembly Needle Valve.

REPLACE**Replace the Float Assembly****WARNING**

Be sure to disconnect battery connector before performing any maintenance procedures. Failure to do so may cause sparking or short circuits which might cause a fire or damage heater components.

1. Place a petroleum absorbent mat under the fuel drain valve (**Figure 3, Item 1**).
2. Open drain valve (**Figure 3, Item 1**) to drain fuel into an approved container.
3. Remove the valve core from the drain valve (**Figure 3, Item 1**).
4. Remove the nut (**Figure 3, Item 2**) retaining the drain valve (**Figure 3, Item 1**), and pull the drain valve clear of the lower housing assembly.
5. Loosen and remove the fuel vent line fitting (**Figure 4, Item 1**) on the top assembly (**Figure 4, Item 2**) of the float assembly (**Figure 4, Item 3**).
6. Remove the fuel inlet hose (**Figure 4, Item 4**) from the float assembly inlet fitting (**Figure 4, Item 5**).
7. Release the hose clamp retaining the clear plastic fuel line (**Figure 4, Item 6**) connecting the float assembly (**Figure 4, Item 3**) to the fuel pump (**Figure 4, Item 7**), and remove the fuel line from the float assembly.
8. Loosen and remove the two screws (**Figure 4, Item 8**) that secure the float assembly (**Figure 4, Item 3**) to the float assembly bracket (**Figure 4, Item 9**).
9. Remove the float assembly (**Figure 4, Item 3**) from the heater and move it onto a petroleum absorbent mat or tray. Wipe up any spilled fuel.
10. Remove the valve core from the drain valve (**Figure 4, Item 10**) on the replacement float assembly.
11. Remove the nut (**Figure 4, Item 11**) from the drain valve (**Figure 4, Item 10**) on the replacement float assembly (**Figure 4, Item 3**).
12. Position the replacement float assembly (**Figure 4, Item 3**) on the bracket (**Figure 4, Item 9**) and secure with two screws (**Figure 4, Item 8**).
13. Install the drain valve (**Figure 4, Item 10**) into the lower housing assembly, and retain with nut (**Figure 4, Item 11**).
14. Install the valve core into the drain valve (**Figure 4, Item 10**), and tighten.
15. Connect the clear plastic fuel line (**Figure 4, Item 6**) coming from the fuel pump (**Figure 4, Item 7**) to the float assembly (**Figure 4, Item 3**), and ensure the hose clamp is in place.
16. Install the fuel inlet hose (**Figure 4, Item 4**) on the float assembly inlet fitting (**Figure 4, Item 5**).

17. Install and tighten the fuel vent line (**Figure 4, Item 1**) on top assembly (**Figure 4, Item 2**), and ensure the vent line is fitted into the grommet in the lower housing assembly.
18. Close drain valve (**Figure 4, Item 10**).
19. Install the upper housing IAW WP 0052 00, and install the duct adapters IAW WP 0039 00.
20. Set up and operate the heater IAW WP 0005 00 and WP 0006 00, and monitor for normal operation.

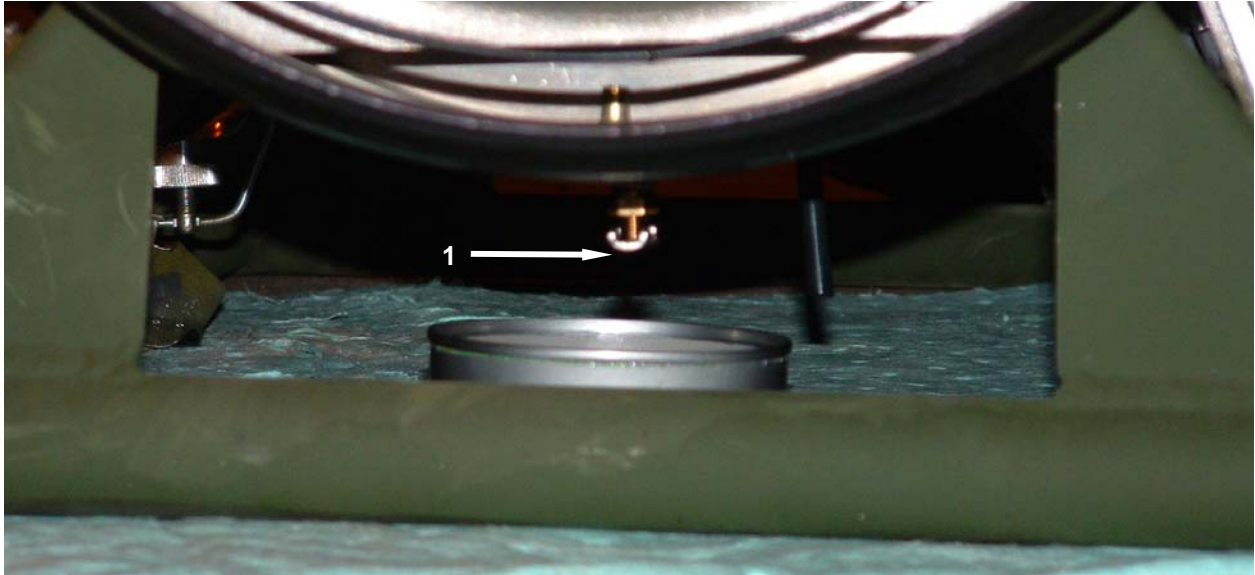

Figure 3. Replace the Float Assembly – Fuel Drain.

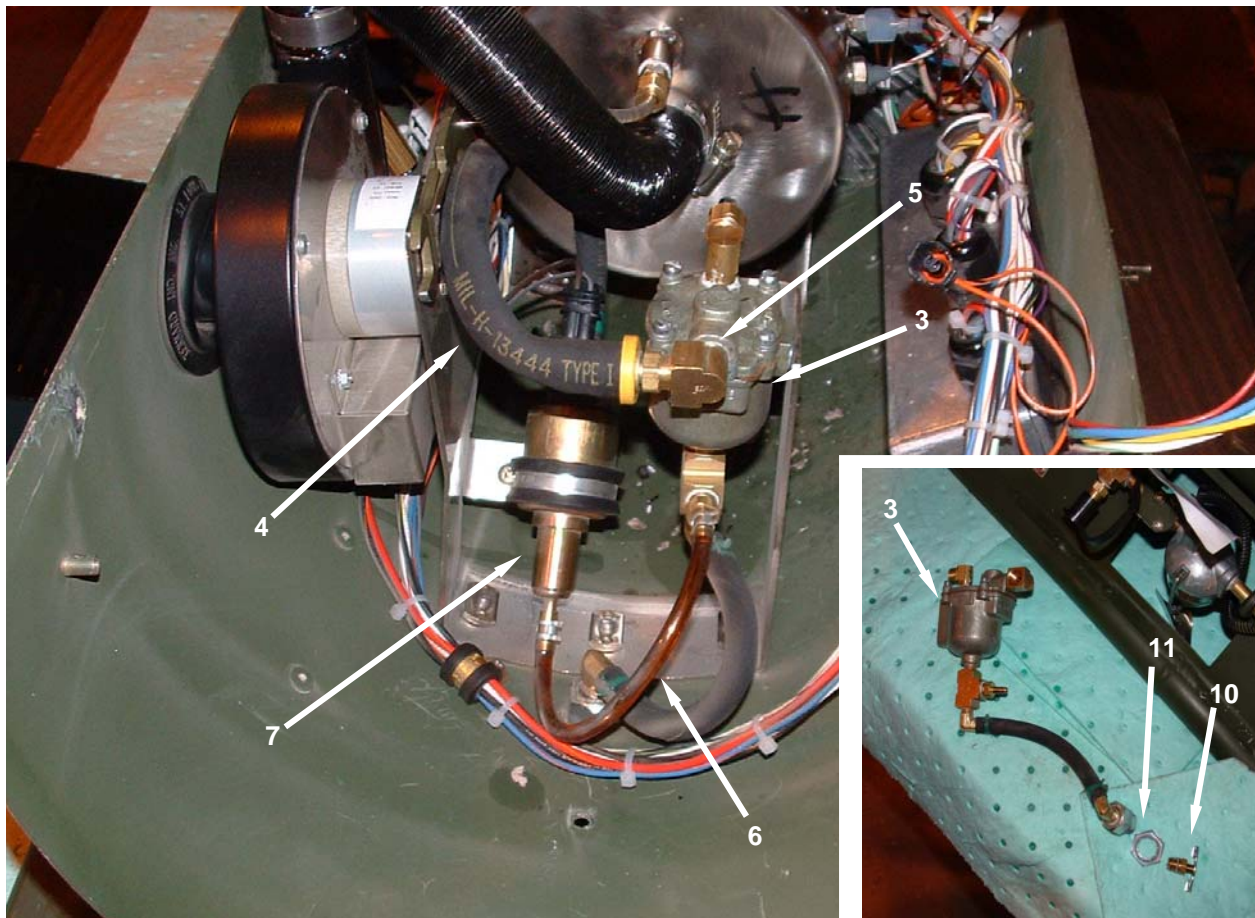
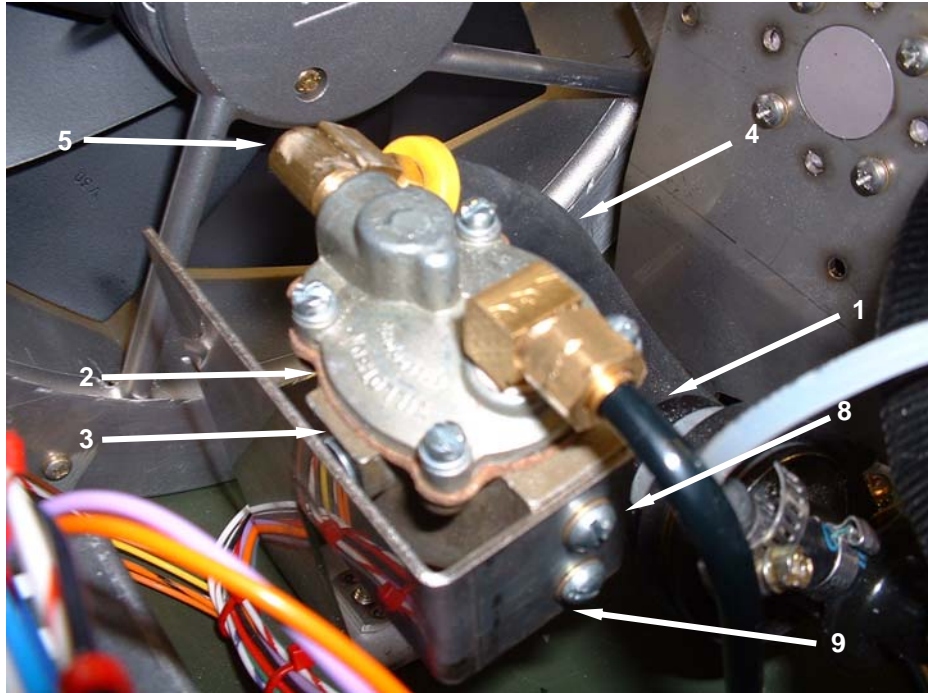

Figure 4. Replace the Float Assembly.

END OF WORK PACKAGE

**UNIT MAINTENANCE
SPACE HEATER, CONVECTIVE 60K BTU (SHC-60K)
NSN 4520-01-520-6477
BURNER ASSEMBLY
REMOVE, INSPECT, REPLACE, INSTALL**

INITIAL SETUP:**Tools**

Tool Kit, General Mechanic's (Item 1, WP 0067 00)

Personnel Required

Two

Materials/Parts

Baled Rag, General (Item 3, WP 0092 00)
Gasket (Item 6, WP 0092 00)
Kit, Burner (Item 8, WP 0092 00)
Mat, Petroleum Absorbent
(Item 11, WP 0092 00)
Screen (Item 12, WP 0092 00)

Equipment Condition

Heater shut down, cool, and all advisory lights off (WP 0006 00).
In-tent controller assembly disconnected from heater (WP 0006 00).
Fuel supply disconnected (WP 0006 00).
Sediment strainer emptied of fuel (WP 0035 00).
Battery disconnected (WP 0043 00).
Upper housing assembly removed (WP 0052 00).

REMOVE**Remove the Burner Assembly****WARNING**

Be sure to disconnect battery connector before performing any maintenance procedures. Failure to do so may cause sparking or short circuits which might cause a fire or damage heater components.

**WARNING**

Fuels are toxic. Wear eye/face protection, impervious hand protection, avoid contact with skin and clothes, and don't breathe vapors. The use of protective gloves will significantly reduce the risks of exposure by prevent contact with skin. If contact with eyes or skin is made, immediately flush with clean water and get medical aid for eyes. If contact with clothing or skin is made, immediately remove contaminated clothing and clean skin with mild soap or cleanser and flush with clean water. Failure to observe these precautions could result in exposure to fuel, resulting in serious illness.

NOTE

Manage and dispose of fuel and fuel absorbent pads or wipes in accordance with appropriate state, local, and installation environmental regulations.

1. Place a petroleum absorbent mat under the burner assembly to catch any fuel that may spill.
2. Disconnect fuel line (**Figure 1, Item 1**) at fitting (**Figure 1, Item 2**). Carefully collect fuel which may spill from the hose. Wipe up any spilled fuel.
3. Disconnect combustion air inlet duct (**Figure 1, Item 3**) by loosening hose clamp (**Figure 1, Item 4**) and sliding the clamp up the duct. Pull the combustion air inlet duct off the burner assembly air inlet and move off to the side.
4. Tag and disconnect wires from flame sensor (**Figure 1, Item 5**) and glow plug (**Figure 1, Item 6**).
5. Tag and disconnect the ground wire (**Figure 1, Item 7**).
6. Loosen the TEG clamp (**Figure 1, Item 8**), and slide the clamp free of the TEG (**Figure 1, Item 9**).
7. Loosen the mounting clamp (**Figure 1, Item 10**), and slide the clamp free of its mounting bracket.
8. Remove burner (**Figure 2, Item 1**).
9. Remove burner mantle (**Figure 2, Item 2**).
10. Clean graphite tape residue from the outer rim of the burner (**Figure 2, Item 1**) and the TEG (**Figure 2, Item 3**).
11. Clean all graphite tape residue from the TEG clamp (**Figure 2, Item 4**).

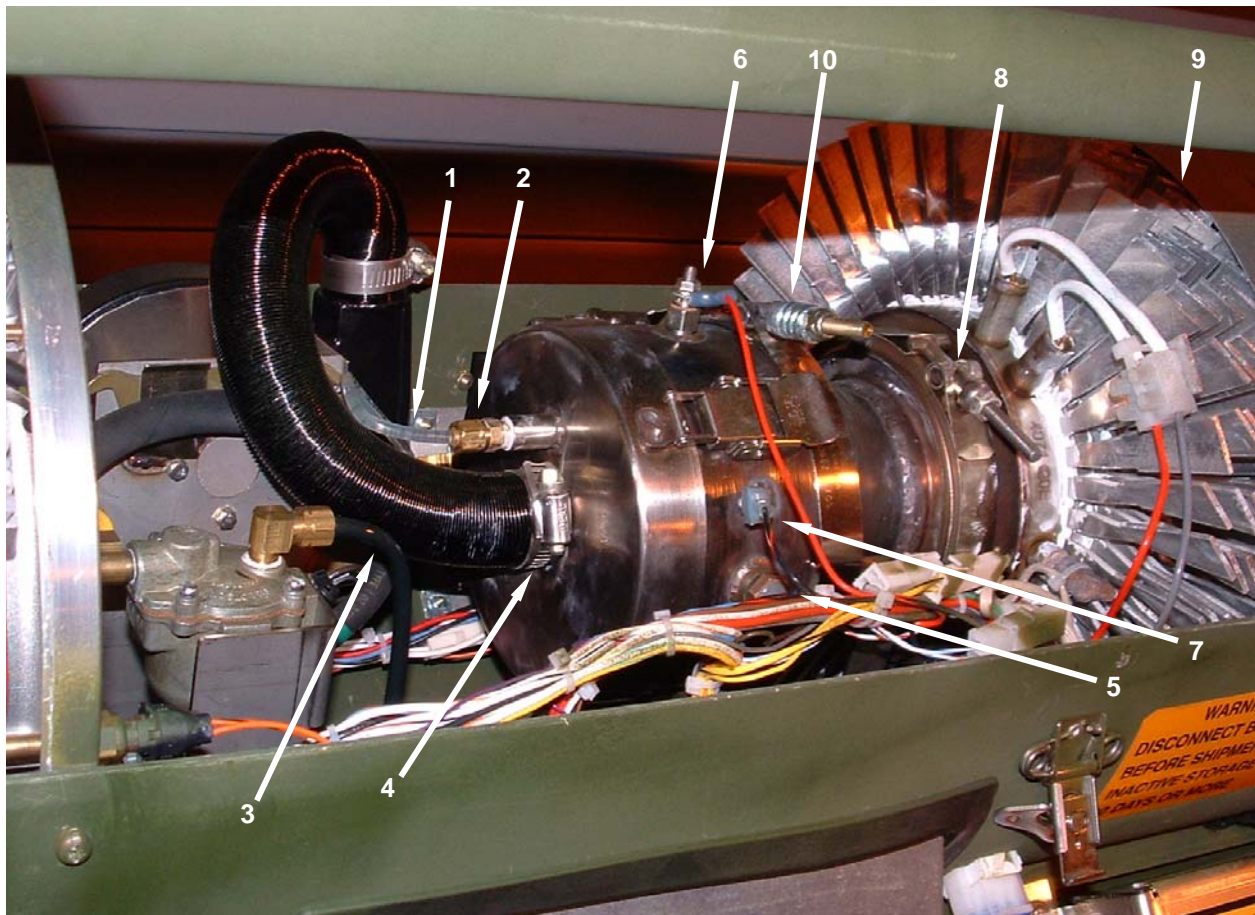

Figure 1. Remove Burner Assembly.

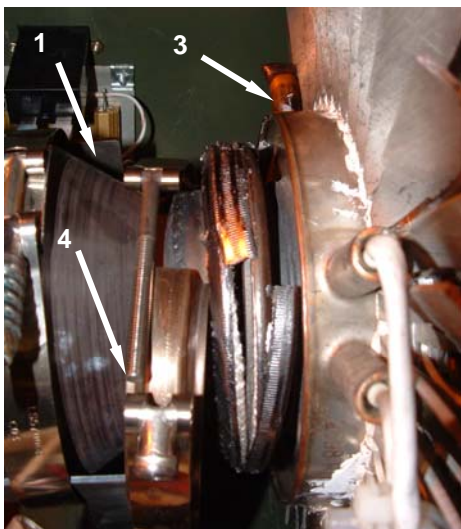
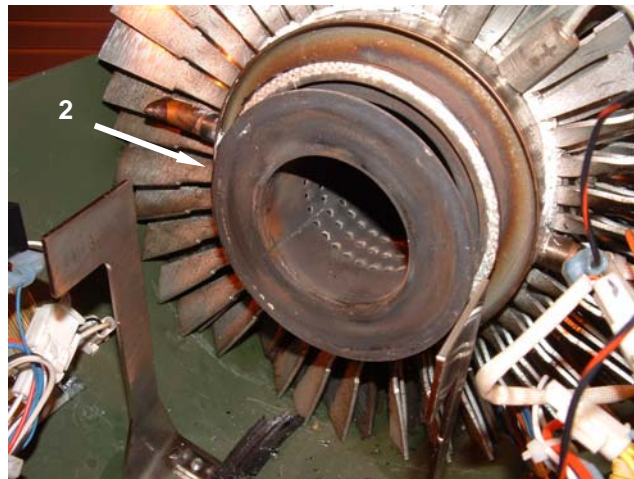
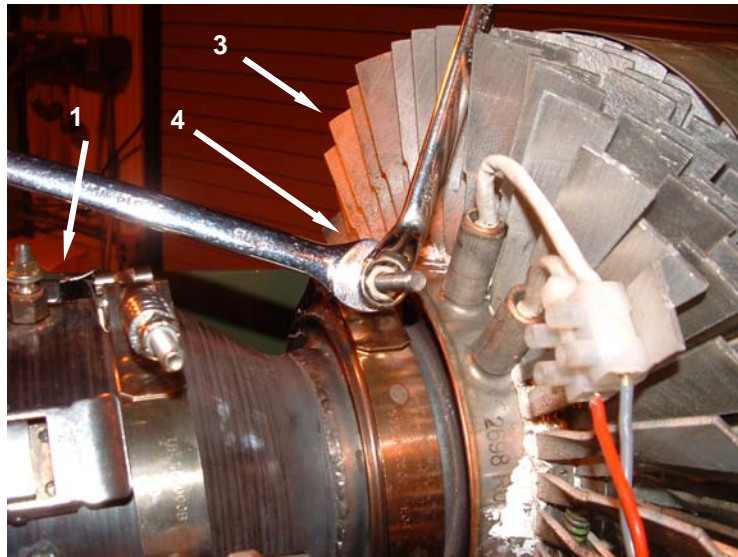

Figure 2. Burner Assembly Removal.

INSPECT**Inspect the Burner Assembly**

1. Remove the burner assembly as detailed in REMOVE.
2. Inspect the burner assembly components for any bends, dents, or other damage that would prevent the components from fitting together properly.
3. Inspect the mantle assembly (**Figure 3, Item 1**) to ensure that it does not have damage, excessive wear, or burned-through holes. If the mantle does have damage, excessive wear, or burned-through holes, replace the burner assembly as detailed later in this work package.
4. Inspect the mantle assembly (**Figure 3, Item 1**) and ensure that it does not have a carbon buildup. If so, clean the mantle assembly with a wire brush and lint-free wiping cloth.
5. Inspect the burner interior (**Figure 3, Item 2**) for excessive carbon deposits, presence of liquid fuel, and material damage to the burner cavity. Clean the burner assembly IAW WP 0036 00. Replace a damaged burner assembly.
6. Inspect the burner wick (**Figure 3, Item 3**) IAW 0036 00.

CAUTION

Use care when clearing the fuel inlet of soot and debris. Metal tools such as scribes should be used very carefully to prevent damage to the inside of the fitting. Use of compressed air, if available, is preferred.

7. Inspect the fuel inlet (**Figure 3, Item 4**) to the burner for clogging debris, and remove as needed. Compressed air or any field expedient method may be used which will not damage the interior of the fuel inlet fitting.
8. After inspection, reassemble burner assembly components and install burner assembly as detailed in INSTALL.



Figure 3. Inspect Burner Assembly.

REPLACE**Replace the Burner Assembly**

1. Remove the burner assembly (**Figure 4, Item 1**) as instructed in the REMOVE section of this WP.
2. Remove the glow plug (**Figure 4, Item 2**) and the flame sensor (**Figure 4, Item 3**) from the burner assembly (**Figure 4, Item 1**), and retain for reuse.
3. Install the replacement burner assembly (**Figure 4, Item 1**) as instructed in the INSTALL section of this WP.

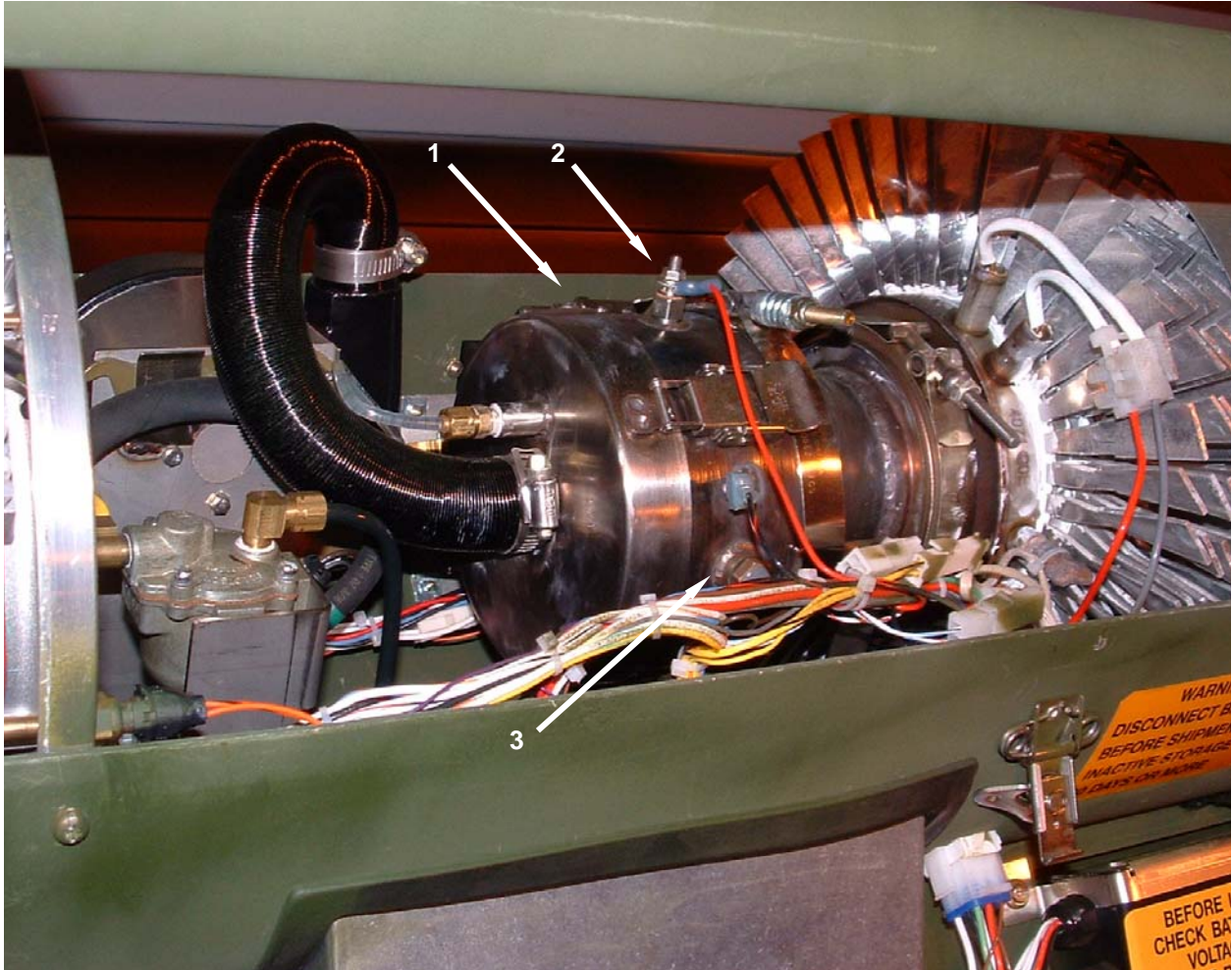

Figure 4. Replace the Burner Assembly.

INSTALL

Install the Burner Assembly

1. Ensure that the mantle (**Figure 5, Item 1**) is in place inside the TEG (**Figure 5, Item 2**).
2. Ensure that the fiberglass rope (**Figure 5, Item 3**) is in place in the groove on the front surface of the TEG flange (**Figure 5, Item 4**).
3. Move the burner assembly (**Figure 5, Item 5**) toward the mantle (**Figure 5, Item 1**) and TEG (**Figure 5, Item 2**) and seat it against the TEG flange (**Figure 5, Item 4**). Ensure that the glow plug is located in the vertical (12 o'clock) position.



WARNING

Failure to properly install graphite ribbon seal may cause combustion gases to leak into inlet air stream leading to carbon monoxide poisoning and death.

CAUTION

The burner must be correctly aligned (with the glow plug in the vertical position) before applying the graphite ribbon seal. Attempting to adjust the alignment after the ribbon seal has been applied will damage the graphite seal material, causing a potentially fatal carbon monoxide leak.

4. Install new graphite ribbon seal (**Figure 5, Item 6**) around the circumference of the TEG flange (**Figure 5, Item 4**) and the burner flange (**Figure 5, Item 7**). Center the graphite ribbon tape so that it equally overlaps both flanges. Overlap the ends of the graphite ribbon tape by approximately 1 to 1 1/2 inches. Roll ribbon seal over edges of both flanges to ensure a good seal.
5. Install and secure the burner assembly (**Figure 5, Item 5**) to the TEG (**Figure 5, Item 2**) with the V-clamp (**Figure 5, Item 8**). Do not rotate the clamp once it is over the graphite ribbon seal (**Figure 5, Item 6**). Tighten the two nuts securely.
6. Secure the new burner assembly (**Figure 5, Item 5**) onto the burner bracket (**Figure 5, Item 9**) with mounting clamp (**Figure 5, Item 10**). Ensure that the glow plug (**Figure 5, Item 11**) is positioned at the top.
7. Connect fuel line (**Figure 5, Item 12**) to burner assembly (**Figure 5, Item 5**) at fitting (**Figure 5, Item 13**).
8. Connect combustion air inlet pipe (**Figure 5, Item 14**) to burner assembly (**Figure 5, Item 5**) and secure with hose clamp (**Figure 5, Item 15**). Tighten clamp securely.
9. Connect the flame sensor connector (**Figure 5, Item 16**) and connect the wire to the glow plug (**Figure 5, Item 11**).
10. Reconnect ground wire (**Figure 5, Item 17**).
11. Install the upper housing IAW WP 0052 00, and install the duct adapters IAW WP 0039 00.
12. Set up and operate the heater IAW WP 0005 00 and WP 0006 00, and monitor for normal operation.

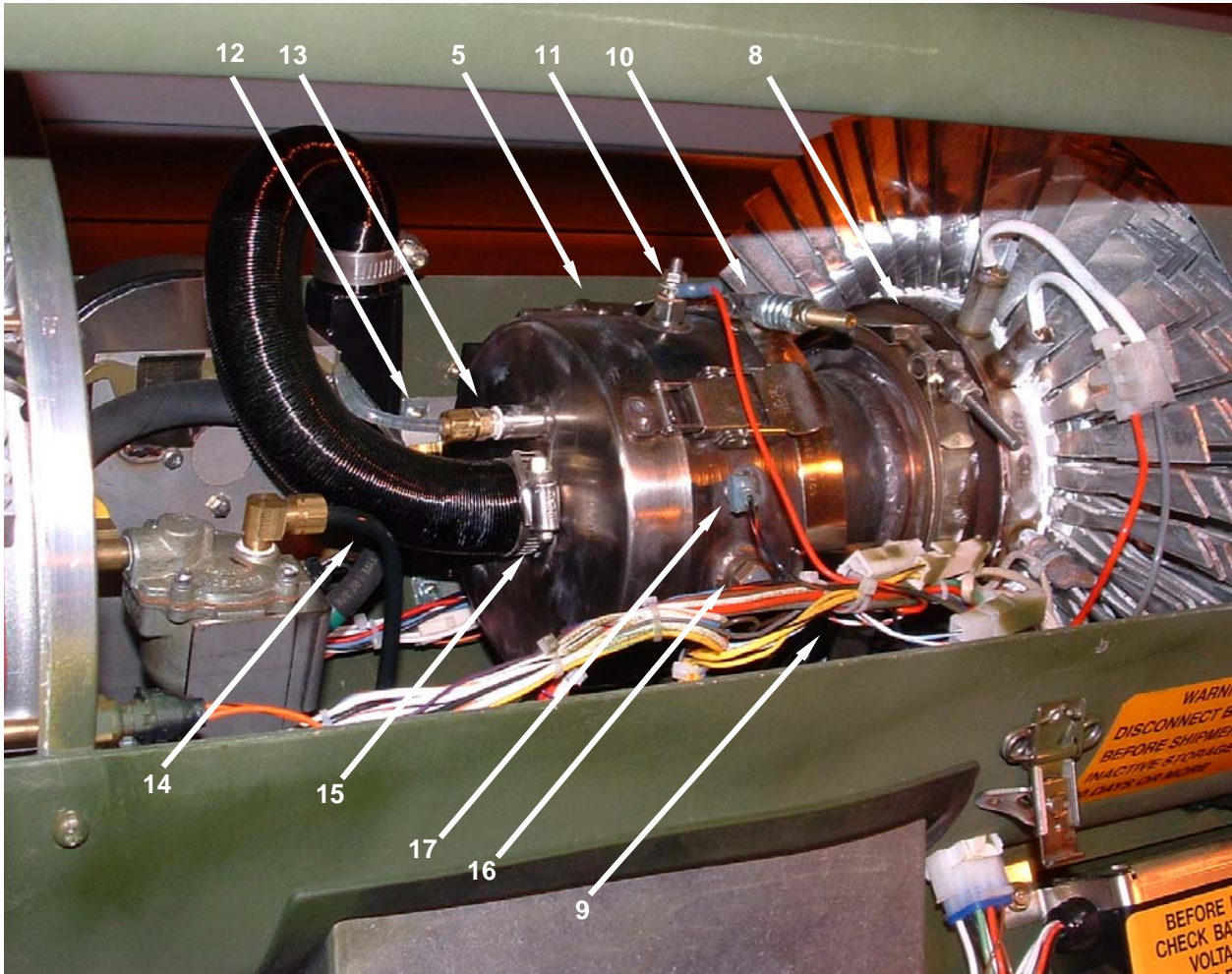
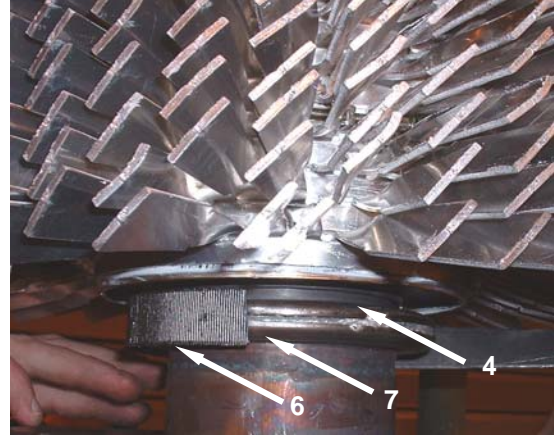
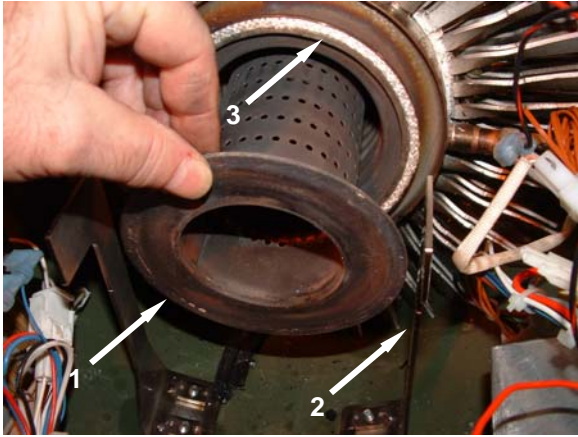

Figure 5. Install the Burner Assembly.

END OF WORK PACKAGE

UNIT MAINTENANCE
SPACE HEATER, CONVECTIVE 60K BTU (SHC-60K)
NSN 4520-01-520-6477
THERMOELECTRIC GENERATOR (TEG)
REMOVE, INSPECT, TEST, REPLACE, INSTALL

INITIAL SETUP:**Tools**

Tool Kit, General Mechanic's (Item 1, WP 0067 00)

Personnel Required

Two

Materials/Parts

Baled Rag, General (Item 3, WP 0092 00)
 Mat, Petroleum Absorbent (Item 11, WP 0092 00)
 Seal, Graphite Ribbon (Item 13, WP 0092 00)
 Wire Markers (Item 19, WP 0092 00)

Equipment Condition

Heater shut down and all advisory lights off (WP 0006 00).
 In-tent controller assembly disconnected from heater (WP 0006 00).
 Fuel supply disconnected (WP 0006 00).
 Battery disconnected (WP 0043 00).
 Upper housing assembly removed (WP 0052 00).

REMOVE**Remove the Thermoelectric Generator (TEG)**

WARNING

Be sure to disconnect battery connector before performing any maintenance procedures. Failure to do so may cause sparking or short circuits which might cause a fire or damage heater components.

NOTE

The burner assembly may be removed in place IAW WP 0060 00 if desired.

NOTE

Manage and dispose of fuel and fuel absorbent pads or wipes in accordance with appropriate state, local, and installation environmental regulations.

1. Place a section of petroleum absorbent mat in the bottom of the lower housing assembly under the burner assembly in order to catch any fuel that may spill. Wipe up any spilled fuel with a rag.
2. Remove manual thermostat reset switch as described in WP 0057 00 and set aside.
3. Tag and disconnect the glow plug wire (**Figure 1, Item 1**), flame sensor connector (**Figure 1, Item 2**), ground wire (**Figure 1, Item 3**), fuel line (**Figure 1, Item 4**), and combustion air blower hose (**Figure 1, Item 5**) from the burner assembly (**Figure 1, Item 6**).
4. Tag and disconnect the two TEG electrical connectors (**Figure 1, Items 7**).

5. Tag and disconnect the two wires (**Figure 2, Item 1**) going into the modular connector (**Figure 2, Item 2**) on the side of the TEG by loosening the two bottom screws. Do not loosen the top screws for the wires that enter the interior of the TEG.
6. Loosen the clamp (**Figure 1, Item 10**) retaining the burner assembly (**Figure 1, Item 6**) and lift assembled burner, heat exchanger (**Figure 2, Item 3**) and TEG (**Figure 2, Item 4**) and remove from heater. Place on an appropriate work surface. Take care not to bend any of the fins on the TEG.
7. Remove the exhaust grommet (**Figure 2, Item 5**) by stretching the grommet over the ridge and sliding down and off the combustion exhaust outlet. Set the grommet aside.
8. Stand the assembled burner, heat exchanger, and TEG on end, and remove sheet metal screws (**Figure 2, Item 6**) and washers (**Figure 2, Item 7**) from wrap cover (**Figure 2, Item 8**) and set aside.
9. Carefully remove the wrap cover (**Figure 2, Item 8**) and set aside.
10. Loosen and remove flange clamp (**Figure 2, Item 9**) between the heat exchanger (**Figure 2, Item 3**) and the TEG (**Figure 2, Item 4**).
11. Separate TEG (**Figure 2, Item 4**) and heat exchanger (**Figure 2, Item 3**).
12. Loosen and remove the flange clamp between the burner assembly and the TEG. Separate the burner assembly from the TEG.
13. Remove and discard all pieces of old graphite ribbon tape that may adhere to the inside surface of both flange clamps (**Figure 2, Item 9**) and to the outside of the TEG, heat exchanger, and burner assembly flanges.

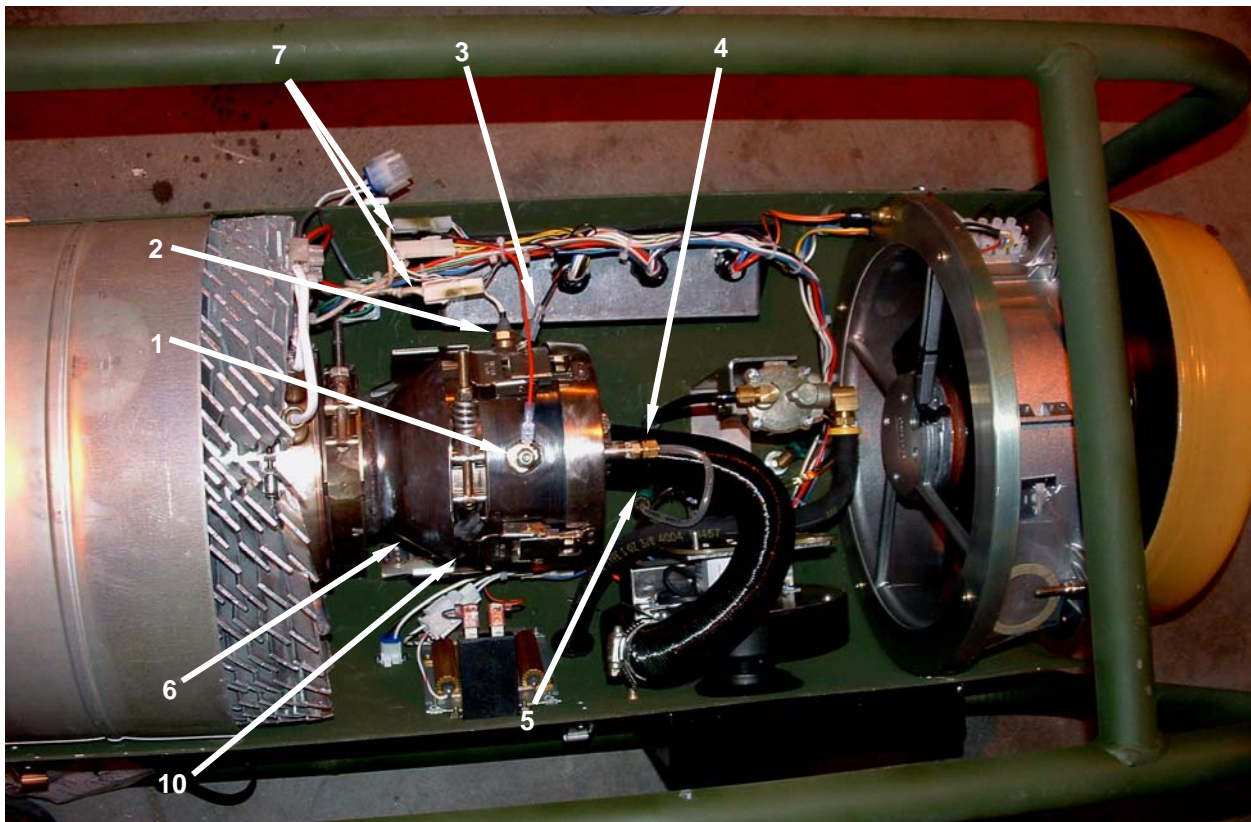

Figure 1. Remove Thermoelectric Generator (TEG).

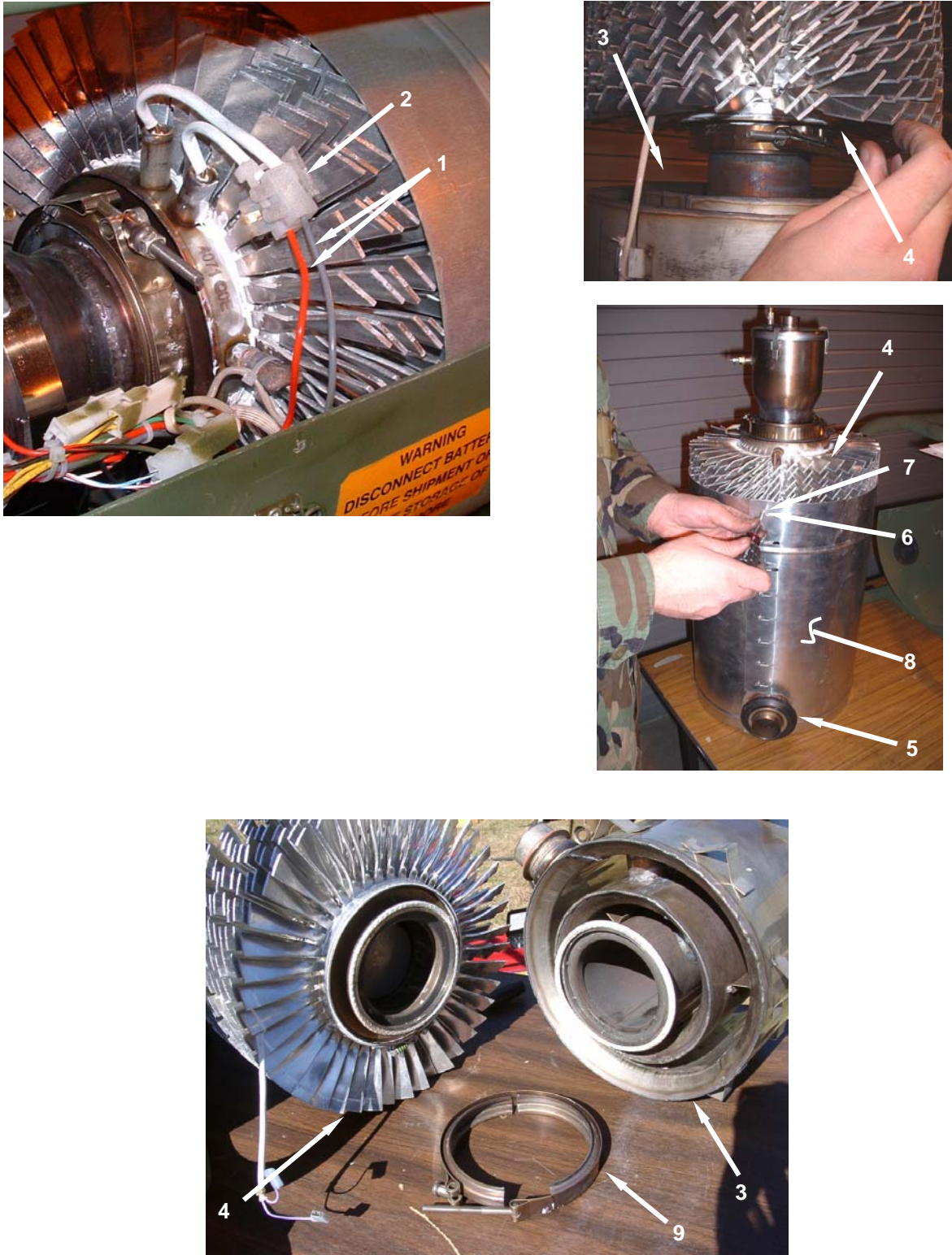

Figure 2. Thermoelectric Generator (TEG) Removal.

INSPECT**Inspect Thermoelectric Generator (TEG)**

1. Check flanges (**Figure 3, Item 1**) for bends, breaks, and corrosion.
2. Inspect flange clamp (**Figure 3, Item 2**) for distortion as well as stripped and otherwise damaged threads. Discard clamp if not fully functional.
3. Ensure that the fiberglass ropes (**Figure 3, Item 3**) are positioned in the grooves of the TEG flange and that they are not frayed or damaged in any way.

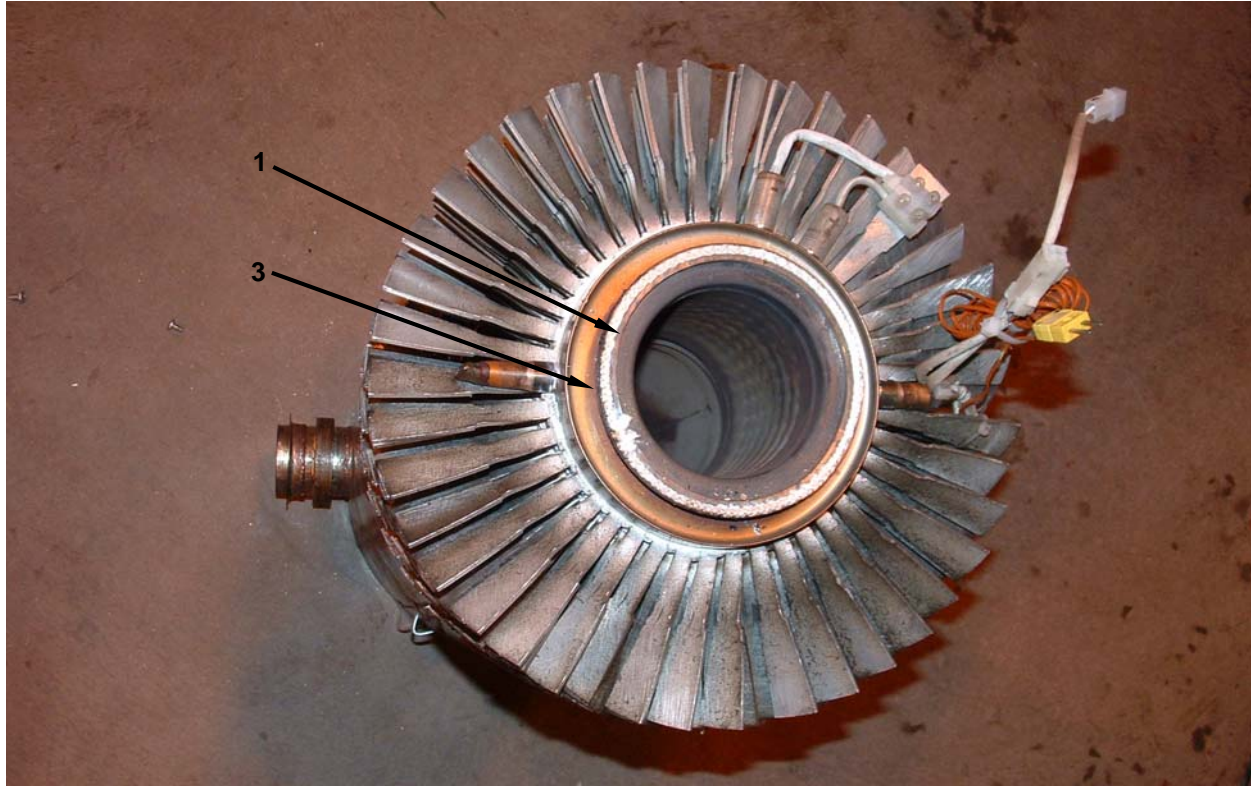

Figure 3. Inspect Thermoelectric Generator (TEG).

TEST**Test Thermoelectric Generator (TEG)**

1. If necessary, set the multimeter to measure resistance in the 10 ohm range.
2. Place probe No. 1 in contact with TEG's grey wire (**Figure 4, Item 1**) and probe No.2 in contact with the TEG's red wire (**Figure 4, Item 2**). The meter should read between 1 and 5 Ohms. It should not read 0 (zero) Ohms (shorted) or infinite Ohms (open).
3. Replace TEG if short or open is indicated.

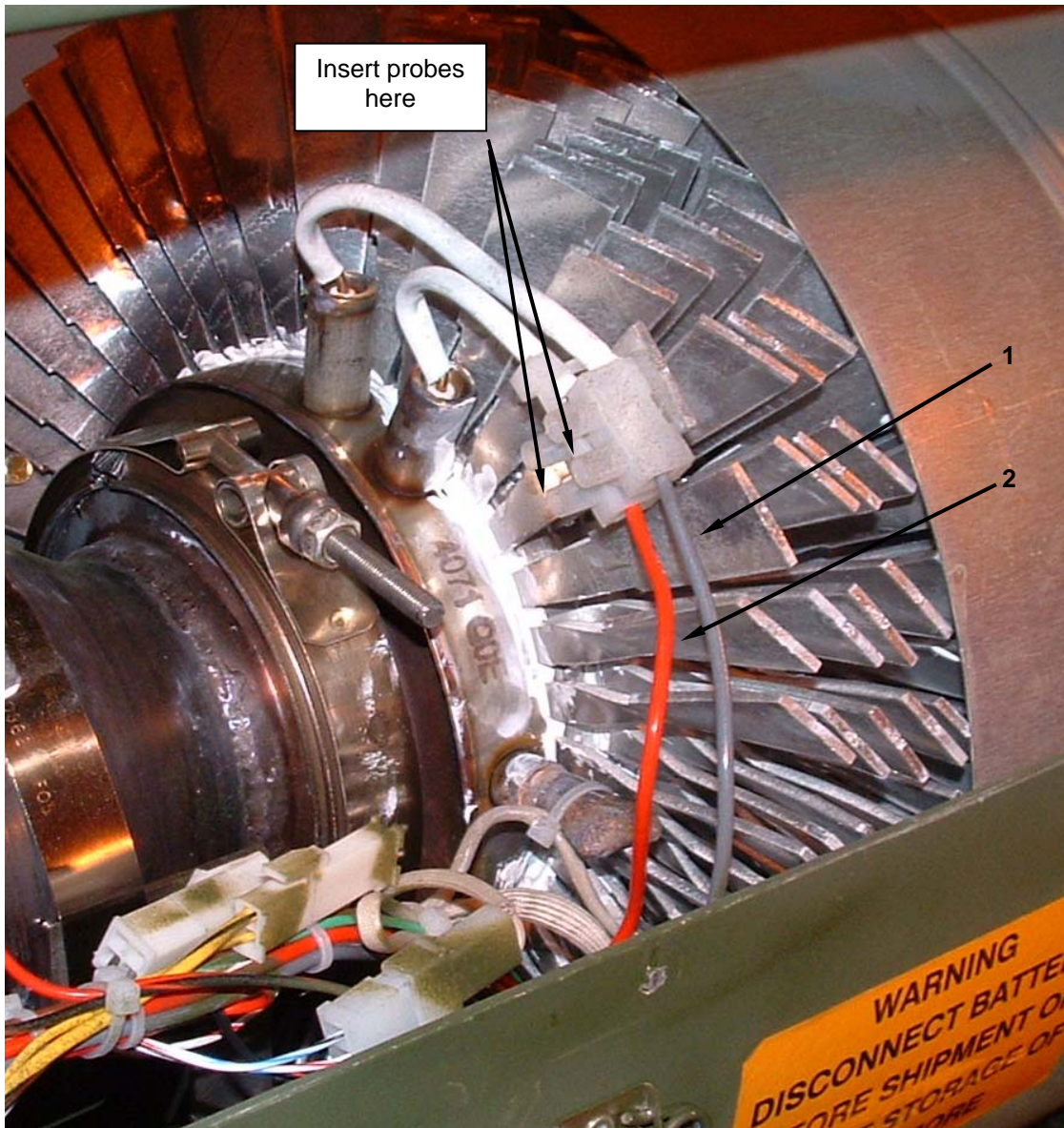

Figure 4. Test Thermoelectric Generator (TEG).

REPLACE**Replace Fin Temperature Sensor****WARNING**

Be sure to disconnect battery connector before performing any maintenance procedures. Failure to do so may cause sparking or short circuits which might cause a fire or damage heater components.

NOTE

Manage and dispose of fuel and fuel absorbent pads or wipes in accordance with appropriate state, local, and installation environmental regulations.

1. Place a section of petroleum absorbent mat in the bottom of the lower housing assembly under the burner assembly in order to catch any fuel that may spill. Wipe up any spilled fuel with a rag.
2. Remove manual thermostat reset switch as described in WP 0037 00 and set aside.
3. Tag and disconnect the glow plug (**Figure 5, Item 1**), flame sensor (**Figure 5, Item 2**), ground wire (**Figure 5, Item 3**), fuel line (**Figure 5, Item 4**), and combustion air blower duct (**Figure 5, Item 5**) from the burner assembly (**Figure 5, Item 6**).
4. Tag and disconnect the two TEG electrical connectors (**Figure 5, Items 7**).
5. Tag and disconnect the two wires (**Figure 5, Item 8**) going into the modular connector (**Figure 5, Item 9**) on the side of the TEG by loosening the two bottom screws. Do not loosen the top screws for the wires that enter the interior of the TEG.
6. Loosen the clamp (**Figure 5, Item 10**) retaining the burner assembly (**Figure 5, Item 6**) and lift the assembled burner, heat exchanger and TEG from the heater. Place on an appropriate work surface. Take care not to bend any of the fins on the TEG.

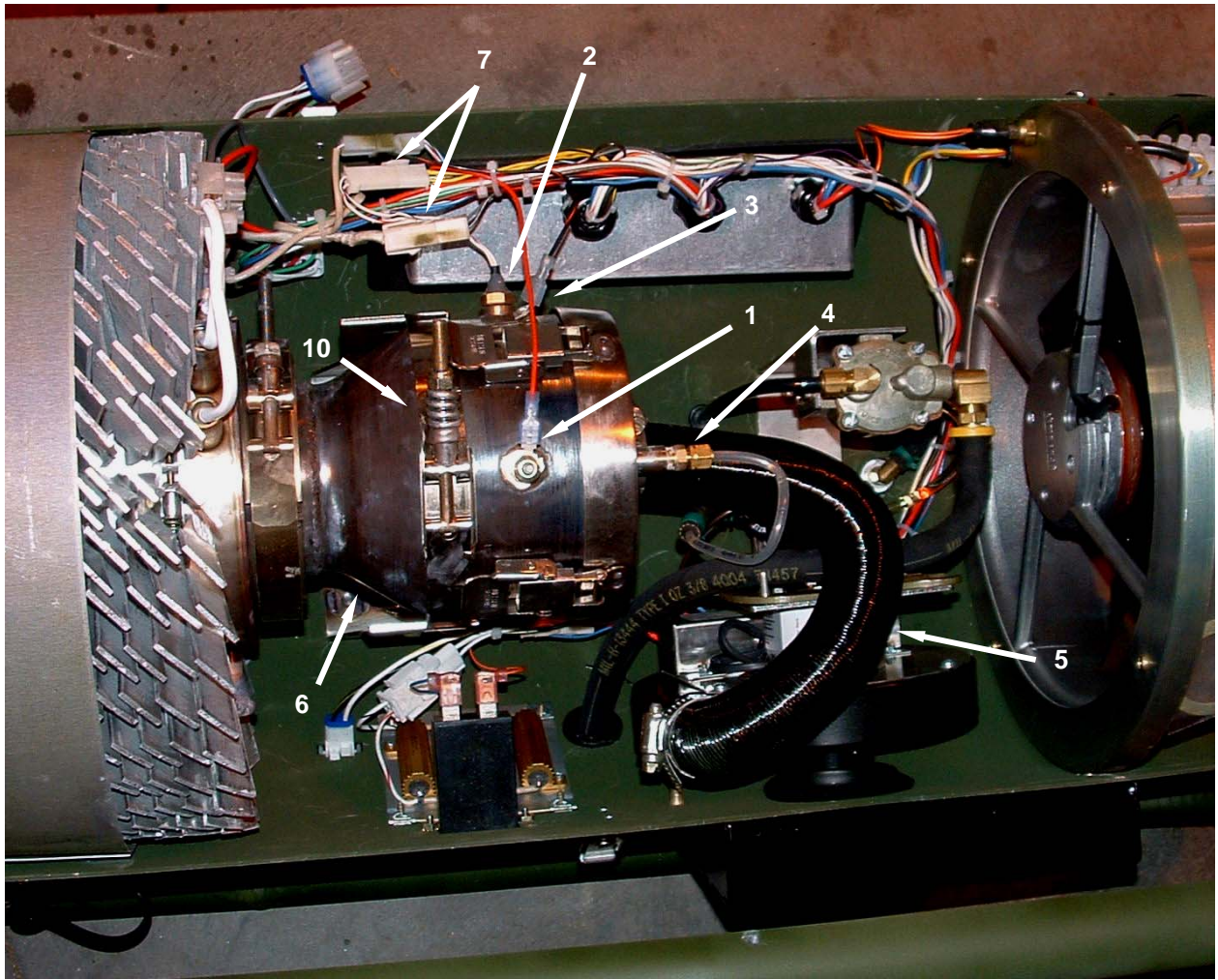

Figure 5. Replace Fin Temperature Sensor – Disassembly.

7. Stand the assembled burner (**Figure 6, Item 1**), heat exchanger (**Figure 6, Item 2**), and TEG (**Figure 6, Item 3**) on end, and remove sheet metal screws (**Figure 6, Item 4**) and washers from wrap cover (**Figure 6, Item 5**) and set aside.
8. Remove the exhaust grommet (**Figure 6, Item 6**) by stretching the grommet over the ridge and sliding down and off the combustion exhaust outlet. Set the grommet aside.
9. Carefully remove the wrap cover (**Figure 6, Item 5**) and set aside.



Figure 6. Replace Fin Temperature Sensor – Remove Wrap Cover.

10. Loosen the clamping screw (**Figure 7, Item 1**) retaining the lowest fin ring (**Figure 7, Item 2**), and gently remove the fin ring from the TEG.
11. Locate the holed fin (**Figure 7, Item 3**) adjacent to the fin temperature sensor (**Figure 7, Item 4**).
12. Place the replacement fin temperature sensor (**Figure 7, Item 4**) on the fin (**Figure 7, Item 3**), and retain in place with a rivet.
13. Cut the modular connector from the existing fin temperature sensor (**Figure 7, Item 4**).

CAUTION

Do not over tighten tie wraps. The edge of the fin may cut or crush the wire and the insulation. Failure to comply may result in damage to the equipment.

14. Route the fin temperature sensor wire (**Figure 7, Item 5**) alongside the existing wire, and retain in place with tie wraps. Trim the excess from the tie wraps after tightening.

CAUTION

The edge of the fin may cut or crush the wire and the insulation. Failure to comply may result in damage to the equipment.

15. Install the fin ring (**Figure 7, Item 2**) onto the TEG, making sure that the clamp screw (**Figure 7, Item 1**) is staggered from that on the next ring.
16. Tighten the clamp screw (**Figure 7, Item 1**) to retain the fin ring (**Figure 7, Item 2**) in place by bottoming the clamp screw, then backing it out two turns.

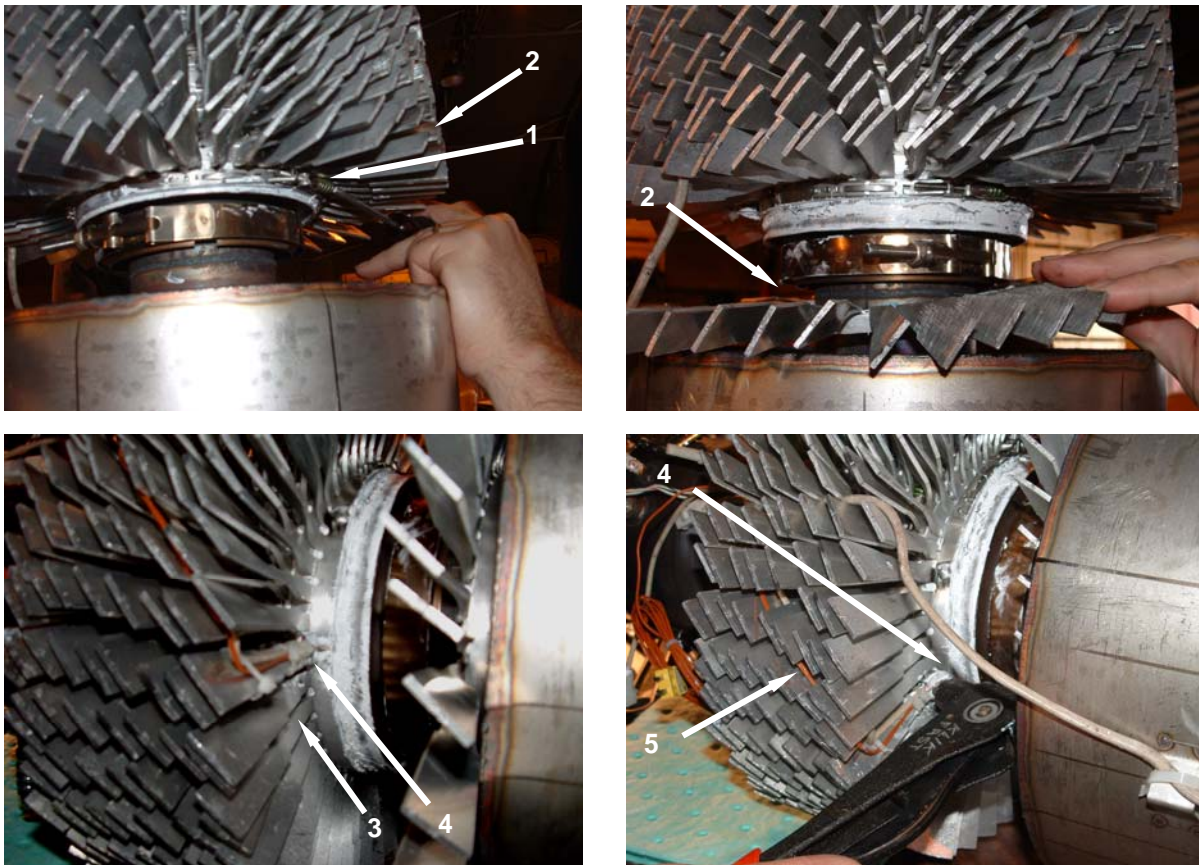

Figure 7. Replace Fin Temperature Sensor – Install Replacement Sensor.

17. Align cutouts in wrap cover (**Figure 8, Item 1**) with the combustion exhaust outlet (**Figure 8, Item 2**) and position around the heat exchanger (**Figure 8, Item 3**). Ensure that the wrap cover is positioned so that the thermostat reset switch, when installed, can be installed through the hole in the wrap cover and mounted to the bracket in the lower housing assembly. Also, ensure that the two wires and connectors tied to outside of the heat exchanger hang out of the hole in the wrap cover.
18. While holding the wrap cover (**Figure 8, Item 1**) securely in position, install sheet metal screws (**Figure 8, Item 4**) and washers. Tighten all screws securely.
19. Install exhaust grommet (**Figure 8, Item 5**) over combustion exhaust outlet (**Figure 8, Item 2**).



Figure 8. Replace Fin Temperature Sensor – Install Wrap Cover.

20. Place assembled heat exchanger, TEG, and burner assembly into heater and align combustion exhaust outlet (**Figure 9, Item 1**) and exhaust grommet (**Figure 9, Item 2**) with exhaust cutout in lower housing. Be sure to engage the groove in the grommet with the cutout in the lower housing assembly.
21. Tighten clamp (**Figure 9, Item 3**) retaining burner assembly (**Figure 9, Item 4**).

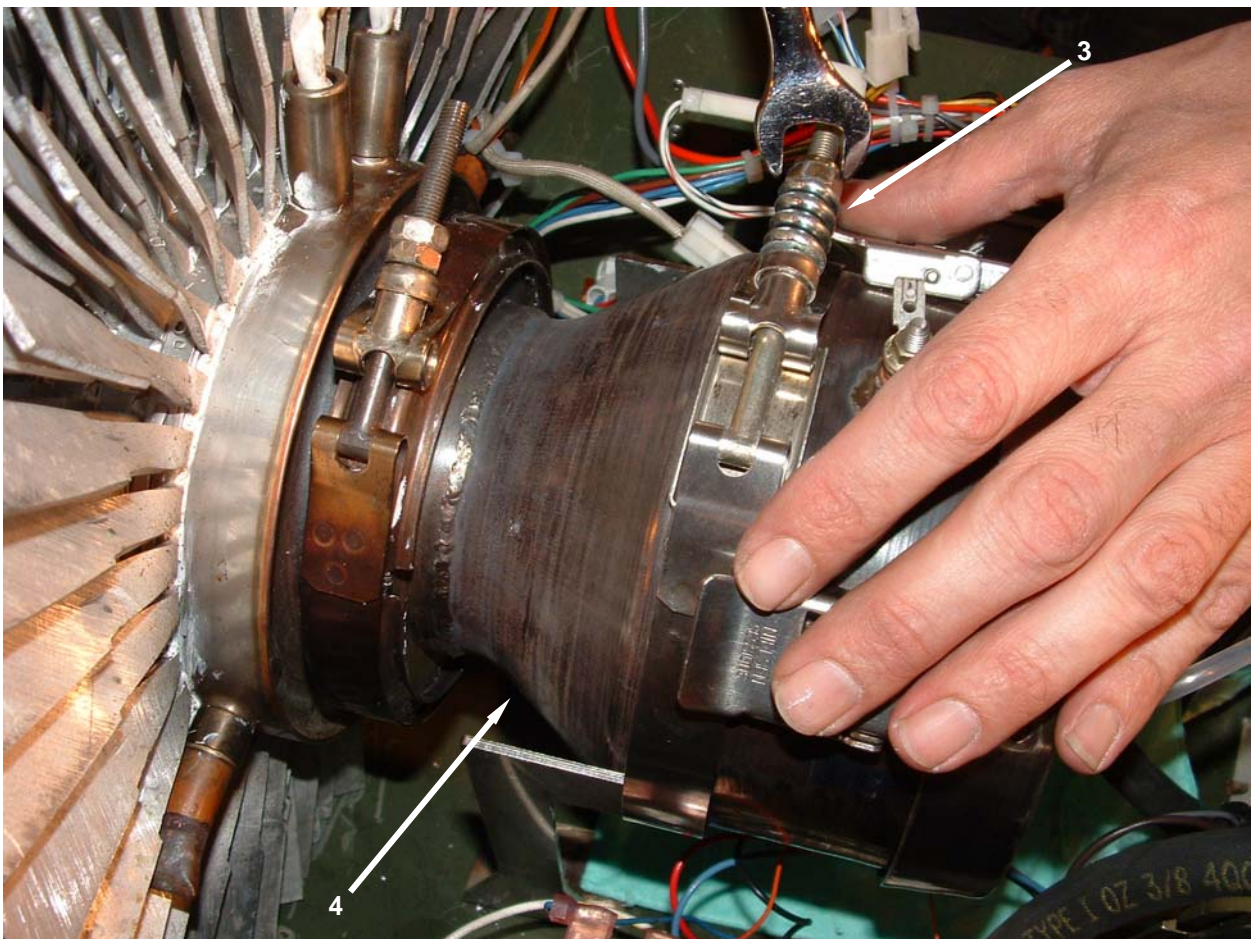
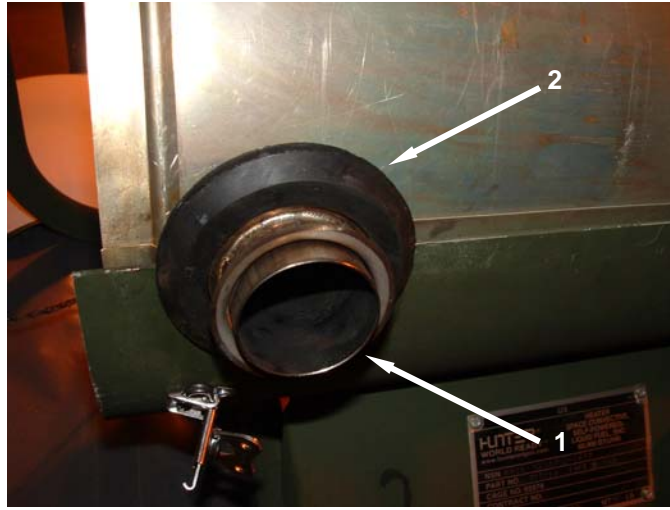

Figure 9. Replace Fin Temperature Sensor – Install Assembly.

22. Connect wires (**Figure 10, Item 1**) to modular connector (**Figure 10, Item 2**).
23. Remove tag and connect two TEG connectors (**Figure 10, Item 3**).
24. Connect the glow plug (**Figure 10, Item 4**), flame sensor (**Figure 10, Item 5**), ground wire (**Figure 10, Item 6**), fuel line (**Figure 10, Item 7**), and combustion air blower duct (**Figure 10, Item 8**) to the burner assembly (**Figure 10, Item 9**).
25. Install thermostat reset switch IAW WP 0057 00.
26. Install the upper housing IAW WP 0052 00, and install the duct adapters IAW WP 0039 00.
27. Set up and operate the heater IAW WP 0005 00 and WP 0006 00, and monitor for normal operation.

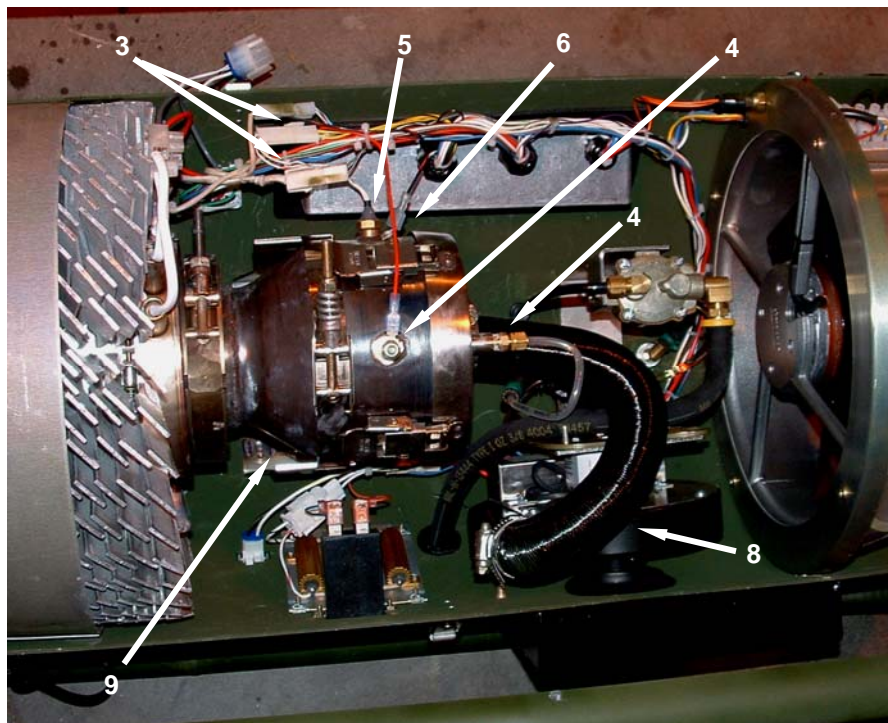
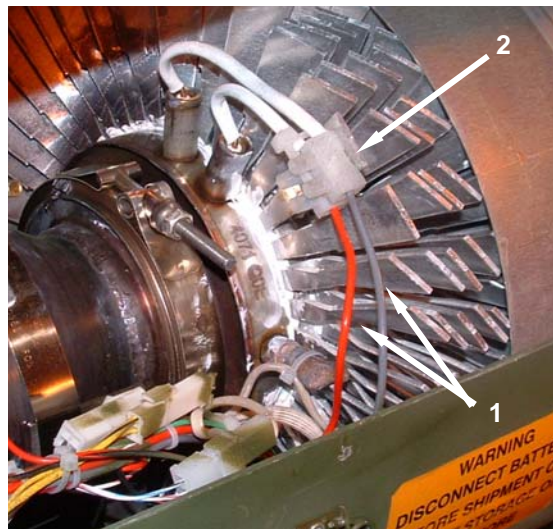

Figure 10. Replace Fin Temperature Sensor – Completion.

INSTALL**Install Thermoelectric Generator (TEG)**

1. To install the thermoelectric generator (**Figure 11, Item 1**), install fiberglass rope (**Figure 11, Item 2**) in flange grooves on both ends of the TEG, and on the flange of the heat exchanger (**Figure 11, Item 3**).



Figure 11. Install the Thermoelectric Generator – Install Fiberglass Rope.

NOTE

Refer to Figure 12 for the correct alignment of the TEG. Take note of the relative positions of the TEG modular electrical connections (at 1 o'clock), the stub tubes (at 3 o'clock and 9 o'clock respectively) and the combustion exhaust outlet (at 9 o'clock).

2. While positioning the combustion exhaust outlet (**Figure 12, Item 1** of the heat exchanger (**Figure 12, Item 2** at the 9 o'clock position, position the modular connector (**Figure 12, Item 3** at the 1 o'clock position. Align the flanges of the TEG (**Figure 13 Item 1**) and the heat exchanger.

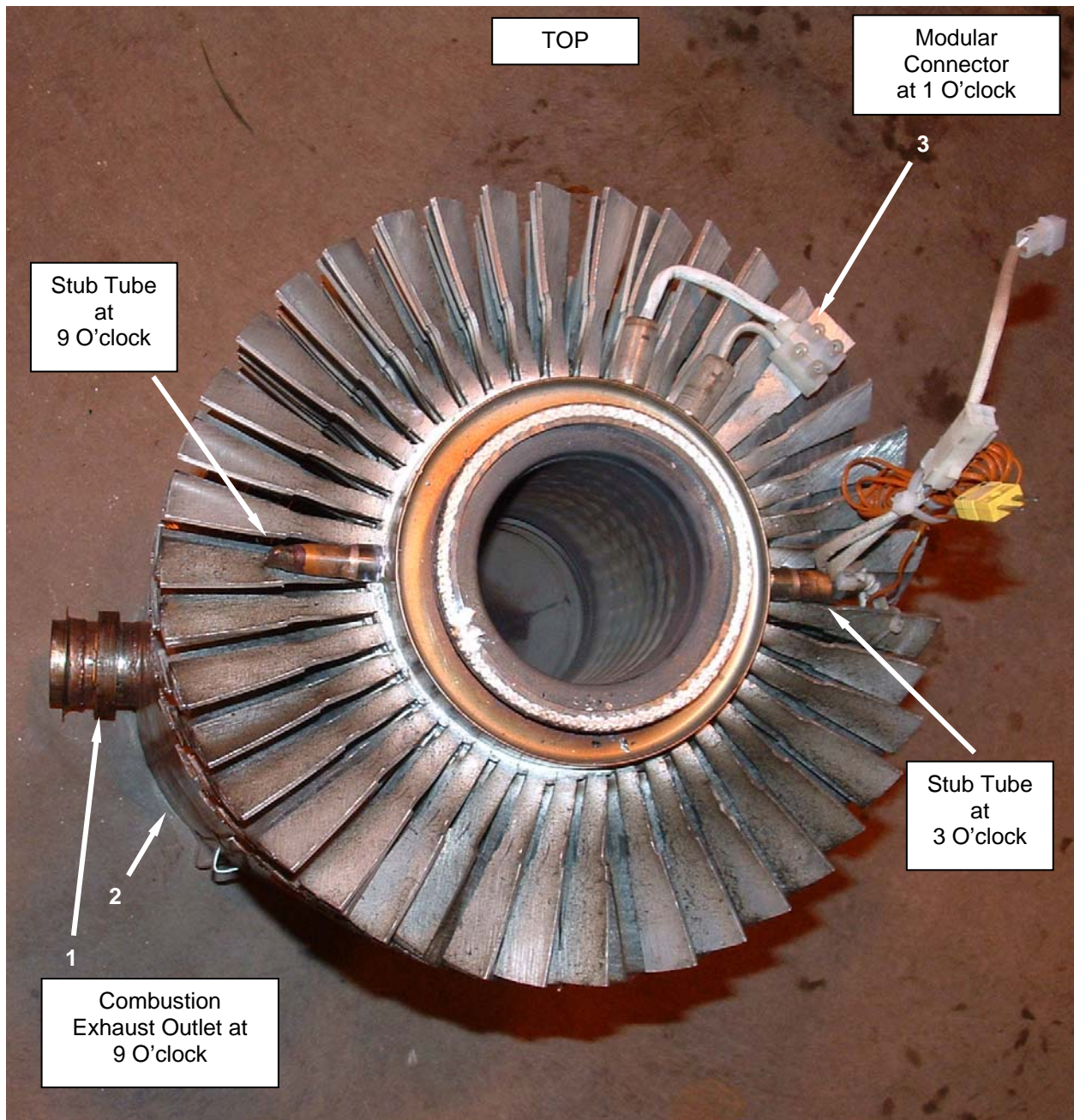

Figure 12. Install the Thermoelectric Generator – Heat Exchanger/TEG Alignment.



WARNING

Failure to properly install graphite ribbon seal may cause combustion gases to leak into inlet air stream. Carbon monoxide is present in the exhaust fumes of any fuel-burning heater. Carbon monoxide is a gas without color, smell, or taste, but can still kill you. Breathing carbon monoxide may produce symptoms of headache, dizziness, loss of muscular control, a sleepy feeling, and unconsciousness or coma. Death or brain damage may result from exposure.

3. Install new graphite ribbon tape (**Figure 13, Item 2**) around the outside of the junction of the TEG (**Figure 13, Item 1**) and heater exchanger (**Figure 13, Item 3**) flanges. Be sure to overlap the tape by approximately 2 to 3 inches. Roll tape over edges of both flanges to ensure a good seal.
4. Install flange clamp (**Figure 13, Item 4**) taking care to position the top of the clamp so that it is aligned just to the left of the modular connector (**Figure 13, Item 5**). Tighten the clamp securely.

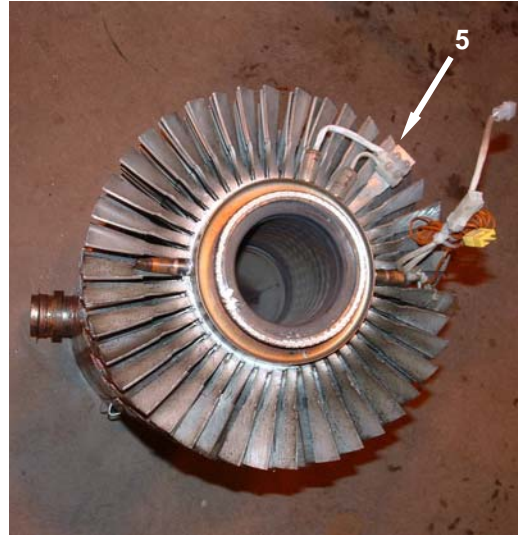
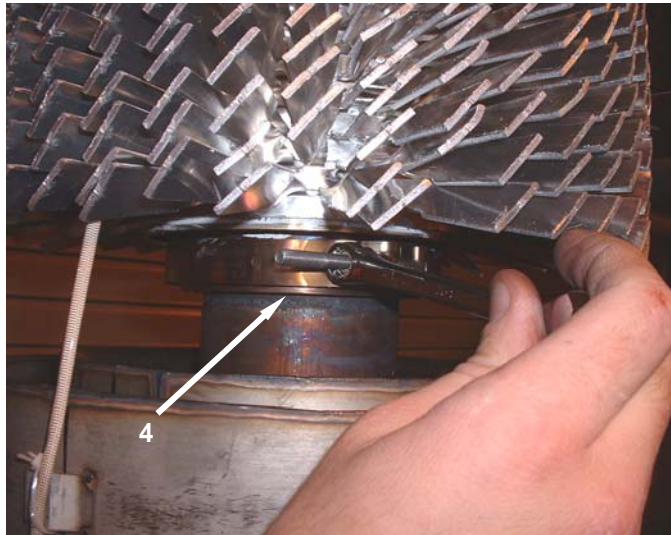
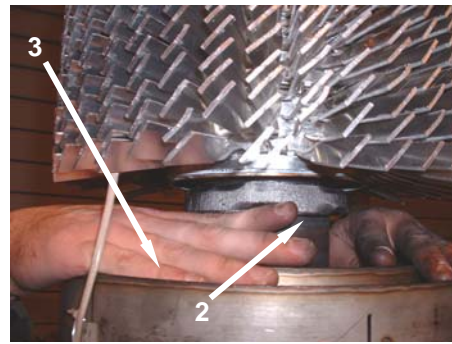
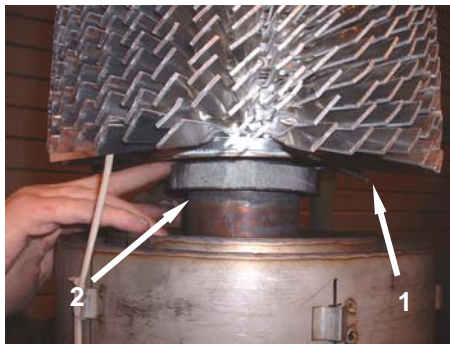

Figure 13. Install the Thermoelectric Generator – Heat Exchanger/TEG Connection.

5. Align cutouts in wrap cover (**Figure 14, Item 1**) with the combustion exhaust outlet (**Figure 14, Item 2**) and position around the heat exchanger (**Figure 14, Item 3**). Ensure that the wrap cover is positioned so that the thermostat reset switch, when installed, can be installed through the hole in the wrap cover and mounted to the bracket in the lower housing assembly.
6. While holding the wrap cover (**Figure 14, Item 1**) securely in position, install sheet metal screws (**Figure 14, Item 4**) and washers. Tighten all screws securely.
7. Install exhaust grommet (**Figure 14, Item 10**) over combustion exhaust outlet (**Figure 14, Item 2**).



Figure 14. Install the Thermoelectric Generator – Install Wrap Cover.

NOTE

Correct assembly of the burner assembly to the TEG will have the glow plug aligned with the top position as indicated in Figure 6.

8. Install the burner assembly (**Figure 15, Item 1**) in position on the TEG flange taking care to align the glow plug (**Figure 15, Item 2**) on the burner assembly in the installed 12 o'clock position.

**WARNING**

Failure to properly install graphite ribbon seal may cause combustion gases to leak into inlet air stream. Carbon monoxide is present in the exhaust fumes of any fuel-burning heater. Carbon monoxide is a gas without colour, smell, or taste, but can still kill you. Breathing carbon monoxide may produce symptoms of headache, dizziness, loss of muscular control, a sleepy feeling, and unconsciousness or coma. Death or brain damage may result from exposure.

9. Install new graphite ribbon tape (**Figure 15, Item 3**) around the burner assembly (**Figure 15, Item 1**) and TEG (**Figure 15, Item 4**) flanges. Be sure to overlap the tape two to three inches. Roll tape over edges of both flanges to ensure a good seal.
10. Install flange clamp (**Figure 15, Item 5**) over burner assembly (**Figure 15, Item 1**) and TEG (**Figure 15, Item 4**) flanges taking care to position the top of the clamp at the installed 12 o'clock position. Do not rotate clamp after installing new graphite ribbon tape. Tighten the flange clamp securely.

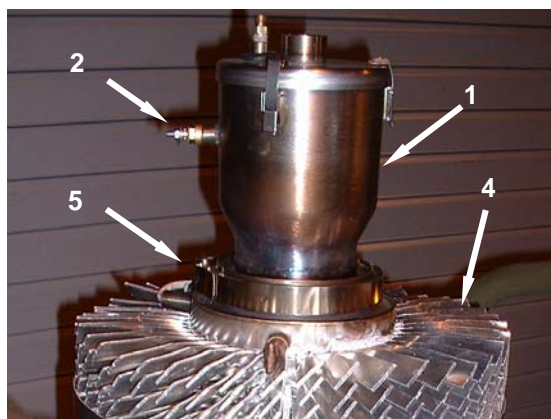
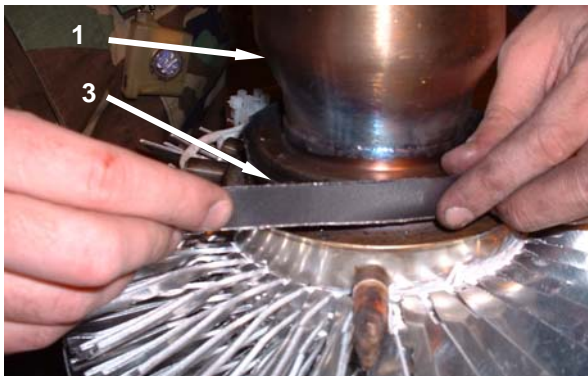

Figure 15. Install the Thermoelectric Generator – Install Burner.

11. Place assembled heat exchanger, TEG, and burner assembly (**Figure 16, Item 1**) into heater and align combustion exhaust outlet (**Figure 16, Item 2**) and grommet (**Figure 16, Item 3**) with the cutout in the lower housing assembly. Be sure to engage the groove in the grommet with the cutout in the lower housing assembly.
12. Tighten clamp (**Figure 16, Item 4**) retaining burner assembly (**Figure 16, Item 5**).

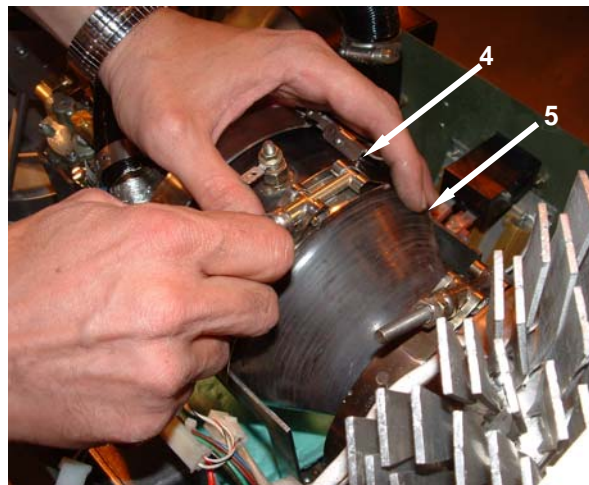
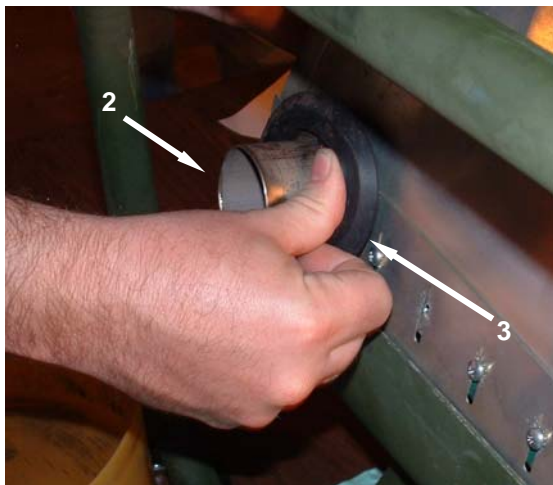
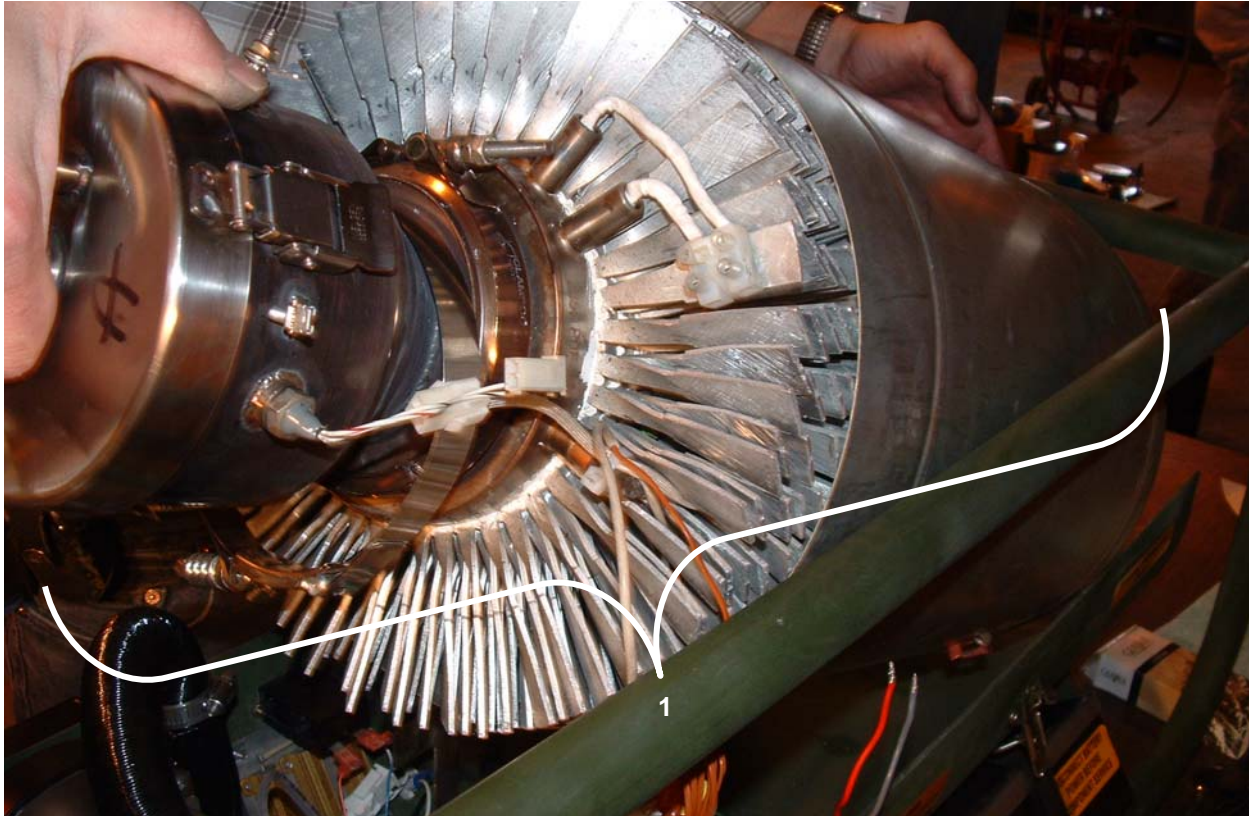

Figure 16. Install the Thermoelectric Generator – Install into Heater.

13. Reconnect wires (**Figure 17, Item 1**) to TEG modular connector (**Figure 17, Item 2**).
14. Reconnect two TEG connectors (**Figure 17, Item 3**).
15. Reconnect the glow plug (**Figure 17, Item 4**), flame sensor (**Figure 17, Item 5**), ground wire (**Figure 17, Item 6**), fuel line (**Figure 17, Item 7**), and combustion air blower hose (**Figure 17, Item 8**) to the burner assembly (**Figure 17, Item 9**).
16. Install thermostat reset switch IAW WP 0057 00.
17. Install the upper housing IAW WP 0052 00, and install the duct adapters IAW WP 0039 00.
18. Set up and operate the heater IAW WP 0005 00 and WP 0006 00, and monitor for normal operation.

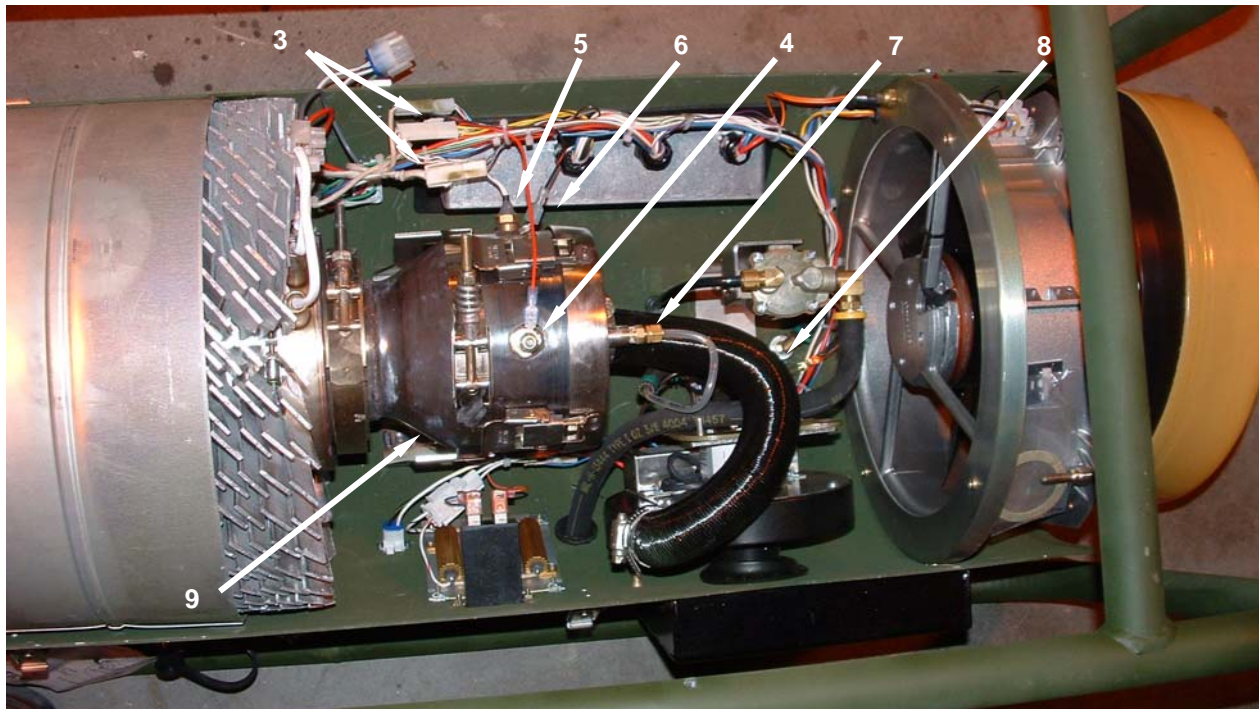
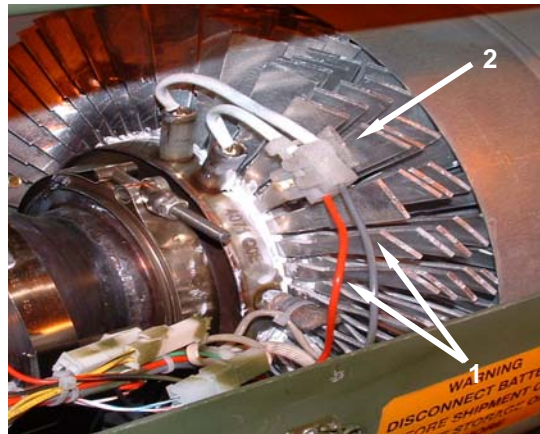

Figure 17. Install the Thermoelectric Generator (TEG) – Conclusion.

END OF WORK PACKAGE

**UNIT MAINTENANCE
SPACE HEATER, CONVECTIVE 60K BTU (SHC-60K)
NSN 4520-01-520-6477
HEAT EXCHANGER
REMOVE, SERVICE, INSPECT, TEST, INSTALL**

INITIAL SETUP:**Tools**

Tool Kit, General Mechanic's (Item 1, WP 0067 00)

Personnel Required

Two

Materials/Parts

Alcohol, Isopropyl (Item 2, WP 0092 00)
Baled Rag, General (Item 3, WP 0092 00)
Mat, Petroleum Absorbent (Item 11, WP 0092 00)
Wire Markers (Item 19, WP 0092 00)

Equipment Condition

Heater shut down, Cool, and all advisory lights off. (WP 0006 00)
In-tent controller assembly disconnected from heater. (WP 0006 00)
Fuel supply disconnected. (WP 0006 00)
Battery disconnected. (WP 0043 00)
Upper housing assembly removed. (WP 0052 00)

REMOVE**Remove Heat Exchanger****WARNING**

Be sure to disconnect battery connector before performing any maintenance procedures. Failure to do so may cause sparking or short circuits which might cause a fire or damage heater components.

NOTE

Manage and dispose of fuel and fuel absorbent pads or wipes in accordance with appropriate state, local, and installation environmental regulations.

1. Place a section of petroleum absorbent mat in the bottom of the lower housing assembly under the burner assembly in order to catch any fuel that may spill. Wipe up any spilled fuel with a rag.
2. Remove manual thermostat reset switch as described in WP 0057 00 and set aside.
3. Tag and disconnect the glow plug wire (**Figure 1, Item 1**), flame sensor connector (**Figure 1, Item 2**), ground wire (**Figure 1, Item 3**), fuel line (**Figure 1, Item 4**), and combustion air blower hose (**Figure 1, Item 5**) from the burner assembly (**Figure 1, Item 6**).
4. Tag and disconnect the two TEG electrical connectors (**Figure 1, Items 7**).
5. Tag and disconnect the two wires (**Figure 2, Item 8**) going into the modular connector (**Figure 2, Item 9**) on the side of the TEG by loosening the two bottom screws. Do not loosen the top screws for the wires that enter the interior of the TEG.

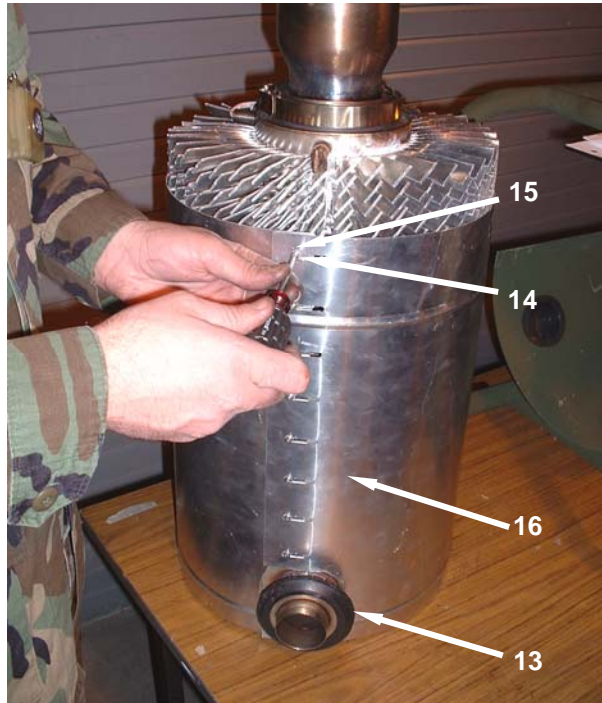
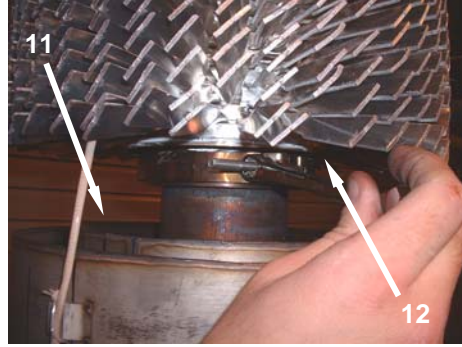
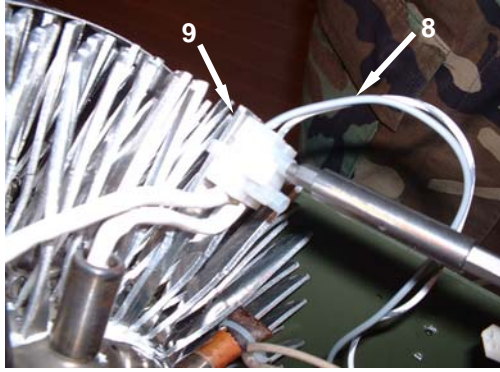

Figure 2. Remove Heat Exchanger – Continued.

SERVICE**Clean the Heat Exchanger Assembly****WARNING**

Isopropyl alcohol is flammable, toxic, and hazardous to eyes, skin, and respiratory tract. Impervious hand and eye protection is required. Avoid unprotected, repeated, or prolonged contact. If contact with eyes is made, immediately flush with clean water seek medical attention. Use only in well ventilated areas. Keep away from open flames or other sources of ignition.

Using rags and isopropyl alcohol, clean the exterior of all accessible features of the heat exchanger assembly (**Figure 3, Item 1**).

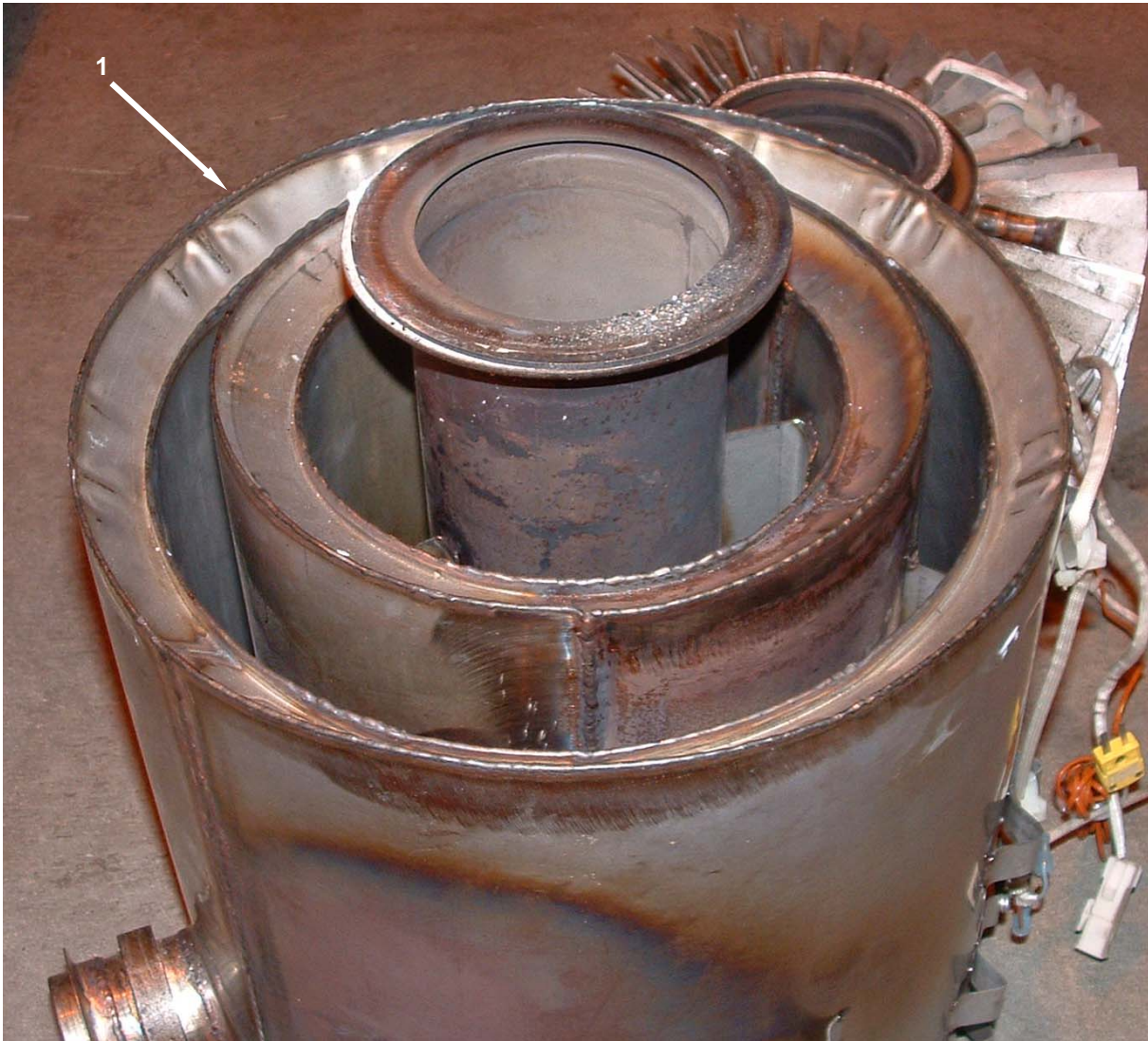

Figure 3. Clean the Heat Exchanger Assembly.

INSPECT**Inspect the Heat Exchanger Assembly**

1. Using a flashlight or, if available, a 5X or 10X magnifier, inspect all surfaces of the heat exchanger for any indication of cracks or corrosion that penetrate parent metal.

**WARNING**

Failure to properly inspect all welds for leaks may cause combustion gases to leak into inlet air stream. Carbon monoxide is present in the exhaust fumes of any fuel burning heater. Carbon monoxide is a gas without color, smell, or taste that can kill you. Breathing carbon monoxide may produce symptoms of headache, dizziness, loss of muscular control, a sleepy feeling, and unconsciousness or coma. Death or brain damage may result from exposure.

2. All welds must be inspected thoroughly. Typical welded areas are indicated in the accompanying illustration and are represented by (W). A heat exchanger that leaks may present a hazard to personnel within the tent being heated.
3. Minor surface corrosion that does not penetrate the parent metal may be removed with a wire brush.
4. If any indication of cracks is found, replace the heat exchanger assembly.
5. If any corrosion appears to penetrate the parent metal, replace the heat exchanger assembly.

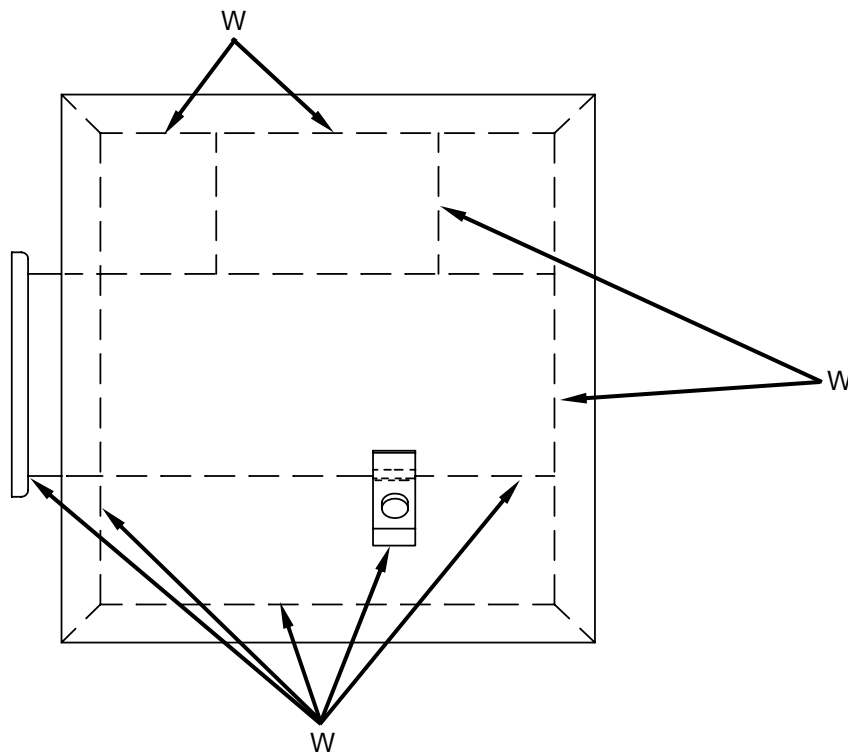

Figure 4. Inspect the Heat Exchanger Assembly.

INSTALL

Install the Heat Exchanger Assembly

1. First, the thermoelectric generator (TEG) (**Figure 5, Item 1**) must be installed. Install fiberglass rope (**Figure 5, Item 2**) in TEG flange groove (**Figure 5, Item 3**) and heat exchanger flange (**Figure 5, Item 4**).

NOTE

Refer to Figure 6 for the correct alignment of the TEG. Take note of the relative positions of the TEG modular electrical connections (at 1 o'clock), the stub tubes (at 3 o'clock and 9 o'clock respectively) and the combustion exhaust outlet (at 9 o'clock).

2. While positioning the combustion exhaust outlet (**Figure 5, Item 5**) of the heat exchanger at the 9 o'clock position, position the two input wires (**Figure 5, Item 6**) exiting the TEG at the 1 o'clock position. Align and mate the TEG flange (**Figure 5, Item 3**) and heat exchanger flange (**Figure 5, Item 4**).



WARNING

Failure to install graphite ribbon seal may cause combustion gases to leak into inlet air stream. Carbon monoxide is present in the exhaust fumes of any fuel burning heater. Carbon monoxide is a gas without color, smell, or taste that can kill you. Breathing carbon monoxide may produce symptoms of headache, dizziness, loss of muscular control, a sleepy feeling, and unconsciousness or coma. Death or brain damage may result from exposure.

3. Install new graphite ribbon tape (**Figure 5, Item 7**) around the outside of the TEG flange (**Figure 5, Item 3**) and heater exchanger flange (**Figure 5, Item 4**). Be sure to overlap the tape by approximately 2 to 3 inches. Roll tape over edges of both flanges to ensure a good seal.
4. Install flange clamp (**Figure 5, Item 8**) over TEG flange (**Figure 5, Item 3**) and heater exchanger flange (**Figure 5, Item 4**) taking care to position the top of the clamp so that it is aligned just to the left of the two input wires (**Figure 5, Item 6**) exiting the TEG. Tighten the clamp securely.
5. Align cutouts in wrap cover (**Figure 5, Item 9**) with the combustion exhaust outlet (**Figure 5, Item 5**) and position around the heat exchanger (**Figure 5, Item 10**). Ensure that the wrap cover is positioned so that the thermostat reset switch, when installed, can be installed through the hole in the wrap cover and mounted to the bracket in the lower housing assembly. Also, ensure that the two wires and connectors (**Figure 5, Item 11**) tied to outside of the heat exchanger hang out of the hole in the wrap cover.
6. While holding the wrap cover (**Figure 5, Item 9**) securely in position, install sheet metal screws (**Figure 5, Item 12**) and washers (**Figure 5, Item 13**). Tighten all screws securely.
7. Install exhaust grommet (**Figure 5, Item 14**) over combustion exhaust outlet (**Figure 5, Item 5**).

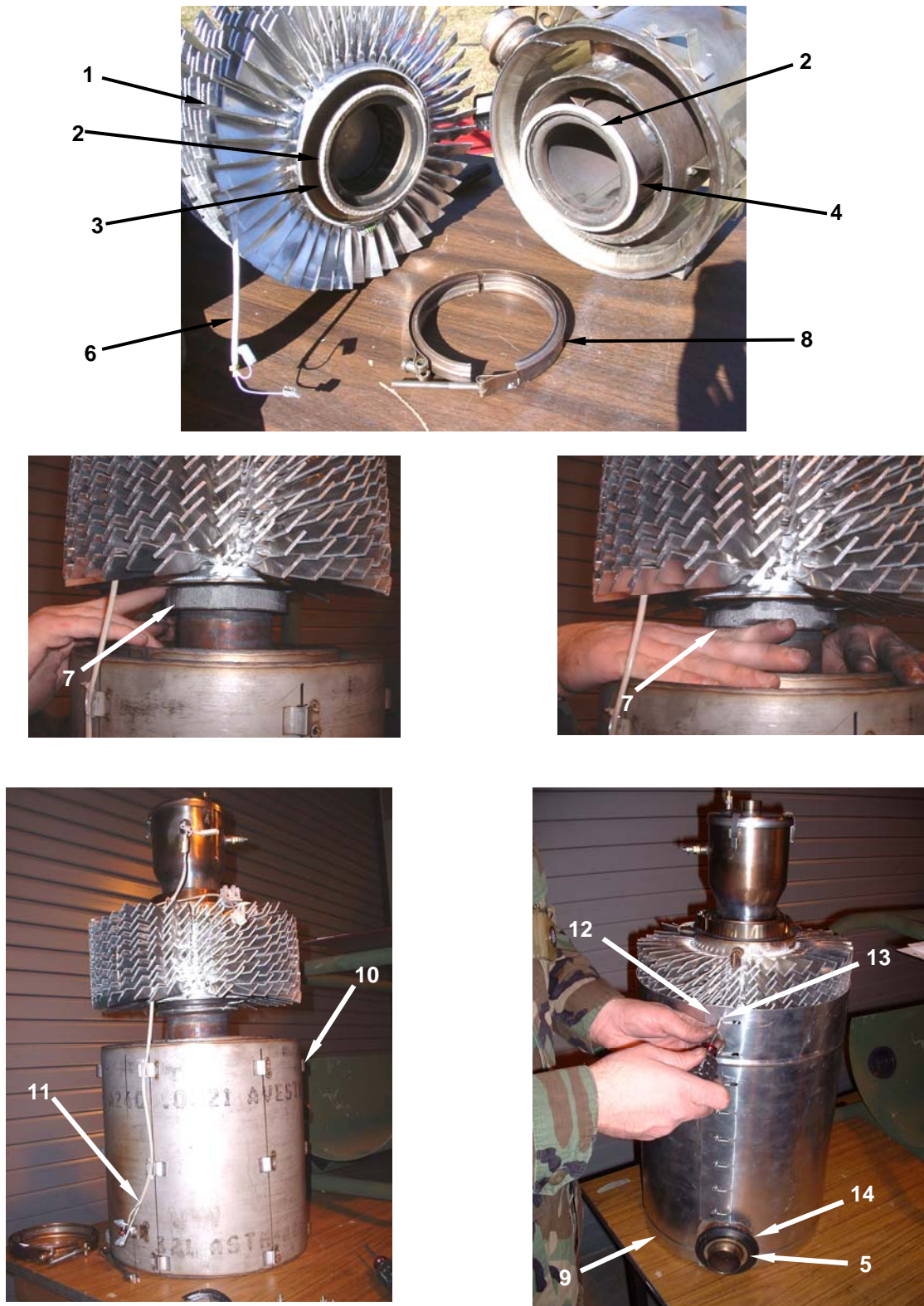

Figure 5. Install Heat Exchanger.

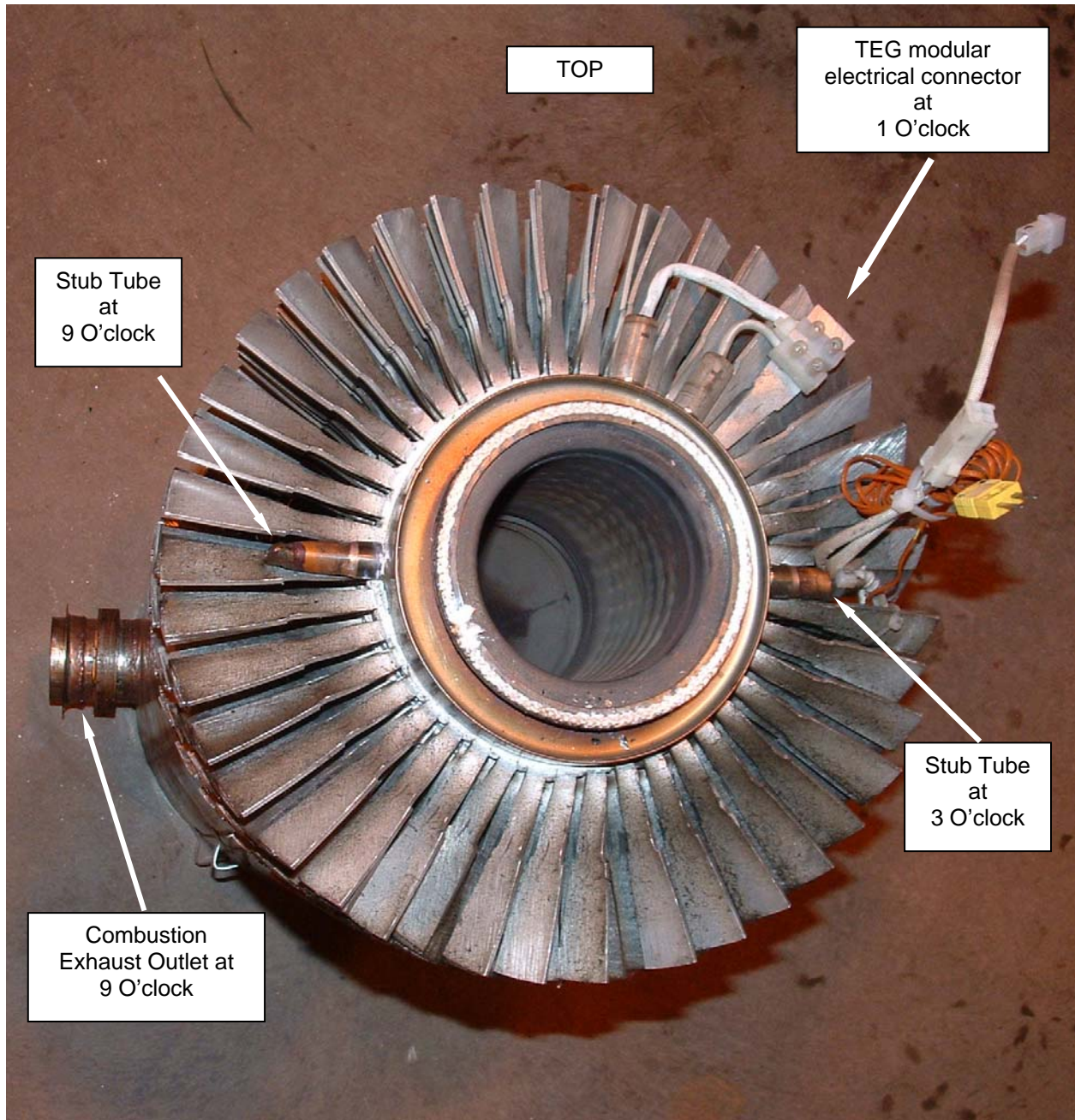

Figure 6. Install Thermoelectric Generator (TEG) to Heat Exchanger – Correct Alignment.

8. Place assembled heat exchanger, TEG, and burner assembly into heater and align combustion exhaust outlet (**Figure 7, Item 1**) and grommet (**Figure 7, Item 2**) with the exhaust cutout (**Figure 7, Item 3**) in lower housing. Be sure to engage the groove (**Figure 7, Item 4**) in the grommet with the cutout (**Figure 7, Item 3**) in the lower housing assembly.
9. Tighten clamp (**Figure 7, Item 5**) retaining burner assembly (**Figure 7, Item 6**).
10. Remove tag and connect wires (**Figure 7, Item 7**) to TEG cooling fin temperature sensor modular connector (**Figure 7, Item 8**).
11. Remove tag and connect two TEG connectors (**Figure 7, Item 9 and 10**).
12. Remove tag connect the glow plug wire (**Figure 7, Item 11**), flame sensor connector (**Figure 7, Item 12**), ground wire (**Figure 7, Item 13**), fuel line (**Figure 7, Item 14**), and combustion air blower hose (**Figure 7, Item 15**) to the burner assembly (**Figure 7, Item 6**).
13. Install thermostat reset switch IAW WP 0057 00.
14. Install the upper housing IAW WP 0052 00, and install the duct adapters IAW WP 0039 00.
15. Set up and operate the heater IAW WP 0005 00 and WP 0006 00, and monitor for normal operation.

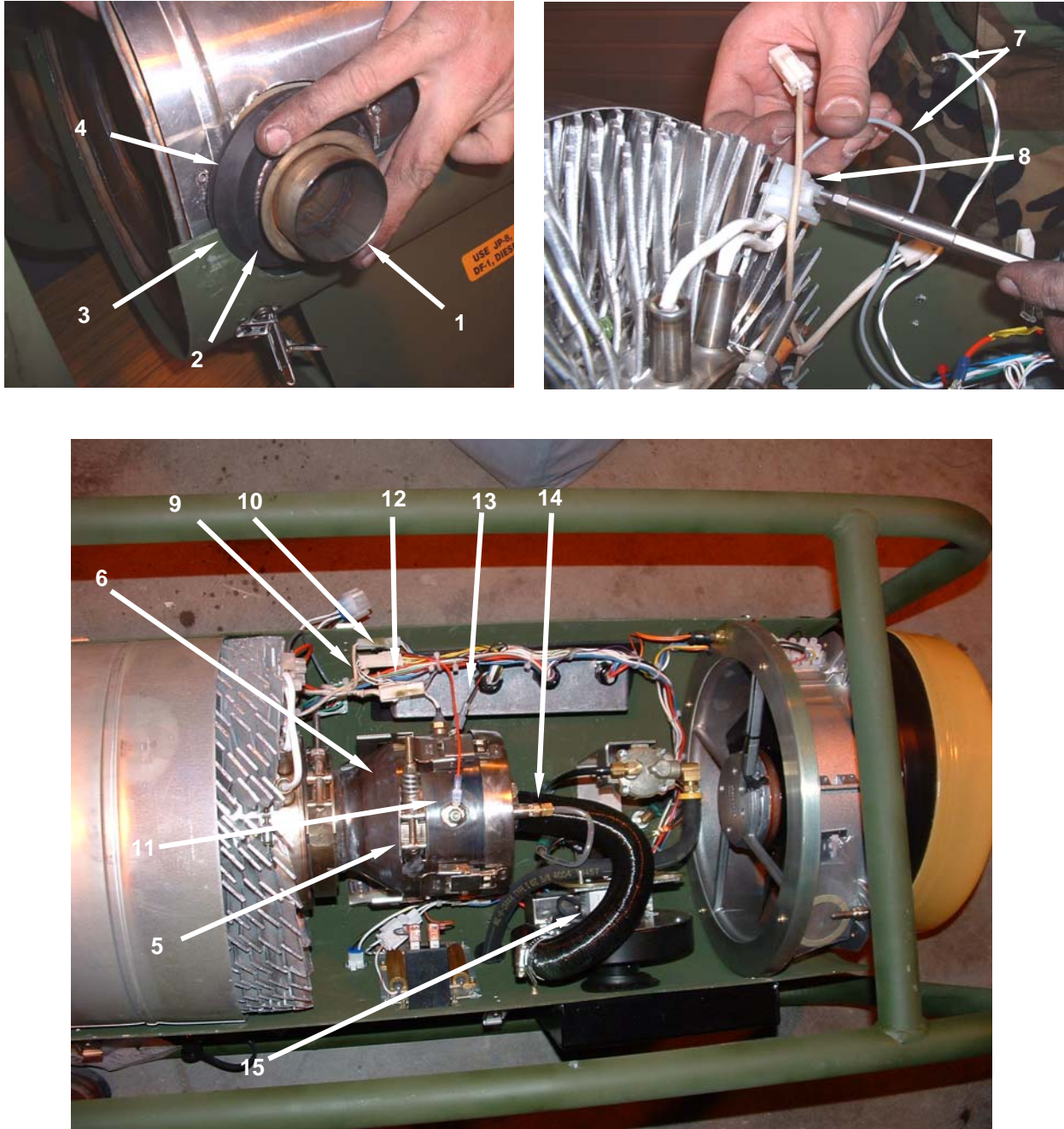

Figure 7. Install Heat Exchanger – Conclusion.

END OF WORK PACKAGE

UNIT MAINTENANCE
SPACE HEATER, CONVECTIVE 60K BTU (SHC-60K)
NSN 4520-01-520-6477
LOWER HOUSING ASSEMBLY
SERVICE, REPAIR

INITIAL SETUP:**Tools**

Tool Kit, General Mechanics (Item 1, WP 0067 00)
Drill Set (Item 6, WP 0067 00)
Riveting Tool (Item 7, WP 0067 00)

Personnel Required

One

Materials/Parts

Silicone lubricant (Item 10, WP 0092 00)

Equipment Condition

Heater shut down, cool, and all advisory lights off (WP 0006 00).

SERVICE

Lubricate slide portion (**Figure 1, Item 1**) and pivot (**Figure 1, Item 2**) of adjusting handle (**Figure 1, Item 3**) with silicone lubricant.

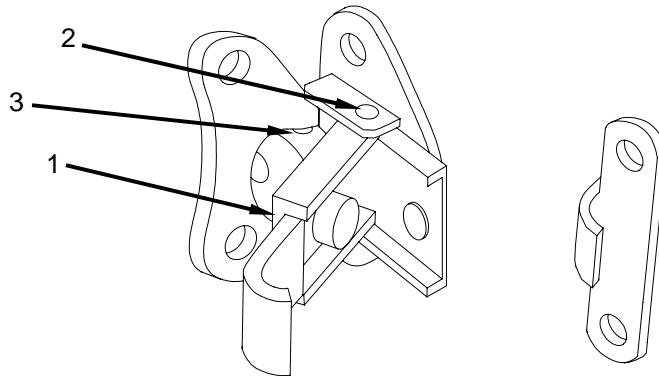

Figure 1. Lubricate.

REPAIR**Repair the Lower Housing Assembly****WARNING**

Eye protection must be worn when performing this maintenance task. Proper eye protection will significantly reduce the risk of eye injury. Failure to observe this safety precaution could result in serious eye injury or blindness.

CAUTION

Select a drill sized the same size as the rivet hole or smaller. The correct size may be determined by comparing the drill to the replacement rivet. Using an oversized drill may enlarge the rivet hole, affecting alignment of the fastener.

1. To repair the lower housing assembly by replacing a catch (**Figure 2, Item 1**), first drill out the rivets (**Figure 2, Item 2**) retaining the fastener halves to the housing.
2. Install the catch (**Figure 2, Item 1**) to the housing using the riveting tool and rivets (**Figure 2, Item 2**).
3. Operate the fastener (**Figure 2, Item 1**) to ensure that the halves align correctly.



Figure 2. Repair the Lower Housing Assembly.

END OF WORK PACKAGE

**UNIT MAINTENANCE
SPACE HEATER, CONVECTIVE 60K BTU (SHC-60K)
NSN 4520-01-520-6477
RETURN AND SUPPLY DUCTS WITH DEBRIS GRILLS
INSPECT, REPAIR**

INITIAL SETUP:**Tools**

None required

Personnel Required

One

Materials/Parts

Tape, Duct (Item 15, WP 0092 00)

Equipment Condition

Heater shut down and all advisory lights off (WP 0006 00).

NOTE

The following procedures apply to both, the return and/or supply ducts and debris grills.

INSPECT

1. Inspect the return and supply ducts (**Figure 1, Item 1**) for cuts, abrasions, or other damage that would permit air to enter or exit the side walls of the ducts. Repair any rips or cuts in the duct before using.
2. Inspect the debris grills (**Figure 1, Item 2**) for dents or other damage that would impair the free flow of air into or out of the duct. Replace any debris grills that are damaged.

REPAIR

1. To repair rips, tears, or cuts in the fabric covering of the duct (**Figure 1, Item 1**), cover with at least two layers of duct or similar tape, overlapping the edges of the cut or tear by at least two inches.
2. If damage to the duct (**Figure 1, Item 1**) is excessive and it is not practical to repair with tape, the duct should be replaced.



Figure 1. Return and Supply Ducts.

END OF WORK PACKAGE

CHAPTER 5
SUPPORTING INFORMATION
SPACE HEATER, CONVECTIVE 60K BTU (SHC-60K)

**OPERATOR'S AND UNIT MAINTENANCE MANUAL
SPACE HEATER, CONVECTIVE 60K BTU (SHC-60K)
NSN 4520-01-520-6477
REFERENCES**

SCOPE

This work package lists all field manuals, technical manuals, forms, pamphlets, Army regulations, and military this manual.

FIELD MANUALS

Chemical and Biological Contamination Avoidance	FM 3-3
NBC Protection	FM 3-4
NBC Decontamination	FM 3-5
First Aid for Soldiers	FM 21-11

TECHNICAL MANUALS

Destruction of Army Materiel to Prevent Enemy Use	TM 750-244-3
Inspection, Care, and Maintenance of Antifriction Bearings	TM 9-214
Painting Instructions for Army Materiel w/C1-C3 encl.	TM 43-0139
Battery Disposition and Disposal	TB 43-0134

FORMS

Recommended Changes to Publications and Blank Forms	DA Form 2028
Equipment Inspection and Maintenance Worksheet	DA Form 2404
Product Quality Deficiency Report	SF 368

MISCELLANEOUS

The Army Maintenance Management System (TAMMS)	DA Pam 750-8
Functional Users Manual for the Army Maintenance Management System	DA Pam 738-751
Expendable/Durable Items	CTA 50-970
Army Medical Dept. Expendable/Durable Items	CTA 8-100
Army Logistics Readiness and Sustainability	AR 700-138

**OPERATOR'S AND UNIT MAINTENANCE
SPACE HEATER, CONVECTIVE 60K BTU (SHC-60K)
NSN 4520-01-520-6477
MAINTENANCE ALLOCATION CHART (MAC) INTRODUCTION**

INTRODUCTION

The Army Maintenance System MAC

This introduction provides a general explanation of all maintenance and repair functions authorized at the two maintenance levels under the Two-Level Maintenance System concept.

The MAC (immediately following the introduction) designates overall authority and responsibility for the performance of maintenance functions on the identified end item or component. The application of the maintenance functions to the end item or component shall be consistent with the capacities and capabilities of the designated maintenance levels, which are shown on the MAC in column (4) as:

Field - includes three subcolumns, Crew maintenance (C), Service maintenance (O), and Field maintenance (F).

Sustainment – includes two subcolumns, General Support (H) and Depot (D).

The tools and test equipment requirements (immediately following the MAC) list the tools and test equipment (both special tools and common tool sets) required for each maintenance function as referenced from the MAC.

The remarks (immediately following the tools and test equipment requirements) contain supplemental instructions and explanatory notes for a particular maintenance function.

Maintenance Functions

Maintenance functions are limited to and defined as follows:

1. Inspect. To determine the serviceability of an item by comparing its physical, mechanical, and/or electrical characteristics with established standards through examination (e.g., by sight, sound, or feel.) This includes scheduled inspection and gagings and evaluation of cannon tubes.
2. Test. To verify serviceability by measuring the mechanical, pneumatic, hydraulic, or electrical characteristics of an item and comparing those characteristics with prescribed standards on a scheduled basis, i.e., load testing of lift devices and hydrostatic testing of pressure hoses.
3. Service. Operations required periodically to keep an item in proper operating condition, e.g. to clean (includes decontaminate, when required), to preserve, to paint, to drain, to replenish fuel, lubricants, chemical fluids, or gases. This includes scheduled exercising and purging of recoil mechanisms. The following are examples of service functions:
 - a. Unpack. To remove from packing box for service or when required for the performance of maintenance operations.
 - b. Repack. To return item to packing box after service and other maintenance operations.
 - c. Clean. To rid the item of contamination.
 - d. Touch up. To spot paint scratched or blistered surfaces.
 - e. Mark. To restore obliterated identification.
4. Adjust. To maintain or regulate, within prescribed limits, by bringing into proper or position, or by setting the operating characteristics to specified parameters.

5. Align. To adjust specified variable elements of an item to bring about optimum or desired performance
6. Calibrate. To determine and cause corrections to be made or to be adjusted on instruments of test, measuring, and diagnostic equipment used in precision measurement. Consists of comparisons of two instruments, one of which is a certified standard of known accuracy, to detect and adjust any discrepancy in the accuracy of the instrument being compared.
7. Remove/install. To remove and install the same item when required to perform service or other maintenance functions. Install may be the act of emplacing, seating, or fixing into position a spare, repair part, or module (component or assembly) in a manner to allow the proper functioning of an equipment or system.
8. Paint. To prepare and spray color coats of paint so that the ammunition can be identified and protected. The color indicating primary use is applied, preferably, to the entire exterior surface as the background color of the item. Other markings are to be repainted as original so as to retain proper ammunition identification.
9. Replace. To remove an unserviceable item and install a serviceable counterpart in its place. "Replace" is authorized by the MAC and assigned maintenance level is shown as the third position code of the Source, Maintenance and Recoverability (SMR) code.
10. Repair. The application of maintenance services, including fault location/troubleshooting, removal/installation, disassembly/assembly procedures and maintenance actions to identify troubles and restore serviceability to an item by correcting specific damage, fault, malfunction, or failure in a part, subassembly, module (component or assembly), end item, or system.

NOTE

The following definitions are applicable to the "repair" maintenance function: Services. Inspect, test, service, adjust, align, calibrate, and/or replace.

Fault location/troubleshooting. The process of investigating and detecting the cause of equipment malfunctioning; the act of isolating a fault within a system or Unit Under Test (UUT).

Disassembly/assembly. The step by step breakdown (taking apart) of a spare/functional group coded item to the level of its least component, that is assigned an SMR code for the level of maintenance under consideration (i.e. identified as maintenance significant).

Actions. Welding, grinding, riveting, straightening, facing, machining, and/or resurfacing.

11. Overhaul. That maintenance effort (service/action) prescribed to restore an item to a completely serviceable/operational condition as required by maintenance standards in appropriate technical publications. Overhaul is normally the highest degree of maintenance performed by the Army. Overhaul does not normally return an item to like new condition.

12. Rebuild. Consists of those services/actions necessary for the restoration of unserviceable equipment to a like new condition in accordance with original manufacturing standards. Rebuild is the highest degree of material maintenance applied to Army equipment. The rebuild operation includes the act of returning to zero those age measurements (e.g., hours/miles) considered in classifying Army equipment/components.

Explanation of Columns in the MAC

Column (1) Group Number. Column (1) lists Functional Group Code (FGC) numbers, the purpose of which is to identify maintenance significant components, assemblies, subassemblies, and modules with the Next Higher Assembly (NHA).

Column (2) Component/Assembly. Column (2) contains the item names of components, assemblies, subassemblies, and modules for which maintenance is authorized.

Column (3) Maintenance Function. Column (3) lists the functions to be performed on the item listed in column (2). (For a detailed explanation of these functions refer to "Maintenance Functions" outlined above).

Column (4) Maintenance Level. Column (4) specifies each level of maintenance authorized to perform each function listed in column (3), by indicating work time required (expressed as manhours in whole hours or decimals) in the appropriate subcolumn. This work time figure represents the active time required to perform that maintenance function at the indicated level of maintenance. If the number or complexity of the tasks within the listed maintenance function varies at different maintenance levels, appropriate work time figures are to be shown for each level. The work time figure represents the average time required to restore an item (assembly, subassembly, component, module, end item, or system) to a serviceable condition under typical field operating conditions. This time includes preparation time (including any necessary disassembly/assembly time), troubleshooting/fault location time, and quality assurance time in addition to the time required to perform the specific tasks identified for the maintenance functions authorized in the MAC. The symbol designations for the various maintenance levels are as follows:

Field:

- C Operator or Crew maintenance
- O Service maintenance
- F Field maintenance

Sustainment:

- H Below Depot
- D Depot

Column (5) Tools and Equipment Reference Code. Column (5) specifies, by code, those common tool sets (not individual tools), common Test, Measurement and Diagnostic Equipment (TMDE), and special tools, special TMDE, and support special equipment required to perform the designated function. Codes are keyed to the entries in the tools and test equipment table.

Column (6) Remarks Code. When applicable, this column contains a letter code, in alphabetic order, which is keyed to the remarks table entries.

Explanation of Columns in the Tools and Test Equipment Requirements

Column (1) – Tool or Test Equipment Reference Code. The tool or test equipment reference code correlates with a code used in column (5) of the MAC.

Column (2) – Maintenance Level. The lowest level of maintenance authorized to use the tool or test equipment.

Column (3) – Nomenclature. Name or identification of the tool or test equipment.

Column (4) – National Stock Number (NSN). The NSN of the tool or test equipment.

Column (5) – Tool Number. The manufacturer's part number.

Explanation of Columns in Remarks

Column (1) – Remarks Code. The code recorded in column (6) of the MAC.

Column (2) – Remarks. This column lists information pertinent to the maintenance function being performed as indicated in the MAC.

**UNIT MAINTENANCE
SPACE HEATER, CONVECTIVE, 60K BTU (SHC-60K)
NSN 4520-01-520-6477
MAINTENANCE ALLOCATION CHART (MAC)**

Table 1. Maintenance Allocation Chart for Space Heater, Convective (SHC), 60K BTU.

(1) GROUP NUMBER	(2) COMPONENT/ ASSEMBLY	(3) MAINTENANCE FUNCTION	(4) MAINTENANCE LEVEL					(5) TOOLS AND EQUIPMENT REFERENCE CODE	(6) REMARKS CODE
			FIELD			SUSTAINMENT			
			CREW	SERVICE	FIELD	BELOW DEPOT	DEPOT		
			C	O	F	H	D		
00	SPACE HEATER, CONVECTIVE 60K BTU								
01	IN-TENT CONTROLLER SYSTEM	Inspect Test	0.1	0.1 0.2			1		
0101	IN-TENT CONTROLLER	Inspect Test Replace	0.1	0.1 0.2 0.1			1		
0102	IN-TENT CONTROLLER CABLE	Inspect Test Replace	0.1	0.1 0.2 0.1			1		
02	BATTERY PACK SYSTEM	Inspect Test Repair	0.1 0.1	0.1 0.1			1	B,D	
0201	BATTERY PACK	Inspect Test Service Replace	0.1 0.5	0.1 0.1 0.5 0.2			1 1,3,4,5 1		
0202	LOAD BANK	Inspect Test Replace		0.1 0.1 0.1			1 1		
03	EXTERNAL FUEL SYSTEM	Inspect	0.3	0.3					
0301	FUEL SUPPLY QUICK DISCONNECT	Inspect Replace	0.1	0.1 0.2			1		
0302	FUEL SOLENOID VALVE AND SEDIMENT STRAINER ASSEMBLY	Inspect Test Service Replace	0.1 0.2 0.2	0.1 0.1 0.5			1 1 1	A,C,D	
0303	FUEL HOSE	Inspect Replace	0.1	0.1 0.3			1		
04	ELECTRONIC BOX ASSEMBLY COMPLETE WITH WIRE HARNESS	Inspect Repair Replace	0.4	0.2 0.2 0.8			1		
0401	ELECTRONIC BOX ASSEMBLY	Inspect Repair Replace	0.1	0.1 0.2 1.0			1 1 1		

Table 1. Maintenance Allocation Chart for Space Heater, Convective (SHC), 60K BTU – continued.

(1) GROUP NUMBER	(2) COMPONENT/ ASSEMBLY	(3) MAINTENANCE FUNCTION	(4) MAINTENANCE LEVEL					(5) TOOLS AND EQUIPMENT REFERENCE CODE	(6) REMARKS CODE
			FIELD			SUSTAINMENT			
			CREW	SERVICE	FIELD	BELOW DEPOT	DEPOT		
			C	O	F	H	D		
05	DUST COVER ASSEMBLY	Inspect Replace	0.1	0.1 0.2				1	
06	COMBUSTION BLOWER ASSEMBLY	Inspect	0.2						
0601	COMBUSTION AIR BLOWER ASSEMBLY	Inspect Test Replace	0.1	0.2 0.3				1 1	
0602	COMBUSTION AIR BLOWER DUCTING	Inspect Replace	0.1	0.1 0.2				1	
0603	COMBUSTION AIR INLET ASSEMBLY	Inspect Replace	0.1	0.3				1	
07	UPPER HOUSING ASSEMBLY	Inspect Service Repair Replace	0.1	0.1 0.2				1,6,7	
08	EXHAUST GROMMET	Inspect Replace	0.1	0.2				1	
09	DUCT ADAPTERS	Inspect Replace	0.1 0.1					1,6,7	
10	HEATED AIR BLOWER ASSEMBLY	Inspect Test Replace	0.1	0.1 0.1 0.3				1 1	
11	INLET AIR TEMPERATURE SENSOR	Replace		0.1				1	E
12	INTERNAL FUEL SYSTEM	Inspect Service	0.2	0.5					
1201	FUEL PUMP ASSEMBLY	Inspect Test Replace	0.1	0.2 0.5				1 1	
1202	MANUAL THERMOSTAT RESET SWITCH	Test Replace		0.2 0.1				1 1	
1203	INTERNAL FUEL LINES	Inspect Replace	0.1	0.2				1	
1204	FLOAT ASSEMBLY	Inspect Service Replace	0.1	0.4 0.4				1 1	
13	BURNER ASSEMBLY AND RELATED COM- PONENTS	Remove Inspect Install	0.1	0.3 0.2 0.3				1 1 1	

Table 1. Maintenance Allocation Chart for Space Heater, Convective (SHC), 60K BTU – continued.

(1) GROUP NUMBER	(2) COMPONENT/ ASSEMBLY	(3) MAINTENANCE FUNCTION	(4) MAINTENANCE LEVEL					(5) TOOLS AND EQUIPMENT REFERENCE CODE	(6) REMARKS CODE
			FIELD			SUSTAINMENT			
			CREW	SERVICE	FIELD	BELOW DEPOT	DEPOT		
			C	O	F	H	D		
1301	BURNER ASSEMBLY	Remove		0.3				1	
		Inspect	0.1	0.2				1	
		Service	0.3					1	
		Replace		0.7				1	
		Install		0.3				1	
130101	WICK	Inspect	0.2						A,D
		Service	0.3						
		Replace	0.3						
1302	FLAME SENSOR	Replace	0.2				2	A,D,E	
1303	GLOW PLUG	Replace	0.2				2	A,D,E	
14	THERMO- ELECTRIC GENERATOR (TEG)	Remove		0.3				1	
		Inspect	0.1	0.2				1	
		Test		0.2				1	
		Replace		0.3				1	
		Install		0.5				1	
1401	TEG FIN TEMPERA- TURE SENSOR ASSEMBLY	Replace		1.0			1	E	
15	HEAT EXCHANGER	Remove		0.5				1	
		Service		0.2				1	
		Inspect		0.5				1	
		Install		0.7				1	
16	LOWER HOUSING ASSEMBLY	Inspect	0.1						1,6,7
		Service Repair		0.1 0.3					
1601	HOUR METER	Inspect	0.1						1
		Replace		0.1					
17	AIR RETURN AND SUPPLY DUCTS WITH DEBRIS GRILL	Inspect	0.1						
		Repair		0.1					
		Replace		0.1					
18	SPARES, TOOLS, AND ACCESS- ORIES	Inspect	0.1					D	

Table 2. Tools And Test Equipment for Space Heater, Convective, 60K BTU (SHC-60K).

(1) TOOL OR TEST EQUIPMENT REFERENCE CODE	(2) MAINTENANCE LEVEL	(3) NOMENCLATURE	(4) NATIONAL STOCK NUMBER	(5) TOOL NUMBER
1 2	O C,O	Tool Kit, General Mechanic's Wrench, 9/16 in and 12 mm (included with on-board spares and tool at inlet end of heater)	5180-00-699-5273	SC 5180-90-CL05 160088
3	O	Battery Charging Adapter (included with heater and stowed in accessory bag).	4520-01-493-2810	5-13-5593
4	O	Commercial 12V DC Battery Charger	Local Purchase	
5	C	NATO Charging System	4520-01-533-0607	53587
6	O	Drill Set	5133-00-449-6775	18103
7	O	Riveting Tool	5120-00-222-3657	41A5748

Table 3. Remarks for Space Heater, Convective 60K BTU (SHC-60K).

REMARKS CODE	REMARKS
A	Spare items and wrench are stored behind the duct adapter at the breathable air inlet end of the heater.
B	Two spare 20 amp fuses are mounted behind compartment cover.
C	A gasket and screen are supplied with rest of on-board spares and tools.
D	Replace any spares that have been used.
E	Monitored by on-board diagnostics

**UNIT MAINTENANCE
SPACE HEATER, CONVECTIVE 60K BTU (SHC-60K)
NSN 4520-01-520-6477
REPAIR PARTS AND SPECIAL TOOLS LIST (RPSTL)**

INTRODUCTION

SCOPE

This RPSTL lists and authorizes spares and repair parts; special tools; special test, measurement, and diagnostic equipment (TMDE); and other special support equipment required for performance of unit and direct support maintenance of the Space Heater, Convective, 60K BTU (SHC-60K). It authorizes the requisitioning, issue, and disposition of spares, repair parts, and special tools as indicated by the source, maintenance, and recoverability (SMR) codes.

GENERAL

In addition to the Introduction work package, this RPSTL is divided into the following work packages.

1. Repair Parts List Work Packages. Work packages containing lists of spares and repair parts authorized by this RPSTL for use in the performance of maintenance. These work packages also include parts which must be removed for replacement of the authorized parts. Parts lists are composed of functional groups in ascending alphanumeric sequence, with the parts in each group listed in ascending figure and item number sequence. Sending units, brackets, filters, and bolts are listed with the component they mount on. Bulk materials are listed by item name in FIG. BULK at the end of the work packages. Repair parts kits are listed separately in their own functional group and work package. Repair parts for reparable special tools are also listed in a separate work package. Items listed are shown on the associated illustrations.
2. Special Tools List Work Packages. Work packages containing lists of special tools, special TMDE, and special support equipment authorized by this RPSTL (as indicated by Basis of Issue (BOI) information in the DESCRIPTION AND USABLE ON CODE (UOC) column). Tools that are components of common tool sets and/or Class VII are not listed.
3. Cross-Reference Indexes Work Packages. There are two cross reference indexes work packages in this RPSTL: the National Stock Number (NSN) Index work package and the Part Number (P/N) Index work package. The National Stock Number Index work package refers you to the figure and item number. The Part Number Index work package refers you to the figure and item number.

EXPLANATION OF COLUMNS IN THE REPAIR PARTS LIST AND SPECIAL TOOLS LIST WORK PACKAGES

ITEM NO. (Column (1)). Indicates the number used to identify items called out in the illustration.

SMR CODE (Column (2)). The SMR code containing supply/requisitioning information, maintenance level authorization criteria, and disposition instruction, as shown in the following breakout:

<u>Source Code</u>	<u>Maintenance Code</u>		<u>Recoverability Code</u>
<u>XX</u>	<u>XX</u>		<u>X</u>
1st two position s: How to get an item.	3rd position: who can install, replace, or use the item.	4th position: Who can do complete repair* on the item	5th position: Who determines disposition action on unserviceable items.

*Complete Repair: Maintenance capacity, capability, and authority to perform all corrective maintenance tasks of the "Repair" function in a use/user environment in order to restore serviceability to a failed item.

Source Code. The source code tells you how you get an item needed for maintenance, repair, or overhaul of an end item/equipment. Explanations of source codes follow:

<u>Source Code</u>	<u>Application/Explanation</u>
PA PB PC PD PE PF PG	Stock items; use the applicable NSN to requisition/request items with these source codes. They are authorized to the level indicated by the code entered in the 3rd position of the SMR code.
	NOTE
	Items coded PC are subject to deterioration.
KD KF KB	Items with these codes are not to be requested/requisitioned individually. They are part of a kit which is authorized to the maintenance level indicated in the 3rd position of the SMR code. The complete kit must be requisitioned and applied.

MO-Made at unit/AVUM level MF-Made at DS/AVIM level MH-Made at GS level ML-Made at SRA MD-Made at depot	Items with these codes are not to be requisitioned/requested individually. They must be made from bulk material which is identified by the P/N in the DESCRIPTION AND USABLE ON CODE (UOC) column and listed in the bulk material group work package of the RPSTL. If the item is authorized to you by the 3rd position code of the SMR code, but the source code indicates it is made at higher level, order the item from the higher level of maintenance.
AO-Assembled by unit/AVUM level AF-Assembled by DS/AVIM level AH-Assembled by GS level AL-Assembled by SRA AD-Assembled by depot	Items with these codes are not to be requested/requisitioned individually. The parts that make up the assembled item must be requisitioned or fabricated and assembled at the level of maintenance indicated by the source code. If the 3rd position of the SMR code authorizes you to replace the item, but the source code indicates the item is assembled at a higher level, order the item from the higher level of maintenance.
XA	Do not requisition an "XA" coded item. Order the next higher assembly.(Refer to NOTE below.)
XB	If an item is not available from salvage, order it using the CAGEC and P/N.
XC	Installation drawings, diagrams, instruction sheets, field service drawings; identified by manufacturer's P/N.
XD	Item is not stocked. Order an XD-coded item through normal supply channels using the CAGEC and P/N given, if no NSN is available.

NOTE

Cannibalization or controlled exchange, when authorized, may be used as a source of supply for items with the above source codes except for those items source coded "XA" or those aircraft support items restricted by requirements of AR 750-1.

Maintenance Code. Maintenance codes tell you the level(s) of maintenance authorized to use and repair support items. The maintenance codes are entered in the third and fourth positions of the SMR code as follows:

Third Position. The maintenance code entered in the third position tells you the lowest maintenance level authorized to remove, replace, and use an item. The maintenance code entered in the third position will indicate authorization to the following levels of maintenance:

<u>Maintenance Code</u>	<u>Application/Explanation</u>
C -	Crew or operator maintenance done within unit/AVUM maintenance.
O -	Unit level/AVUM maintenance can remove, replace, and use the item.
F -	Direct support/AVIM maintenance can remove, replace, and use the item.
H -	General support maintenance can remove, replace, and use the item.
L -	Specialized repair activity can remove, replace, and use the item.
D -	Depot can remove, replace, and use the item.

Fourth Position. The maintenance code entered in the fourth position tells you whether or not the item is to be repaired and identifies the lowest maintenance level with the capability to do complete repair (perform all authorized repair functions).

NOTE

Some limited repair may be done on the item at a lower level of maintenance, if authorized by the Maintenance Allocation Chart (MAC) and SMR codes.

<u>Maintenance Code</u>	<u>Application/Explanation</u>
O -	Unit/AVUM is the lowest level that can do complete repair of the item.
F -	Direct support/AVIM is the lowest level that can do complete repair of the item.
H -	General support is the lowest level that can do complete repair of the item.
L -	Specialized repair activity (enter specialized repair activity designator) is the lowest level that can do complete repair of the item.
D -	Depot is the lowest level that can do complete repair of the item.
Z -	Non-repairable. No repair is authorized.
B -	No repair is authorized. No parts or special tools are authorized for maintenance of "B" coded item. However, the item may be reconditioned by adjusting, lubricating, etc., at the user level.

Recoverability Code. Recoverability codes are assigned to items to indicate the disposition action on unserviceable items. The recoverability code is shown in the fifth position of the SMR code as follows:

Recoverability Code	Application/Explanation
Z -	Nonreparable item. When unserviceable, condemn and dispose of the item at the level of maintenance shown in the third position of the SMR code.
O -	Reparable item. When uneconomically repairable, condemn and dispose of the item at the unit level.
F -	Reparable item. When uneconomically repairable, condemn and dispose of the item at the direct support level.
H -	Reparable item. When uneconomically repairable, condemn and dispose of the item at the general support level.
D -	Reparable item. When beyond lower level repair capability, return to depot. Condemnation and disposal of item are not authorized below depot level.
L -	Reparable item. Condemnation and disposal not authorized below Specialized Repair Activity (SRA).
A -	Item requires special handling or condemnation procedures because of specific reasons (such as precious metal content, high dollar value, critical material, or hazardous material). Refer to appropriate manuals/directives for specific instructions.

NSN (Column (3)). The NSN for the item is listed in this column.

CAGEC (Column (4)). The Commercial and Government Entity Code (CAGEC) is a five-digit code which is used to identify the manufacturer, distributor, or Government agency/activity that supplies the item.

PART NUMBER (Column (5)). Indicates the primary number used by the manufacturer (individual, company, firm, corporation, or Government activity), which controls the design and characteristics of the item by means of its engineering drawings, specifications, standards, and inspection requirements to identify an item or range of items.

NOTE

When you use an NSN to requisition an item, the item you receive may have a different P/N from the number listed.

DESCRIPTION AND USABLE ON CODE (UOC) (Column (6)). This column includes the following information:

1. The federal item name, and when required, a minimum description to identify the item.
2. P/Ns of bulk materials are referenced in this column in the line entry to be manufactured or fabricated.
3. Hardness Critical Item (HCI). A support item that provides the equipment with special protection from

electromagnetic pulse (EMP) damage during a nuclear attack.

4. The statement END OF FIGURE appears just below the last item description in column (6) for a given figure in both the repair parts list and special tools list work packages.

QTY (Column (7)). The QTY (quantity per figure) column indicates the quantity of the item used in the breakout shown on the illustration/figure, which is prepared for a functional group, subfunctional group, or an assembly. A "V" appearing in this column instead of a quantity indicates that the quantity is variable and quantity may change from application to application.

EXPLANATION OF CROSS-REFERENCE INDEXES WORK PACKAGES FORMAT AND COLUMNS

1. National Stock Number (NSN) Index Work Package.

STOCK NUMBER Column. This column lists the NSN in National item identification number (NIIN) sequence. The NIIN consists of the last nine digits of the NSN.

 NSN
 (e.g., 5385-01-574-1476)
 NIIN

When using this column to locate an item, ignore the first four digits of the NSN. However, the complete NSN should be used when ordering items by stock number.

FIG. Column. This column lists the number of the figure where the item is identified/located. The figures are in numerical order in the repair parts list and special tools list work packages.

ITEM Column. The item number identifies the item associated with the figure listed in the adjacent FIG. column. This item is also identified by the NSN listed on the same line.

2. Part Number (P/N) Index Work Package. P/Ns in this index are listed in ascending alphanumeric sequence (vertical arrangement of letter and number combinations which places the first letter or digit of each group in order A through Z, followed by the numbers 0 through 9 and each following letter or digit in like order).

PART NUMBER Column. Indicates the P/N assigned to the item.

FIG. Column. This column lists the number of the figure where the item is identified/located in the repair parts list and special tools list work packages.

ITEM Column. The item number is the number assigned to the item as it appears in the figure referenced in the adjacent figure number column."

SPECIAL INFORMATION

UOC. The UOC appears in the lower left corner of the Description Column heading. Usable on codes are shown as "UOC: ..." in the Description Column (justified left) on the first line under the applicable item/nomenclature. Uncoded items are applicable to all models. Identification of the UOCs used in the RPSTL are:

<u>Code</u>	<u>Used On</u>
FVU	SHC-60K

"Fabrication Instructions. Bulk materials required to manufacture items are listed in the bulk material functional group of this RPSTL. Part numbers for bulk material are also referenced in the Description Column of the line item entry for the item to be manufactured/fabricated. Detailed fabrication instructions for items source coded to be manufactured or fabricated are found in (enter applicable TM number).

Index Numbers. Items which have the word BULK in the figure column will have an index number shown in the item number column. This index number is a cross-reference between the NSN / P/N index work packages and the bulk material list in the repair parts list work package."

HOW TO LOCATE REPAIR PARTS

1. When NSNs or P/Ns Are Not Known.

First. Using the table of contents, determine the assembly group to which the item belongs. This is necessary since figures are prepared for assembly groups and subassembly groups, and lists are divided into the same groups.

Second. Find the figure covering the functional group or the subfunctional group to which the item belongs.

Third. Identify the item on the figure and note the number(s).

Fourth. Look in the repair parts list work packages for the figure and item numbers. The NSNs and part numbers are on the same line as the associated item numbers.

2. When NSN Is Known.

First. If you have the NSN, look in the STOCK NUMBER column of the NSN index work package. The NSN is arranged in NIIN sequence. Note the figure and item number next to the NSN.

Second. Turn to the figure and locate the item number. Verify that the item is the one you are looking for.

3. When P/N Is Known.

First. If you have the P/N and not the NSN, look in the PART NUMBER column of the P/N index work package. Identify the figure and item number.

Second. Look up the item on the figure in the applicable repair parts list work package.

OPERATOR'S AND UNIT MAINTENANCE
 SPACE HEATER, CONVECTIVE 60K BTU (SHC-60K)

NSN 4520-01-520-6477

IN-TENT CONTROLLER SYSTEM

REPAIR PARTS LIST

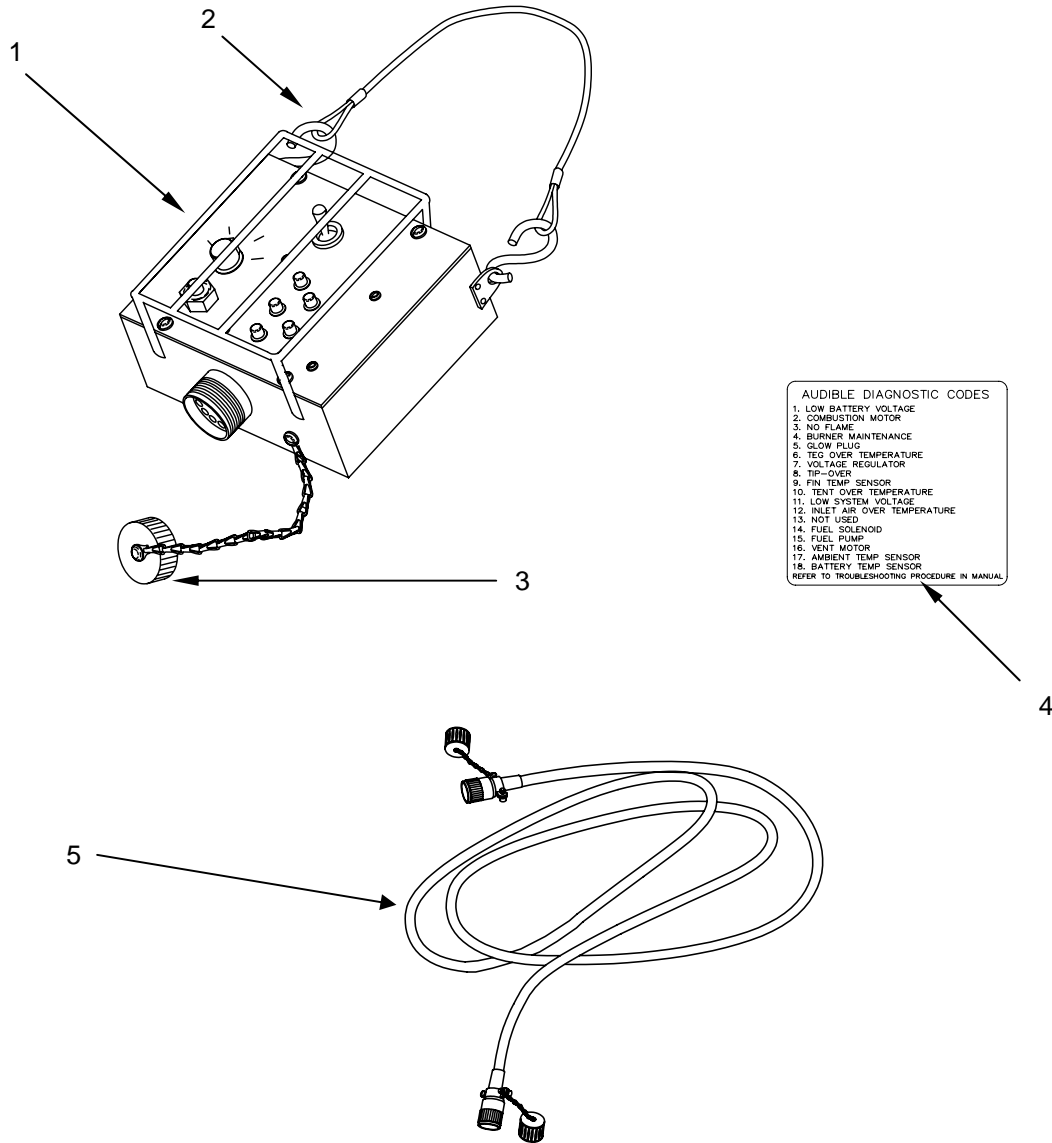

Figure 1. In-Tent Controller System.

(1) ITEM NO	(2) SMR CODE	(3) NSN	(4) CAGEC	(5) PART NO.	(6) DESCRIPTION AND USABLE ON CODE (UOC)	(7) QTY
GROUP 01 IN TENT CONTROLLER SYSTEM FIG. 1 IN TENT CONTROLLER SYSTEM						
1	PAOZZ	4520-01-547-2742	92878	160130	CONTROL BOX ASSEMBLY, PORTABLE HEATER, DUCT TYPE.....	1
2	PAOZZ	4030-00-780-9350	96906	MS87006-13	.HOOK, CHAIN, S.....	1
3	PAOZZ	5935-01-519-4930	06324	MS25043-18D	.COVER, ELECTRICAL CONNECTOR.....	1
4	XDOZZ		92878	160131	.LABEL 14 - AUDIBLE DIAGNOSTICS.....	1
5	PAOZZ	4520-01-493-2807	92878	5-13-5577	SHC IN TENT CONTROL CABLE.....	1
END OF FIGURE						

OPERATOR'S AND UNIT MAINTENANCE
SPACE HEATER, CONVECTIVE 60K BTU (SHC-60K)

NSN 4520-01-520-6477

BATTERY PACK SYSTEM

REPAIR PARTS LIST

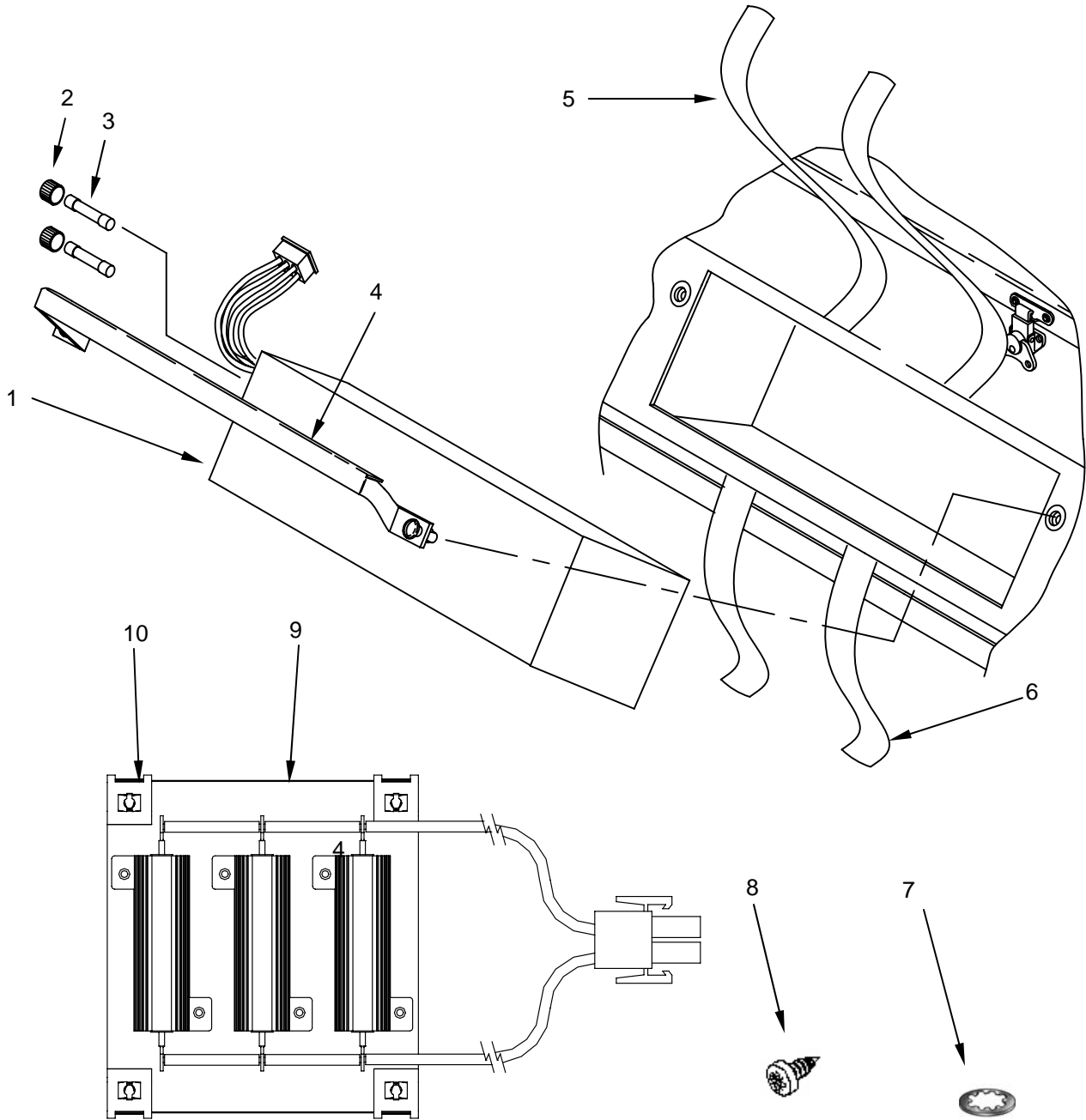

Figure 2. Battery Pack System.

(1) ITEM NO	(2) SMR CODE	(3) NSN	(4) CAGEC	(5) PART NO.	(6) DESCRIPTION AND USABLE ON CODE (UOC)	(7) QTY
GROUP 02 BATTERY PACK SYSTEM						
FIG. 2 BATTERY PACK SYSTEM						
1	PAOZZ	4520-01-493-2796	92878	5-13-5469	SHC BATTERY PACK...	1
2	PAOZZ	5920-01-547-6326	92878	160176	.CAP, FUSE HOLDER...	2
3	PAOZZ	4520-01-493-2777	92878	46273	..SHC FUSE, 20 AMP....	2
4	PAOZZ	4520-01-493-2794	92878	5-13-5468	SHC RETAINER BATTERY.....	1
5	XDOZZ		92878	160038	STRAP, BATTERY, UPPER.....	2
6	XDOZZ		92878	160037	STRAP, BATTERY, LOWER.....	2
7	PAOZZ	5310-00-559-0070	80205	MS35333-38	WASHER, LOCK, NO.8.	4
8	PAOZZ	5305-00-432-4170	96906	MS51861-35	SCREW, TAPPING, 8- 18 X 1/2IN, PAN HEAD, STAINLESS.....	4
9	PAOZZ	5985-01-550-2487	92878	160048	DUMMY LOAD ASSEMBLY.....	1
10	PAOZZ	5310-01-547-5807	78553	C-8108-8-8A-4	.SPEED NUT, U TYPE..	4
END OF FIGURE						

OPERATOR'S AND UNIT MAINTENANCE
SPACE HEATER, CONVECTIVE 60K BTU (SHC-60K)

NSN 4520-01-520-6477

EXTERNAL FUEL SYSTEM

REPAIR PARTS LIST

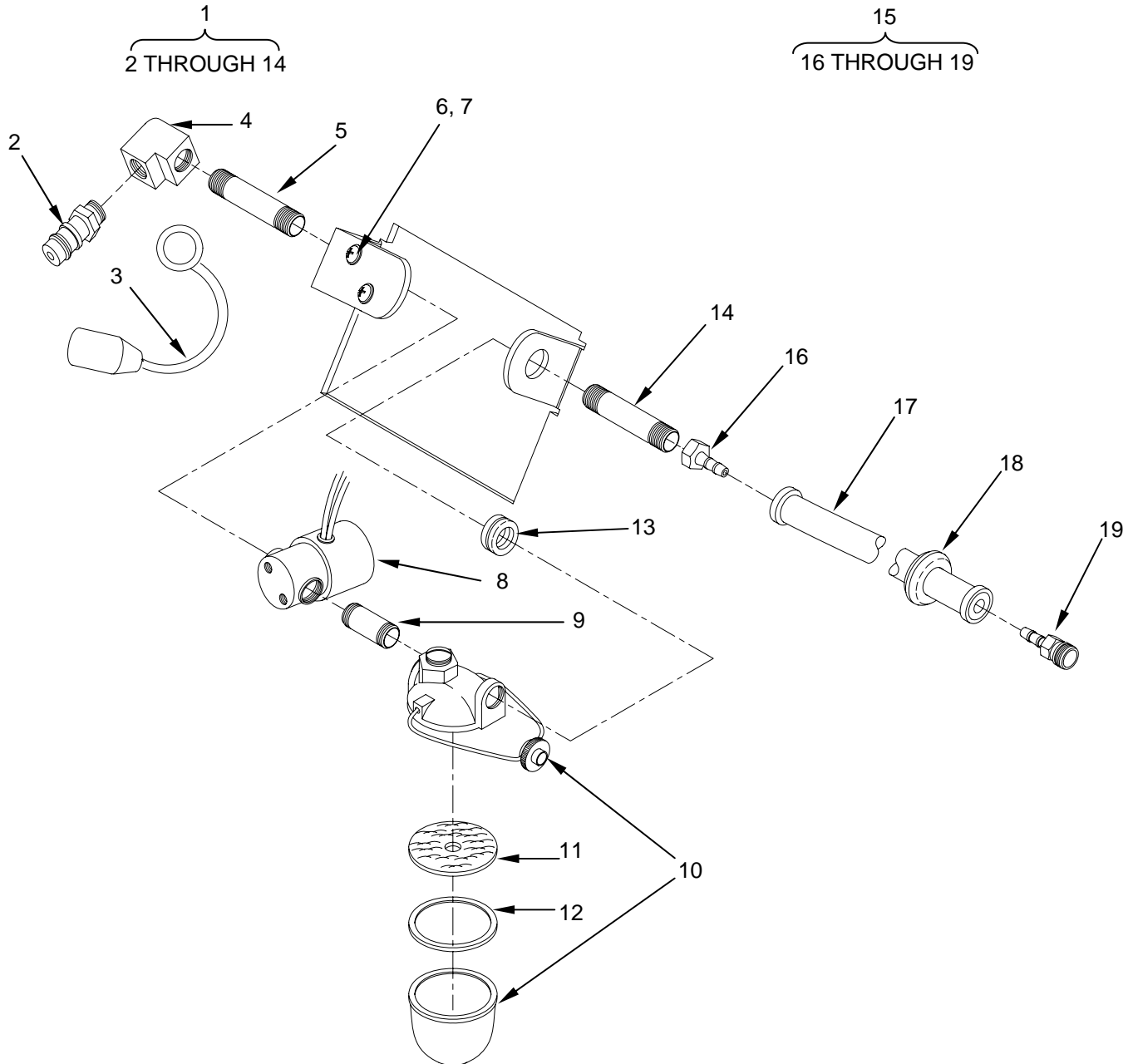

Figure 3. External Fuel System.

(1) ITEM NO	(2) SMR CODE	(3) NSN	(4) CAGEC	(5) PART NO.	(6) DESCRIPTION AND USABLE ON CODE (UOC)	(7) QT Y
GROUP 03 EXTERNAL FUEL SYSTEM						
FIG. 3 EXTERNAL FUEL SYSTEM						
1	PAOOO	5945-01-547-4585	92878	160177	SOLENOID ASSEMBLY	1
2	PAOZZ	4730-01-206-8726	73992	B-12SPECIAL 1/8IN. MPT	.PLUG QUICK DISCONNECT.....	1
3	PAOZZ	4520-01-493-2785	92878	5-13-5616	.SHC FUEL CAP ASSY..	1
4	XDOZZ		92878	1366	.ELBOW, FEMALE.....	1
5	PAOZZ	4730-00-193-2707	18876	121830	.NIPPLE, PIPE, 1 1/2IN.	1
6	PAOZZ	5305-00-889-3002	96906	MS35206-242	.SCREW, MACHINE, 8-32 X 5/16IN, PHILLIPS..	2
7	PAOZZ	5310-00-559-0070	80205	MS35333-38	.WASHER, LOCK, NO.8	2
8	PAOZZ	5945-01-547-2731	92878	160115	.SOLENOID, ELECTRICAL	1
9	PAOZZ	4730-00-230-1996	14959	3326X2	.NIPPLE, PIPE, 1/8.....	1
10	PAOZZ	2910-00-905-9792	96906	MS51086-2	.STRAINER, SEDIMENT ASSY.....	1
11	PAOZZ	4730-00-142-2738	10988	49923D	..STRAINER, ELEMENT, SEDIMENT	1
12	PAOZZ	5330-01-544-7473	1HP04	16B-185	..GASKET, FUEL STRAINER.....	1
13	PAOZZ	5325-00-291-9366	96906	MS35489-11	.GROMMET, NON- METALLIC.....	1
14	XDOZZ		92878	1321	.NIPPLE, PIPE, 2 IN.....	1
15	PAOZZ	4720-01-544-7474	92878	160024	HOSE, NONMETALLIC..	1
16	PAOZZ	4730-01-547-5745	92878	5-13-5515	.FITTING, PUSH-LOK...	1
17	XDOZZ		81349	MIL-H-13444- 1-3/8	.HOSE, 3/16 ID X 5 L .25 ID.....	1
18	PAOZZ	5325-01-544-7476	OYZF2	23824	.GROMMET, NONMETALLIC.....	1
19	PAOZZ	4730-01-547-5817	92878	5-13-5553	.FITTING, PUSH-LOK....	1
END OF FIGURE						

**OPERATOR'S AND UNIT MAINTENANCE
SPACE HEATER, CONVECTIVE 60K BTU (SHC-60K)**

NSN 4520-01-520-6477

ELECTRONIC BOX ASSEMBLY COMPLETE WITH WIRE HARNESS

REPAIR PARTS LIST

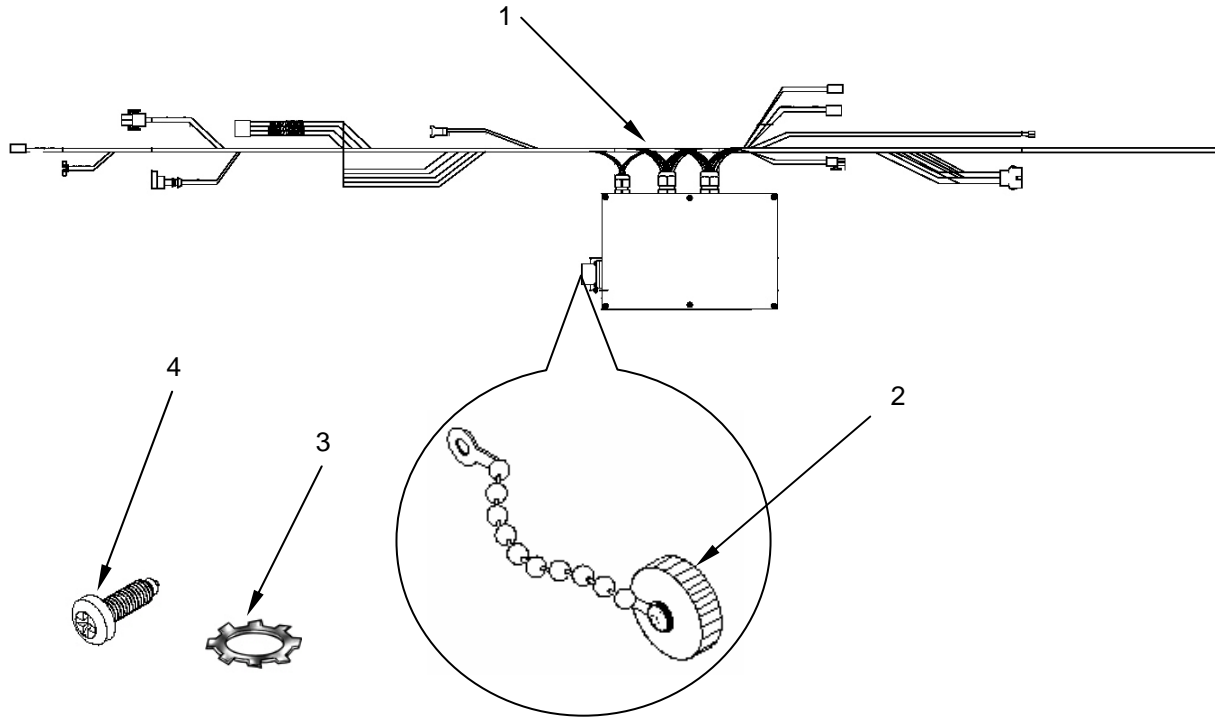

Figure 4. Electronic Box Assembly Complete with Wire Harness.

(1) ITEM NO	(2) SMR CODE	(3) NSN	(4) CAGEC	(5) PART NO.	(6) DESCRIPTION AND USABLE ON CODE (UOC)	(7) QTY
GROUP 04 ELECTRONIC BOX ASSEMBLY COMPLETE WITH WIRE HARNESS FIG. 4 ELECTRONIC BOX ASSEMBLY COMPLETE WITH WIRE HARNESS						
1	PAOZZ	5975-01-544-7477	92878	160040	ELECTRONICS BOX ASSY.....	1
2	PAOZZ	5935-01-519-4930	06324	MS25043-18D	.COVER, ELECTRICAL CONNECTOR.....	1
3	PAOZZ	5310-00-596-7691	96906	MS35335-32	.WASHER, LOCK, EXT NO. 10.....	2
4	PAOZZ	5305-00-989-7435	80205	MS35207-264	.SCREW, MACHINE 10/32 X 5/8.....	2
END OF FIGURE						

OPERATOR'S AND UNIT MAINTENANCE
SPACE HEATER, CONVECTIVE 60K BTU (SHC-60K)

NSN 4520-01-520-6477

DUST COVER ASSEMBLY

REPAIR PARTS LIST

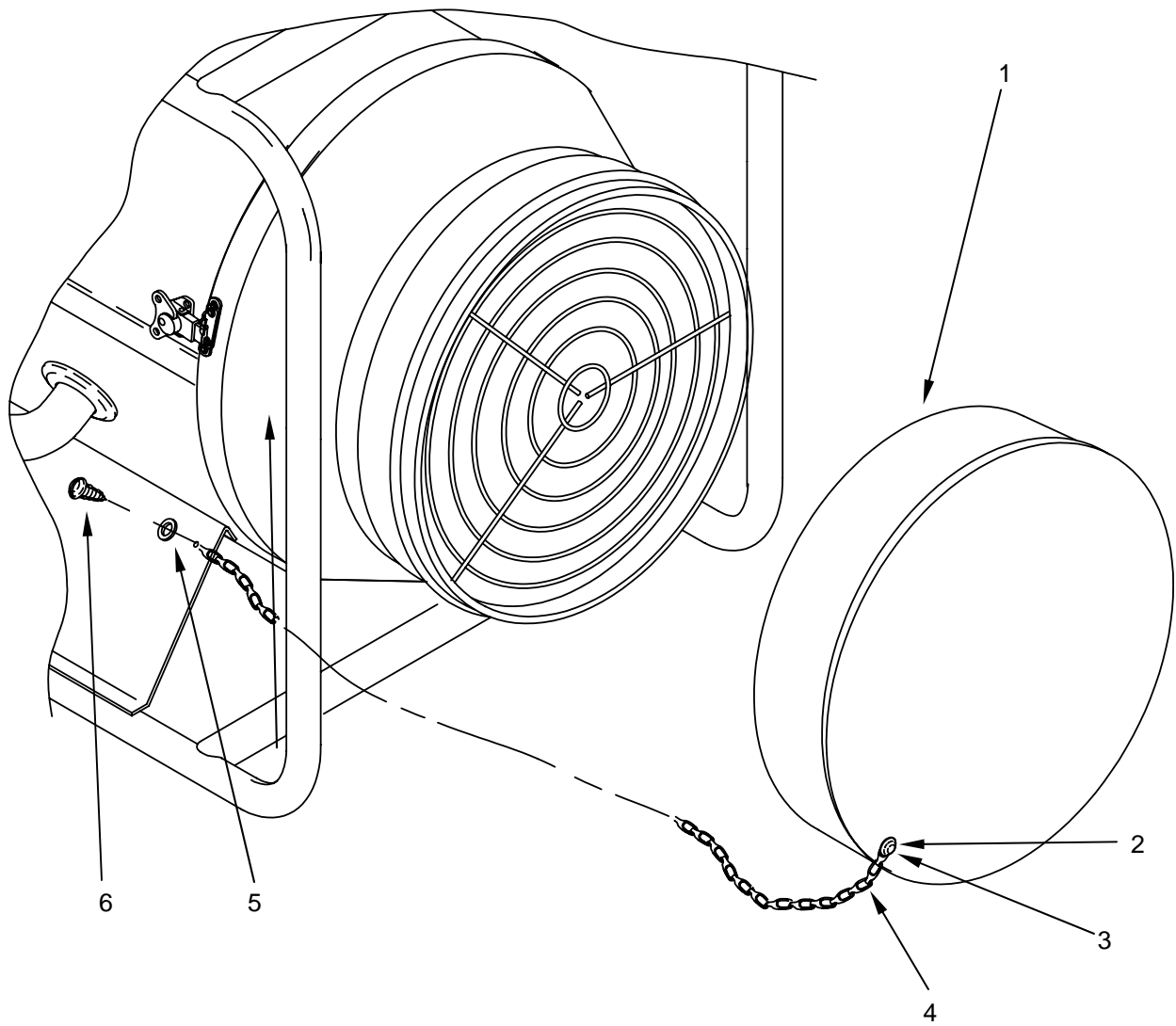

Figure 5. Dust Cover Assembly.

(1) ITEM NO	(2) SMR CODE	(3) NSN	(4) CAGEC	(5) PART NO.	(6) DESCRIPTION AND USABLE ON CODE (UOC)	(7) QTY
GROUP 05 DUST COVER ASSEMBLY FIG. 5 DUST COVER ASSEMBLY						
1	PAOZZ	5340-01-544-7478	92878	160035	COVER, PROTECTIVE, DUST AND MOISTURE	1
2	PAOZZ	5310-00-983-8483	96906	MS27183-5	.WASHER, FLAT 5/32ID.....	1
3	PAOZZ	5320-01-004-0238	81349	M24243/1D402	.RIVET, BLIND 1/8IN ID X 1/8 IN GRIP.....	1
4	MOOZZ		92878	160178	.CHAIN, WELDLESS, MAKE FROM NSN 4010-01-145-4658.....	1
5	PAOZZ	5310-00-014-5850	96906	MS27183-42	WASHER FLAT.....	1
6	PAOZZ	5305-00-984-6193	80205	MS35206-245	SCREW MACHINE.....	1
END OF FIGURE						

OPERATOR'S AND UNIT MAINTENANCE
SPACE HEATER, CONVECTIVE 60K BTU (SHC-60K)

NSN 4520-01-520-6477

COMBUSTION BLOWER ASSEMBLY

REPAIR PARTS LIST

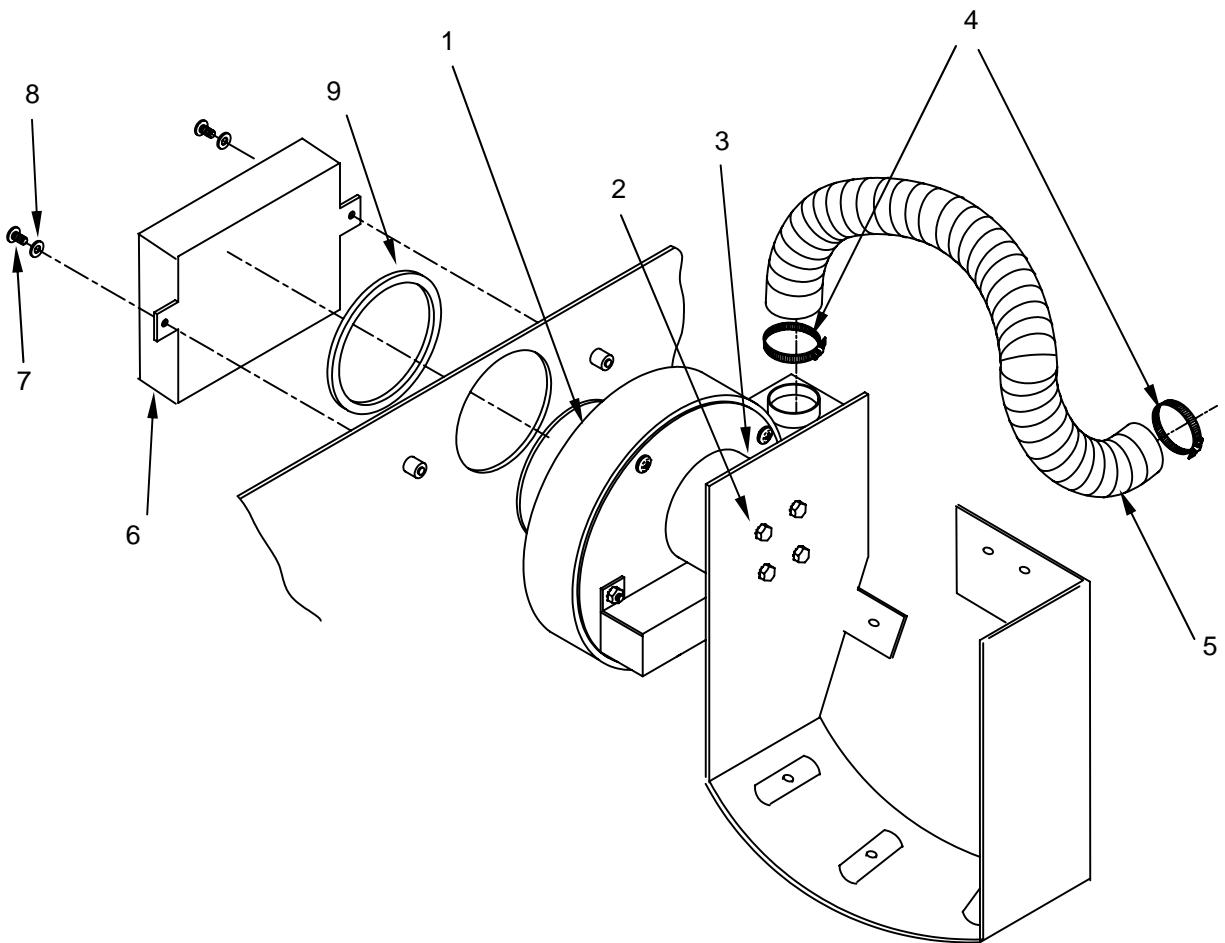

Figure 6. Combustion Blower Assembly.

(1) ITEM NO	(2) SMR CODE	(3) NSN	(4) CAGEC	(5) PART NO.	(6) DESCRIPTION AND USABLE ON CODE (UOC)	(7) QTY
GROUP 06 COMBUSTION BLOWER ASSEMBLY FIG. 6 COMBUSTION BLOWER ASSEMBLY						
1	PAOZZ	4140-01-547-2717	92878	160020	COMBUSTION AIR BLOWER ASSEMBLY...	1
2	PAOZZ	5305-01-544-7479	92878	160018	SCREW, CAP, HEXAGON HEAD, M4X6X12HHD.....	4
3	XDOZZ		92878	160085	BLOWER BRACKET ASSY.....	1
4	PAOZZ	4730-01-093-7447	81646	62P12-BA	CLAMP, HOSE.....	2
5	XDOZZ		92878	160125	DUCTING, 1.25 IN ID....	1
6	XDOZZ		92878	160025	COMBUSTION AIR INLET ASSEMBLY.....	1
7	PAOZZ	5305-00-989-7434	00198	13705	.SCREW, MACHINE, PHM 10-32 X 1/2 IN.....	2
8	PAOZZ	5310-00-067-6357	96906	MS45904-69	.WASHER, LOCK INT EXT 1/4 IN.....	2
9	PAOZZ	5325-00-970-2419	14829	1625	GROMMET.....	1
END OF FIGURE						

OPERATOR'S AND UNIT MAINTENANCE
SPACE HEATER, CONVECTIVE 60K BTU (SHC-60K)

NSN 4520-01-520-6477

UPPER HOUSING ASSEMBLY

REPAIR PARTS LIST

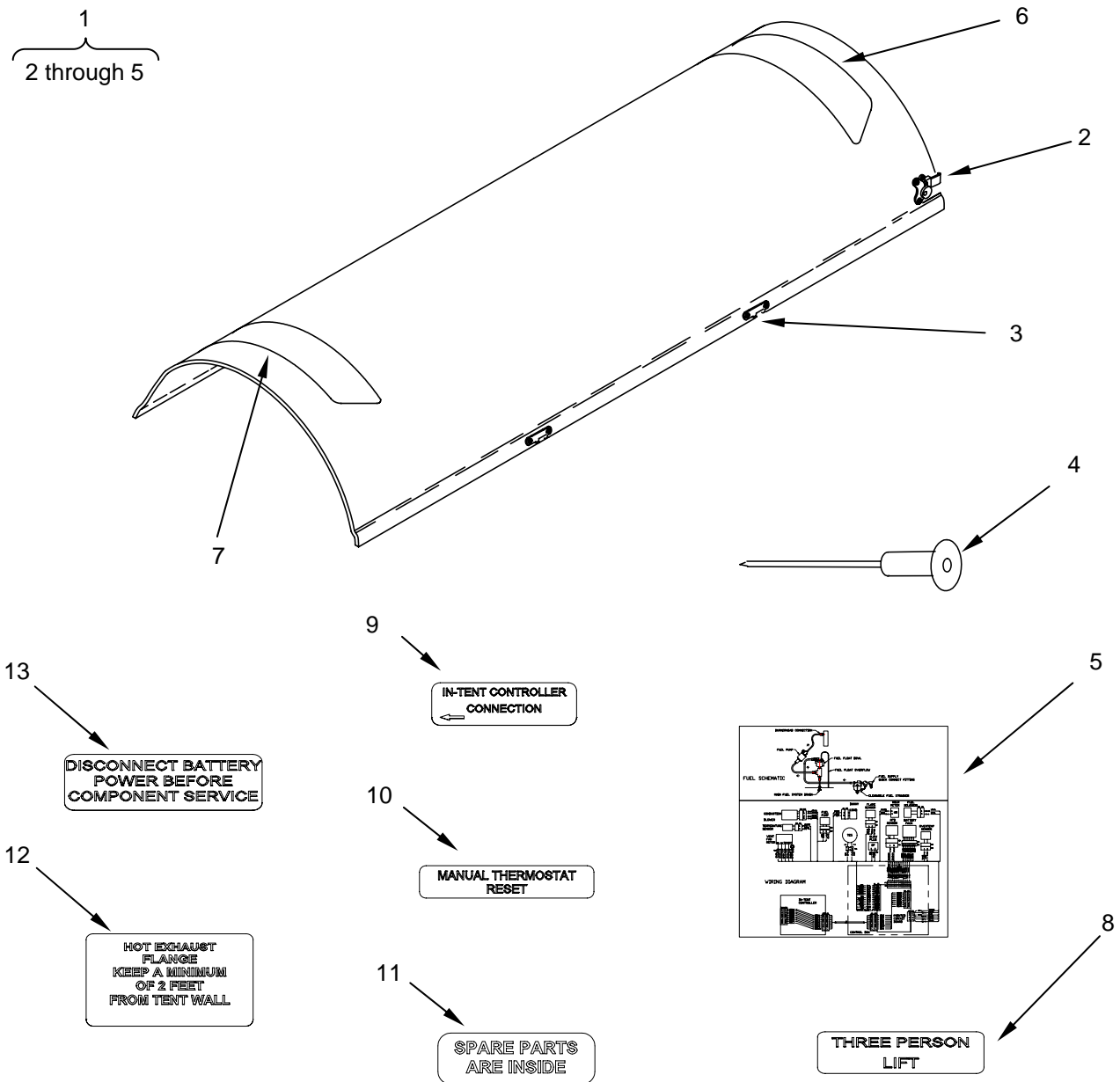

Figure 8. Upper Housing Assembly.

(1) ITEM NO	(2) SMR CODE	(3) NSN	(4) CAGEC	(5) PART NO.	(6) DESCRIPTION AND USABLE ON CODE (UOC)	(7) QTY
GROUP 07 UPPER HOUSING ASSEMBLY						
FIG. 7 UPPER HOUSING ASSEMBLY						
1	XDOOO		92878	160010	UPPER HOUSING ASSEMBLY.....	1
2	PAOZZ	5340-01-467-7561	94222	K3-1735-52	.CATCH, CLAMPING....	2
3	PAOZZ	5340-00-685-5899	94222	K3-0334-52	.STRIKE, CATCH.....	4
4	PAOZZ	5320-01-004-0238	81349	M24243/1D402	.RIVET, BLIND 1/8IN ID X 1/8 IN GRIP.....	12
5	XDOZZ		92878	160068	.WIRING DIAGRAM.....	1
6	XDOZZ		92878	5-13-5598-8	LABEL, "KEEP INLET CLEAR".....	1
7	XDOZZ		92878	5-13-5598-9	LABEL, "OUTLET SURFACE".....	1
8	XDOZZ		92878	160132	LABEL, "THREE PERSON LIFT".....	2
9	XDOZZ		92878	160133	LABEL, "IN-TENT CONTROLLER CONNECTION".....	1
10	XDOZZ		92878	160134	LABEL, "MANUAL RESET".....	1
11	XDOZZ		92878	160135	LABEL, "SPARE PARTS".....	1
12	XDOZZ		92878	5-13-5598-12	LABEL, "HOT EXHAUST SURFACE"..	1
13	XDOZZ		92878	5-13-5598-1	LABEL, "REMOVE BATTERY POWER BEFORE SERVICE".....	1
END OF FIGURE						

OPERATOR'S AND UNIT MAINTENANCE
SPACE HEATER, CONVECTIVE 60K BTU (SHC-60K)

NSN 4520-01-520-6477

EXHAUST GROMMET

REPAIR PARTS LIST

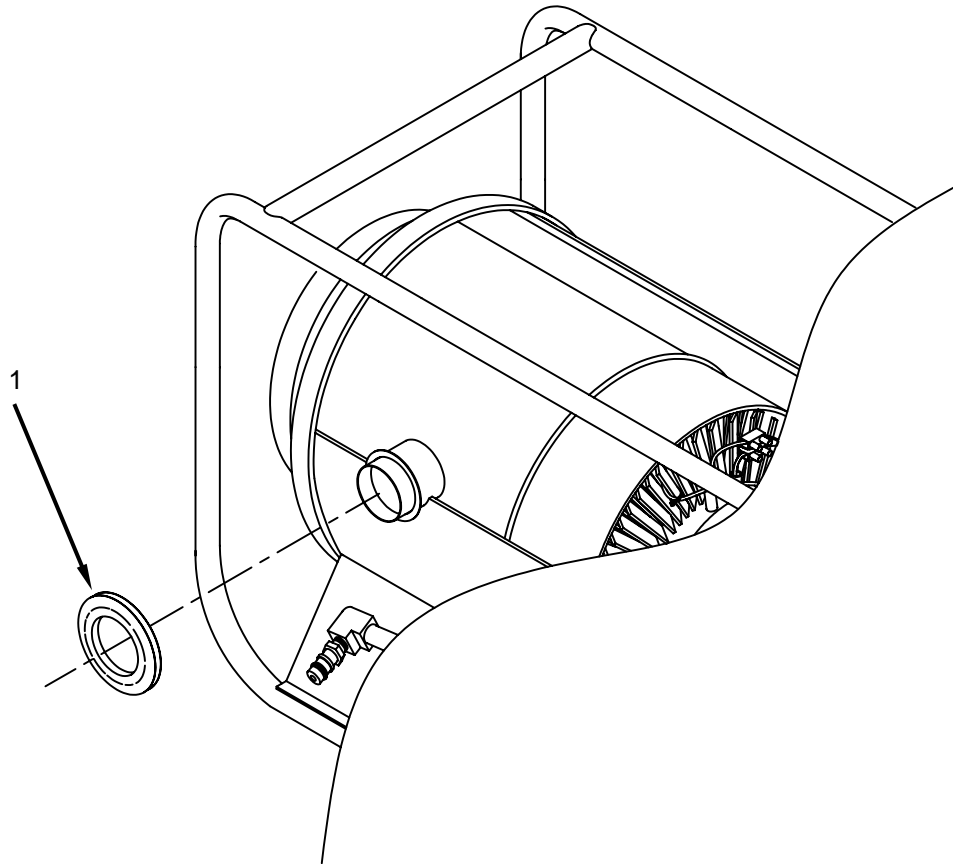

Figure 8. Exhaust Grommet.

(1) ITEM NO	(2) SMR CODE	(3) NSN	(4) CAGEC	(5) PART NO.	(6) DESCRIPTION AND USABLE ON CODE (UOC)	(7) QTY
GROUP 08 EXHAUST GROMMET FIG. 8 EXHAUST GROMMET						
1	PAOZZ	4520-01-493-2801	92878	5-13-5519	SHC GROMMET EXHAUST.....	1
END OF FIGURE						

**OPERATOR'S AND UNIT MAINTENANCE
SPACE HEATER, CONVECTIVE 60K BTU (SHC-60K)**

NSN 4520-01-520-6477

DUCT ADAPTERS

REPAIR PARTS LIST

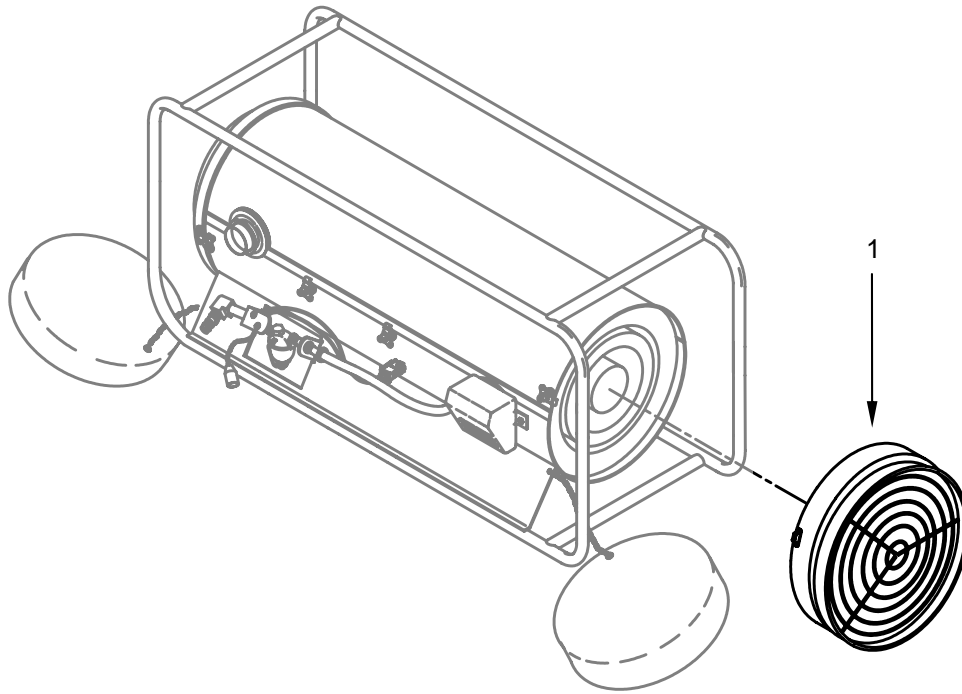

Figure 9. Duct Adapters.

(1) ITEM NO	(2) SMR CODE	(3) NSN	(4) CAGEC	(5) PART NO.	(6) DESCRIPTION AND USABLE ON CODE (UOC)	(7) QTY
GROUP 09 DUCT ADAPTERS FIG. 9 DUCT ADAPTERS						
1	PAOZZ	2540-01-544-6091	92878	160030	SHIELD, HEATER DUCT.....	2
END OF FIGURE						

OPERATOR'S AND UNIT MAINTENANCE
SPACE HEATER, CONVECTIVE 60K BTU (SHC-60K)

NSN 4520-01-520-6477

HEATED AIR BLOWER ASSEMBLY

REPAIR PARTS LIST

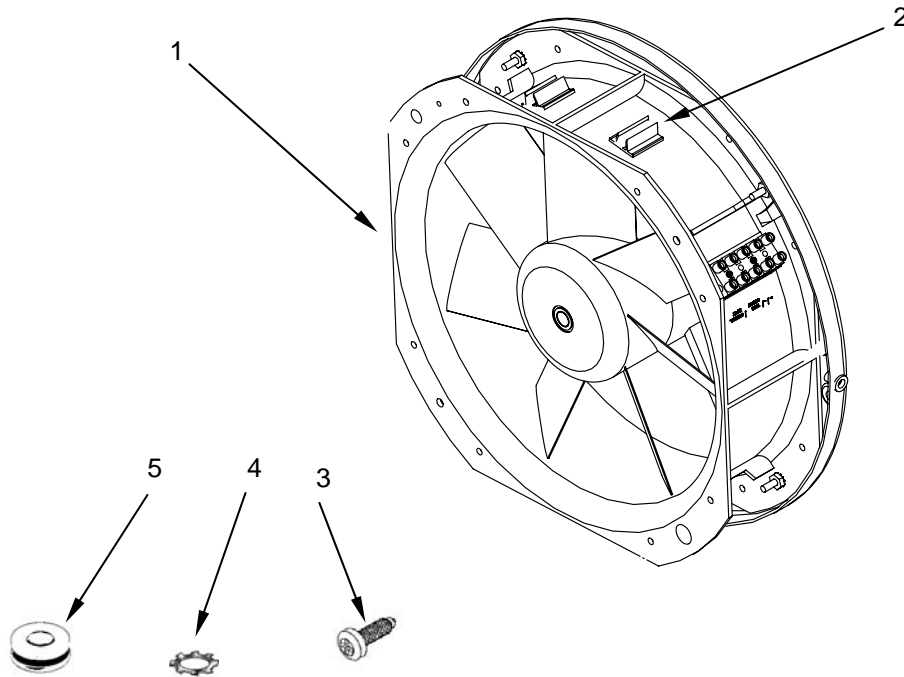

Figure 10. Heated Air Blower Assembly.

(1) ITEM NO	(2) SMR CODE	(3) NSN	(4) CAGEC	(5) PART NO.	(6) DESCRIPTION AND USABLE ON CODE (UOC)	(7) QTY
GROUP 10 HEATED AIR BLOWER ASSEMBLY FIG. 10 HEATED AIR BLOWER ASSEMBLY						
1	PAOZZ	4140-01-547-4937	92878	160179	BLOWER, AIR BARRIER.....	1
2	XDOZZ		92878	60465	.HOLDER, SPARE FUSE.....	2
3	PAOZZ	5305-00-989-7435	96906	MS35207-264	SCREW, MACHINE, PHM 10/32 X 5/8.....	1
4	PAOZZ	5310-00-596-7691	96906	MS35335-32	WASHER, LOCK, EXT NO. 10.....	1
5	PAOZZ	5325-00-263-6632	96906	MS35489-6	GROMMET, NONMETALLIC.....	1
END OF FIGURE						

**OPERATOR'S AND UNIT MAINTENANCE
SPACE HEATER, CONVECTIVE 60K BTU (SHC-60K)**

NSN 4520-01-520-6477

INLET AIR TEMPERATURE SENSOR

REPAIR PARTS LIST

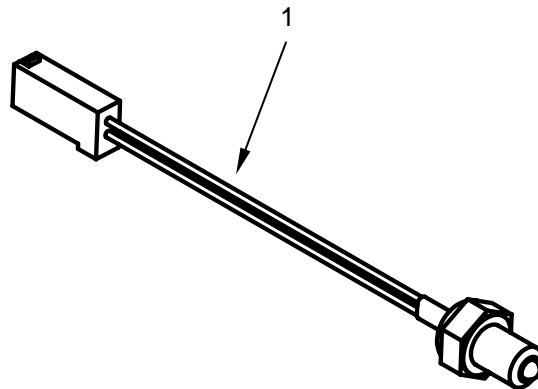

Figure 11. Inlet Air Temperature Sensor.

(1) ITEM NO	(2) SMR CODE	(3) NSN	(4) CAGEC	(5) PART NO.	(6) DESCRIPTION AND USABLE ON CODE (UOC)	(7) QTY
GROUP 11 INLET AIR TEMPERATURE SENSOR						
FIG. 11 INLET AIR TEMPERATURE SENSOR						
1	PAOZZ	5905-01-544-7481	92878	5-13-5615	SENSOR, TEMPERATURE, INLET AIR.....	1
END OF FIGURE						

OPERATOR'S AND UNIT MAINTENANCE
SPACE HEATER, CONVECTIVE 60K BTU (SHC-60K)

NSN 4520-01-520-6477

INTERNAL FUEL SYSTEM

REPAIR PARTS LIST

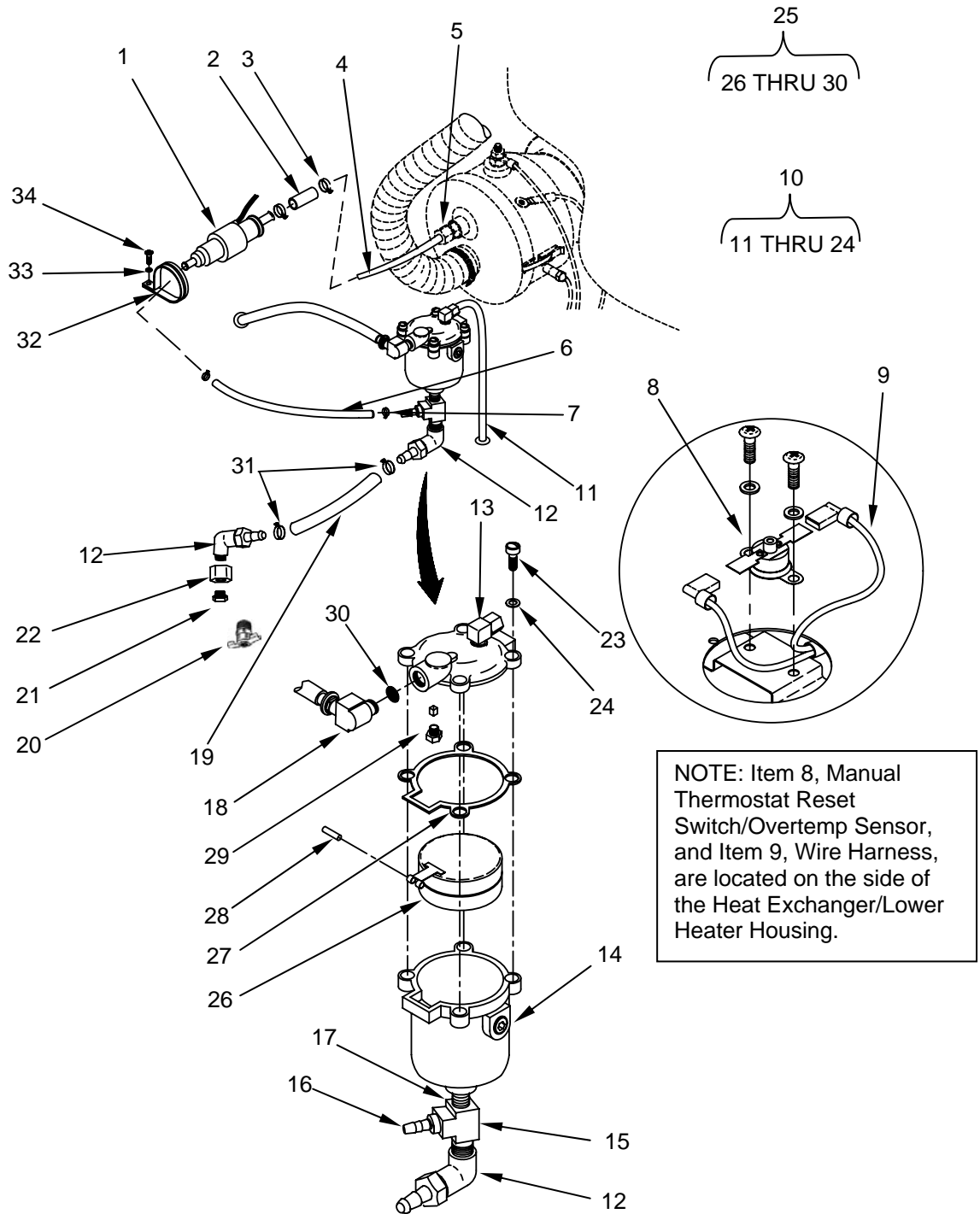

Figure 12. Internal Fuel System.

(1) ITEM NO	(2) SMR CODE	(3) NSN	(4) CAGEC	(5) PART NO.	(6) DESCRIPTION AND USABLE ON CODE (UOC)	(7) QTY
GROUP 12 INTERNAL FUEL SYSTEM FIG. 12 INTERNAL FUEL SYSTEM						
1	PAOZZ	2910-01-546-9418	92878	160180	FUEL PUMP ASSY.....	1
2	XDOZZ		92878	53563	.HOSE, 3/16ID X 1-1/ 2 L BACK.....	2
3	XDOZZ		92878	52175	.CLAMP, SPRING, 3/8 ID.....	1
4	XDOZZ		92878	160116	.TUBING, 0.188 OD TYPE.....	1
5	XDOZZ		92878	60454	.FITTING, COMPRESSION.....	1
6	XDOZZ		92878	160023	.0.25IN OD CLEAR FLEX TUBING.....	2
7	XDOZZ		92878	106544	.CLAMP, HOSE, SPRING TYPE.....	1
8	PAOZZ	6685-01-547-9081	92878	160033	MANUAL THERMOSTAT RESET SWITCH/OVERTEMP SENSOR.....	1
9	XDOZZ		92878	160034	OVERTEMP WIRE HARNESS.....	1
10	PAOZZ	4820-01-547-2723	92878	160022	FLOAT BOWL ASSEMBLY.....	1
11	XDOZZ		92878	60386	.VENT TUBE.....	1
12	XDOZZ		92878	53108	.ELBOW, 90 DEG HOSE BARB 1/8 IN MPT X 3/16 ID.....	2
13	PAOZZ	4730-00-640-1051	72582	225815	.ELBOW,PIPE TO TUBE.....	1
14	XDOZZ		1HP04	48307	.FLOAT BOWL.....	1
15	PAOZZ	4730-01-450-0847	89346	121761	.TEE, FEMALE, 1/8 IN PIPE.....	1
16	XDOZZ		92878	60566	.FITTING, HOSE BARB.	1
17	XDOZZ		92878	3789	.NIPPLE, CLOSE, 1/8 IN PIPE.....	1
18	XDOZZ		92878	60456	.ELBOW, MALE, 1/8 IN NPT X 1/4 IN TUBE.....	1
19	XDOZZ		92878	60479-1	.HOSE, 3/16 ID X 5 L BLACK RUBBER.....	1
20	PAOZZ	4820-00-752-9040	58536	AA59440/1-004	.COCK, DRAIN.....	1
21	XDOZZ		92878	47362	.CONNECTOR, FUEL SUPPLY.....	1
22	XDOZZ		92878	5697	.NUT, LOCK, 5/8 IN.....	1
23	PAOZZ	5305-00-823-5817	88044	AN500-8-8	.SCREW, MACHINE.....	4
24	PAOZZ	5310-00-807-4795	96906	MS35338-42	.WASHER, LOCK.....	4
25	PAOZZ	6680-01-544-7482	92878	170811	.KIT, FLOAT ASSEMBLY REPAIR.....	1

(1) ITEM NO	(2) SMR CODE	(3) NSN	(4) CAGEC	(5) PART NO.	(6) DESCRIPTION AND USABLE ON CODE (UOC)	(7) QTY
26	XDOZZ		92878	48390	..FLOAT.....	1
27	PAOZZ	5330-00-321-0982	92878	1601	..GASKET.....	1
28	PAOZZ	5315-00-276-4700	92878	1591	..PIN.....	1
29	PAOZZ	4520-00-962-1048	92878	48389	..NEEDLE ASSEMBLY..	1
30	XDOZZ		92878	23670	..INLET SCREEN.....	1
31	XDOZZ		92878	52175	..CLAMP, SPRING, 3/8 ID.....	2
32	PAOZZ	5340-00-904-3705	96906	MS21333-82	CLAMP, LOOP.....	1
33	PAOZZ	5310-00-596-7691	96906	MS35335-32	WASHER, LOCK, EXT..	1
34	PAOZZ	5305-00-989-7435	80205	MS35207-264	SCREW, MACHINE, PHM 10/32 X 5/8 IN.....	1
END OF FIGURE						

OPERATOR'S AND UNIT MAINTENANCE
SPACE HEATER, CONVECTIVE 60K BTU (SHC-60K)

NSN 4520-01-520-6477

BURNER ASSEMBLY AND RELATED COMPONENTS

REPAIR PARTS LIST

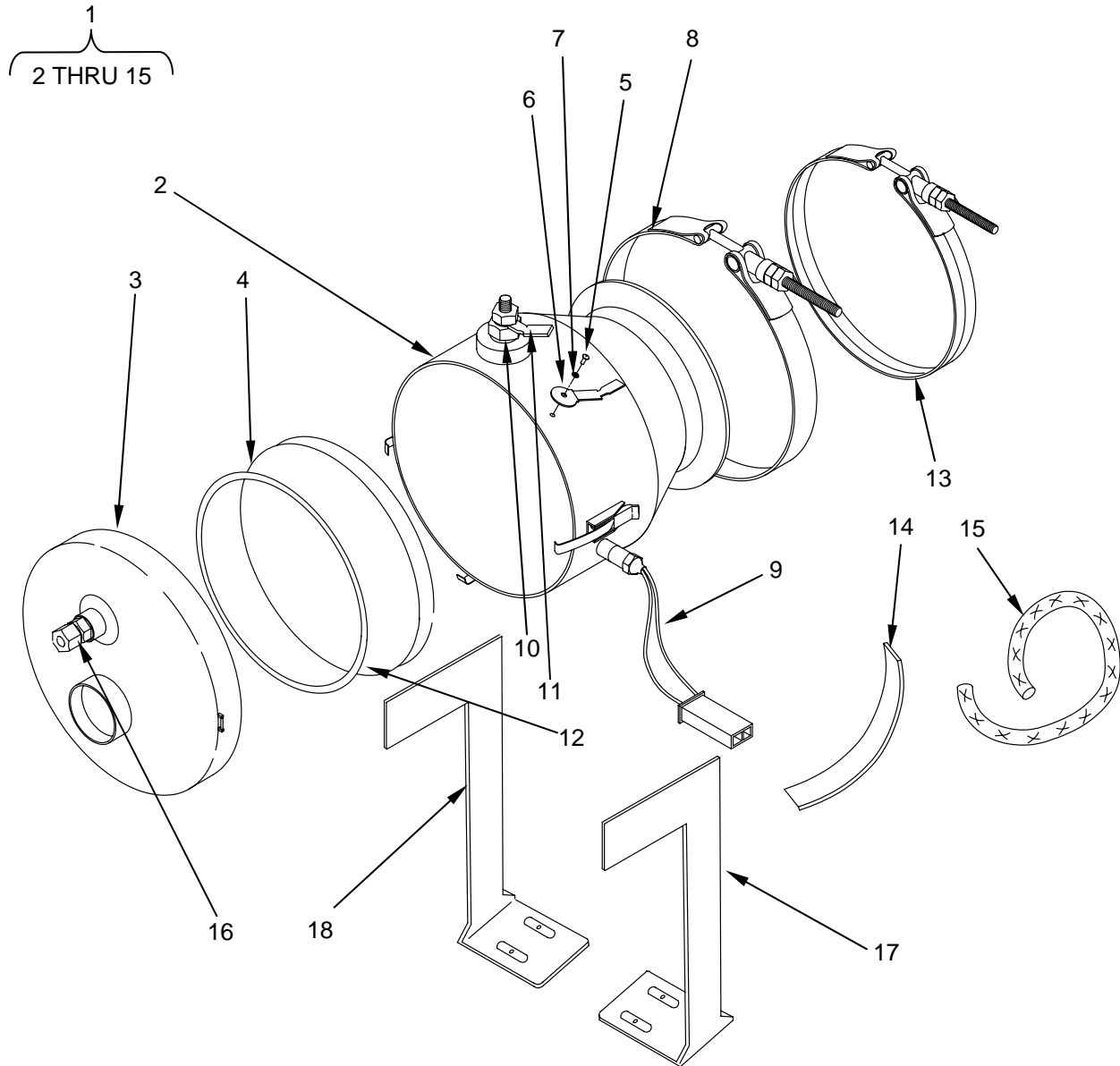

Figure 13. Burner Assembly and Related Components.

(1) ITEM NO	(2) SMR CODE	(3) NSN	(4) CAGEC	(5) PART NO.	(6) DESCRIPTION AND USABLE ON CODE (UOC)	(7) QTY
GROUP 13 BURNER ASSEMBLY AND RELATED COMPONENTS						
FIG. 13 BURNER ASSEMBLY AND RELATED COMPONENTS						
1	XDOOO		92878	160050	BURNER ASSEMBLY...	1
2	XDOZZ		92878	160051	.BURNER WELDMENT.....	1
3	XDOZZ		92878	160070	.BURNER COVER WELDMENT.....	1
4	PAOZZ	9390-01-547-8913	92878	160061	.WICK.....	1
5	XDOZZ		07707	AD42-BS	.RIVET, BLIND, 0.125 X 0.125 G.....	1
6	PAOZZ	4730-01-547-5837	92878	53533	.RECEPTACLE, QUICK DISCONNECT, 0.250 IN.....	1
7	PAOZZ	5310-00-579-0079	80205	MS35333-37	.WASHER, LOCK, INTERNAL TEETH NO. 6.....	1
8	PAOZZ	5340-01-547-5775	92878	160082	.BURNER CLAMP W/NUT.....	1
9	PAOZZ	4520-01-493-2781	92878	60470	.SHC SENSOR FLAME.....	1
10	PAOZZ	4520-01-493-2783	92878	60480	.SHC GLOW PLUG 12VDC.....	1
11	XDOZZ		92878	60469	..TAB, QUICK CONNECT.....	1
12	PAOZZ	5331-01-547-3602	92878	160084	.SEAL, O-RING.....	1
13	PAOZZ	4520-01-493-2792	92878	5-13-5457	.SHC CLAMP V BAND..	1
14	PAOZZ	4520-01-493-2812	92878	5-13-5594	.SHC SEAL GRAPHITE RIBBON TAPE.....	1
15	PAOZZ	4520-01-493-2811	92878	5-13-5599	.SHC ROPE FIBERGLASS.....	2
16	XDOZZ		92878	60454	CONNECTOR.....	1
17	XDOZZ		92878	160081-01	BURNER BRACKET, LEFT.....	1
18	XDOZZ		92878	160081-02	BURNER BRACKET, RIGHT.....	1
END OF FIGURE						

OPERATOR'S AND UNIT MAINTENANCE
SPACE HEATER, CONVECTIVE 60K BTU (SHC-60K)

NSN 4520-01-520-6477

THERMOELECTRIC GENERATOR (TEG)

REPAIR PARTS LIST

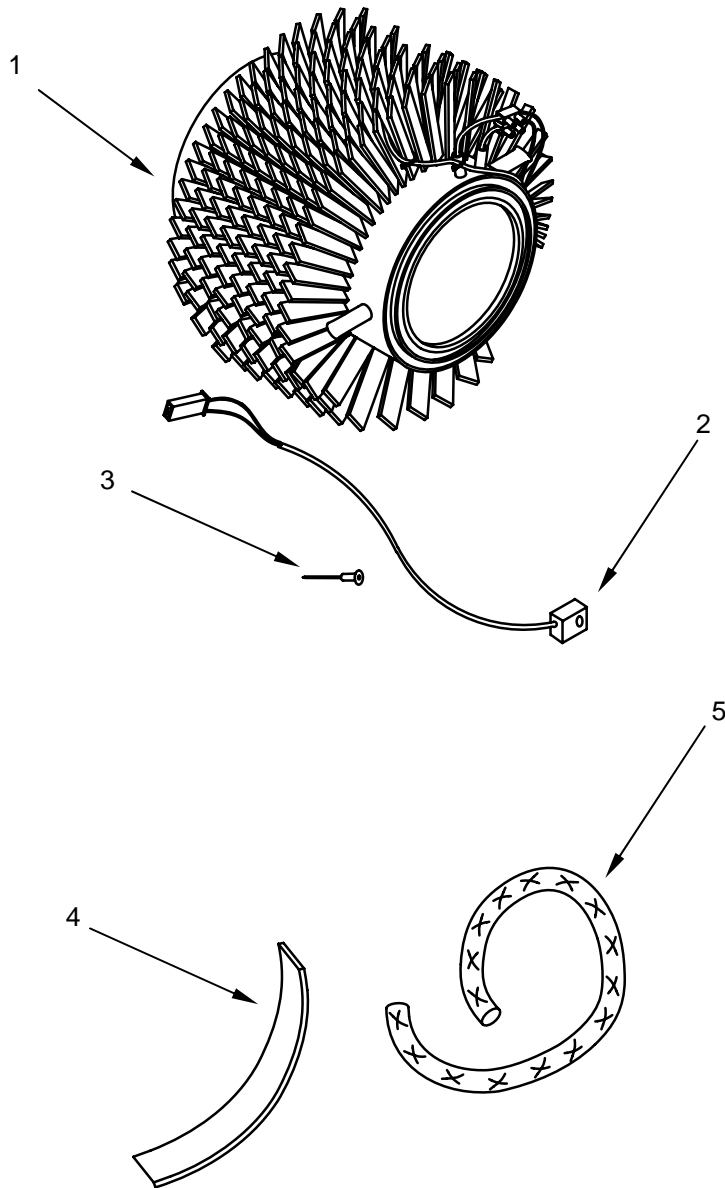

Figure 14. Thermoelectric Generator (TEG).

(1) ITEM NO	(2) SMR CODE	(3) NSN	(4) CAGEC	(5) PART NO.	(6) DESCRIPTION AND USABLE ON CODE (UOC)	(7) QTY
GROUP 14 THERMOELECTRIC GENERATOR (TEG) FIG. 14 THERMOELECTRIC GENERATOR (TEG)						
1	PAOOO	6115-01-544-7483	92878	160100	GENERATOR, THERMOELECTRIC.....	1
2	PAOZZ	5905-01-551-2856	92878	160111	.TEG FIN TEMPERATURE SENSOR ASSEMBLY...	1
3	PAOZZ	5320-01-004-0238	81349	M24243/1D402	.RIVET, BLIND 1/8IN ID X 1/8 GRIP.....	1
4	PAOZZ	4520-01-493-2812	92878	5-13-5594	.SHC SEAL GRAPHITE RIBBON TAPE.....	2
5	PAOZZ	4520-01-493-2811	92878	5-13-5599	.SHC ROPE FIBERGLASS.....	4
END OF FIGURE						

OPERATOR'S AND UNIT MAINTENANCE
SPACE HEATER, CONVECTIVE 60K BTU (SHC-60K)
NSN 4520-01-520-6477
HEAT EXCHANGER
REPAIR PARTS LIST

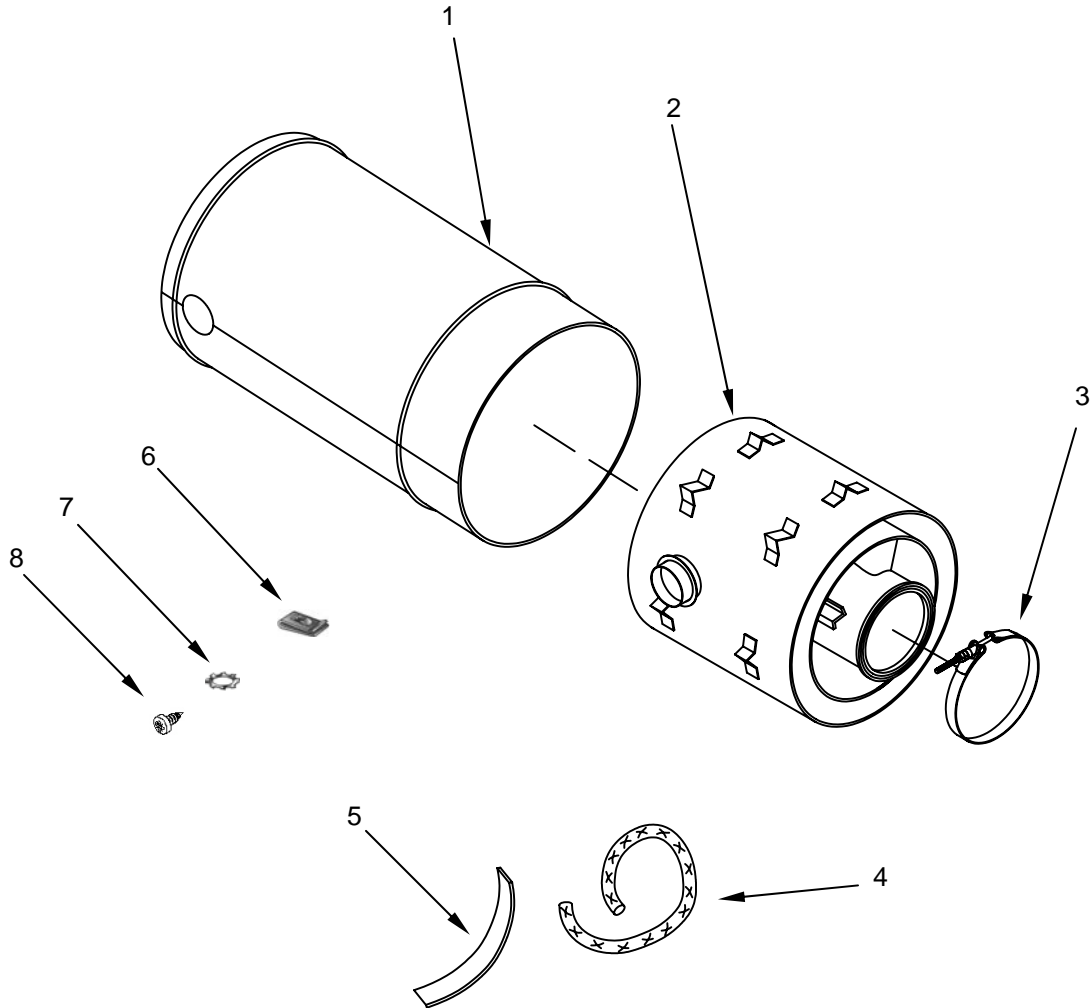

Figure 15. Heat Exchanger.

(1) ITEM NO	(2) SMR CODE	(3) NSN	(4) CAGEC	(5) PART NO.	(6) DESCRIPTION AND USABLE ON CODE (UOC)	(7) QTY
GROUP 15 HEAT EXCHANGER FIG. 15 HEAT EXCHANGER						
1	XDOZZ		92878	160021	COVER, WRAP.....	1
2	XDOZZ		92878	160150	HEAT EXCHANGER.....	1
3	PAOZZ	4520-01-493-2792	92878	5-13-5457	SHC CLAMP V BAND...	1
4	PAOZZ	4520-01-493-2811	92878	5-13-5599	SHC ROPE FIBERGLASS.....	2
5	PAOZZ	4520-01-493-2812	92878	5-13-5594	SHC SEAL GRAPHITE RIBBON TAPE.....	1
6	PAOZZ	5310-01-547-5807	78553	C-8108-8A-4	SPEED NUT, J TYPE....	9
7	PAOZZ	5310-00-209-0788	96906	MS35335-30	WASHER, LOCK #6 EXT.....	9
8	PAOZZ	5305-00-969-6914	45722	PK85XA6-6-1	SCREW, TAPPING, PHTF #6 X 3/8 IN.....	9
END OF FIGURE						

OPERATOR'S AND UNIT MAINTENANCE
SPACE HEATER, CONVECTIVE 60K BTU (SHC-60K)

NSN 4520-01-520-6477
LOWER HOUSING ASSEMBLY

REPAIR PARTS LIST

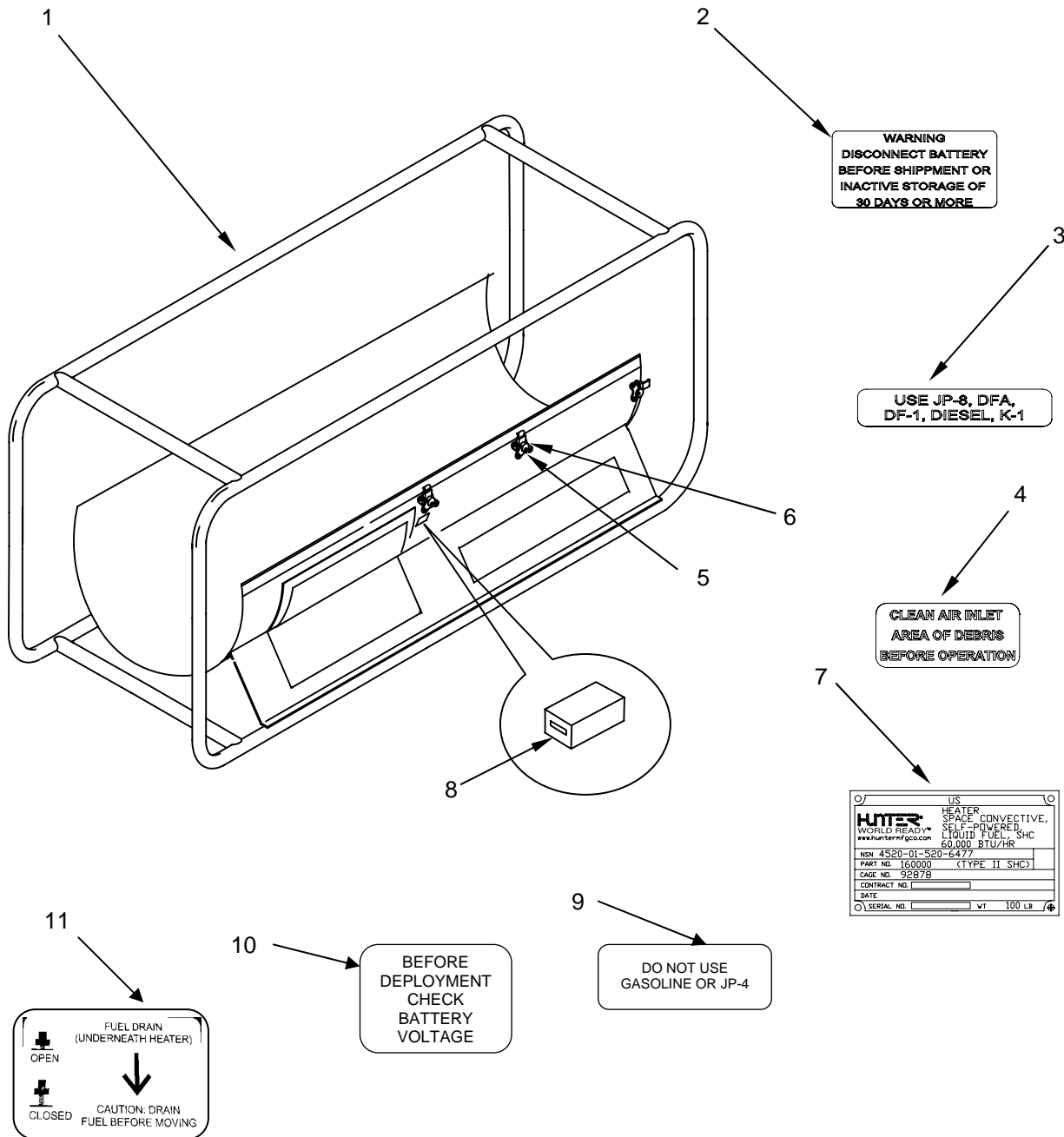

Figure 16. Lower Housing Assembly.

(1) ITEM NO	(2) SMR CODE	(3) NSN	(4) CAGEC	(5) PART NO.	(6) DESCRIPTION AND USABLE ON CODE (UOC)	(7) QTY
GROUP 16 LOWER HOUSING ASSEMBLY FIG. 16 LOWER HOUSING ASSEMBLY						
1	XDOZZ		92878	160007	LOWER HOUSING WELDMENT.....	1
2	XDOZZ		92878	5-13-5598-11	LABEL, "DISCONNECT BATTERY".....	1
3	XDOZZ		92878	5-13-5598-3	LABEL, "CAUTION USE JP-8".....	1
4	XDOZZ		92878	5-13-5598-7	LABEL, "CHECK AIR INLET".....	1
5	PAOZZ	5340-01-467-7561	94222	K3-1735-52	CATCH, CLAMPING.....	4
6	PAOZZ	5320-01-004-0238	81349	M24243/1D402	RIVET, BLIND 1/8IN ID X 1/8 IN GRIP.....	12
7	XDOZZ		92878	160127	IDENTIFICATION PLATE.....	1
8	PAOZZ	4520-01-493-2780	92878	60384	SHC HOUR METER.....	1
9	XDOZZ		92878	53588	LABEL, "DO NOT USE GASOLINE".....	1
10	XDOZZ		92878	53594	LABEL, "CKECK BATTERY".....	1
11	XDOZZ		92878	53589	LABEL, "FUEL DRAIN"	1
END OF FIGURE						

OPERATOR'S AND UNIT MAINTENANCE
SPACE HEATER, CONVECTIVE 60K BTU (SHC-60K)
NSN 4520-01-520-6477
AIR RETURN AND SUPPLY DUCTS WITH DEBRIS GRILL
REPAIR PARTS LIST

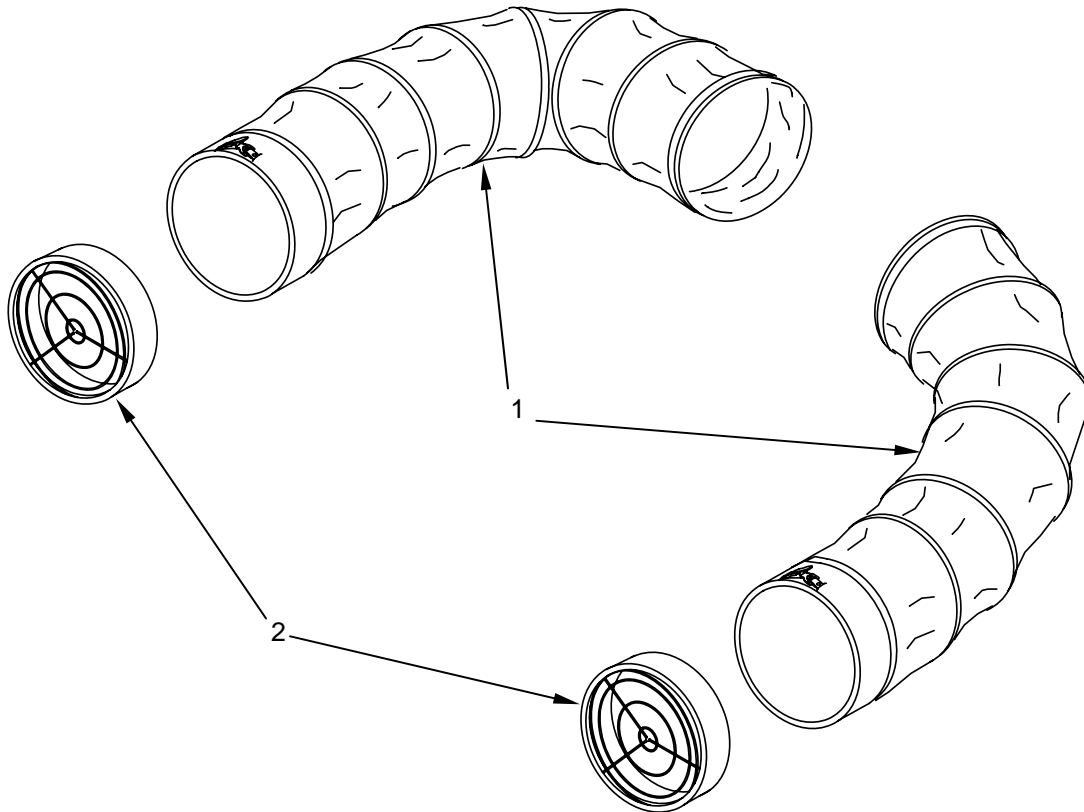

Figure 17. Air Return And Supply Ducts With Debris Grill.

(1) ITEM NO	(2) SMR CODE	(3) NSN	(4) CAGEC	(5) PART NO.	(6) DESCRIPTION AND USABLE ON CODE (UOC)	(7) QTY
GROUP 17 AIR RETURN AND SUPPLY DUCTS WITH DEBRIS GRILL						
FIG. 17 AIR RETURN AND SUPPLY DUCTS WITH DEBRIS GRILL						
1	PAOZZ	4720-01-547-7513	92878	160029	HOSE, AIR DUCT.....	2
2	PAOZZ	5340-01-547-7496	92878	160015	GRILLE, METAL.....	2
END OF FIGURE						

OPERATOR'S AND UNIT MAINTENANCE
SPACE HEATER, CONVECTIVE 60K BTU (SHC-60K)

NSN 4520-01-520-6477

SPARES, TOOLS, AND ACCESSORIES

REPAIR PARTS LIST

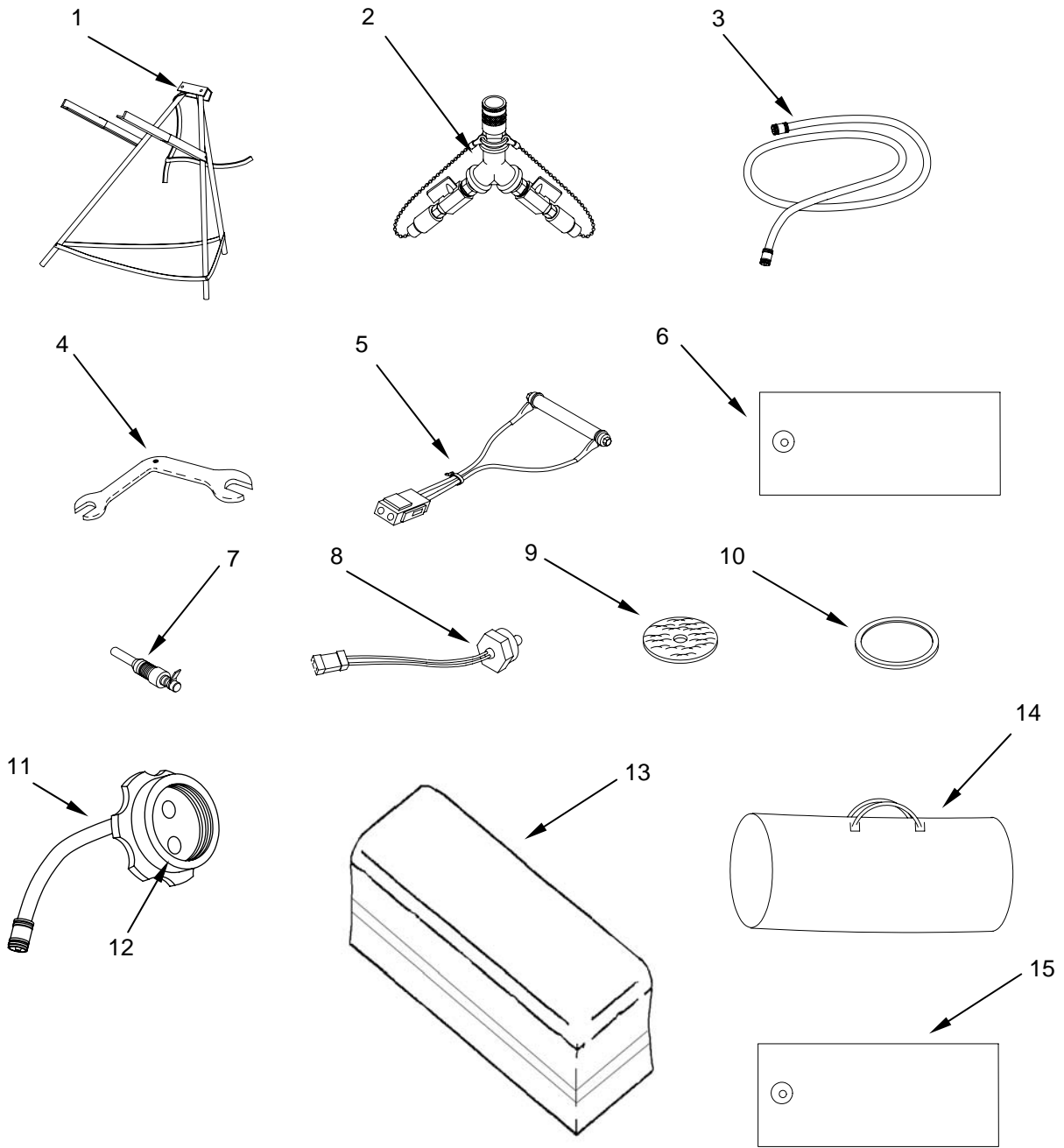

Figure 18. Spares, Tools, and Accessories.

(1) ITEM NO	(2) SMR CODE	(3) NSN	(4) CAGEC	(5) PART NO.	(6) DESCRIPTION AND USABLE ON CODE (UOC)	(7) QTY
GROUP 18 SPARES, TOOLS, AND ACCESSORIES FIG. 18 SPARES, TOOLS, AND ACCESSORIES						
1	PAOZZ	5340-01-547-5408	92878	80032	STAND ASSEMBLY, DOUBLE FUEL CAN....	1
2	PAOZZ	4730-01-547-5793	92878	80020	COUPLING ASSY, QUICK DISCONNECT Y ADAPTER.....	1
3	PAOZZ	4520-01-508-5743	92878	5-13-5630	SHC HOSE ASSY.....	1
4	PAOZZ	5120-01-544-8550	9 2878	160088	WRENCH.....	1
5	PAOZZ	4520-01-493-2810	92878	5-13-5593	SHC ADAPTER BATTERY.....	1
6	XDOZZ		92878	53554	TAG, INSTRUCTION....	1
7	PAOZZ	4520-01-493-2783	92878	60480	SHC GLOW PLUG 12VDC.....	1
8	PAOZZ	4520-01-493-2781	92878	60470	SHC SENSOR FLAME..	1
9	PAOZZ	4730-01-142-2738	10988	49923D	SCREEN, FUEL STRAINER.....	1
10	PAOZZ	5330-01-544-7473	1HP04	16B-185	GASKET, FUEL STRAINER.....	1
11	PAOZZ	4520-01-469-5775	92878	171230	SHC GRAVITY FEED ADAPTER.....	2
12	PAOZZ	4520-01-533-0627	92878	171236	.GRAVITY FEED ADAPTER UMBRELLA VALVE.....	1
13	PAOZZ	8145-01-547-2636	92878	160175	BAG, CARRYING- PADDED.....	1
14	PAOZZ	4520-01-506-2148	92878	53272	SHC ACCESSORY BAG.....	1
15	XDOZZ		92878	53552	ACCESSORY BAG TAG.....	1
END OF FIGURE						

**OPERATOR'S AND UNIT MAINTENANCE
SPACE HEATER, CONVECTIVE 60K BTU (SHC-60K)**

NSN 4520-01-520-6477

BULK ITEMS

REPAIR PARTS LIST

(1) ITEM NO	(2) SMR CODE	(3) NSN	(4) CAGEC	(5) PART NO.	(6) DESCRIPTION AND USABLE ON CODE (UOC)	(7) QTY
GROUP BULK FIG. BULK						
1	PAOZZ	4010-01-145-4658	96906	MS17311-1	CHAIN, WELDLESS.....	V
END OF FIGURE						

**OPERATOR'S AND UNIT MAINTENANCE
SPACE HEATER, CONVECTIVE 60K BTU (SHC-60K)**

NSN 4520-01-520-6477

NATIONAL STOCK NUMBER (NSN) INDEX

STOCK NUMBER	FIG.	ITEM	STOCK NUMBER	FIG.	ITEM
5310-00-014-5850	5	6		18	8
5310-00-067-6357	6	8	4520-01-493-2783	13	10
4730-00-142-2738	3	11		18	7
4730-00-193-2707	3	5	4520-01-493-2785	3	3
5310-00-209-0788	15	7	4520-01-493-2792	13	13
4730-00-230-1996	3	9		15	3
5325-00-263-6632	10	5	4520-01-493-2794	2	4
5315-00-276-4700	12	28	4520-01-493-2796	2	1
5325-00-291-9366	3	13	4520-01-493-2801	8	1
5330-00-321-0982	12	27	4520-01-493-2807	1	5
5305-00-432-4170	2	8	4520-01-493-2810	18	5
5310-00-559-0070	3	7	4520-01-493-2811	13	15
	2	7		14	5
5310-00-579-0079	13	7		15	4
5310-00-596-7691	4	3	4520-01-493-2812	13	14
	10	4		14	4
	12	33		15	5
4730-00-640-1051	12	13	4520-01-506-2148	18	14
5340-00-685-5899	7	3	4520-01-508-5743	18	3
4820-00-752-9040	12	20	5935-01-519-4930	4	2
4030-00-780-9350	1	2		1	3
5310-00-807-4795	12	24	2540-01-544-6091	9	1
5305-00-823-5817	12	23	5530-01-544-7473	3	12
5305-00-889-3002	3	6		18	10
5340-00-904-3705	12	32	4720-01-544-7474	3	15
2910-00-905-9792	3	10	5325-01-544-7476	3	18
4520-00-962-1048	12	29	5975-01-544-7477	4	1
5305-00-969-6914	15	8	5340-01-544-7478	5	1
5325-00-970-2419	6	9	5305-01-544-7479	6	2
5310-00-983-8483	5	2	5905-01-544-7481	11	1
5305-00-984-6193	5	5	6680-01-544-7482	12	25
5305-00-989-7434	6	7	6115-01-544-7483	14	1
5305-00-989-7435	4	4	5120-01-544-8550	18	4
	10	3	2910-01-546-9418	12	1
	12	34	8145-01-547-2636	18	13
5320-01-004-0238	5	3	4140-01-547-2717	6	1
	7	4	4820-01-547-2723	12	10
	14	3	5945-01-547-2731	3	8
	16	6	4520-01-547-2742	1	1
4730-01-093-7447	6	4	5331-01-547-3602	13	12
4730-01-142-2738	18	9	5945-01-547-4585	3	1
4010-01-145-4658	BULK	1	4140-01-547-4937	10	1
4730-01-206-8726	3	2	5340-01-547-5408	18	1
4730-01-450-0847	12	15	4730-01-547-5745	3	16
5340-01-467-7561	7	2	5340-01-547-5775	13	8
	16	5	4730-01-547-5793	18	2
4520-01-469-5775	18	11	5920-01-547-5807	2	10
4520-01-493-2777	2	3		15	6
4520-01-493-2780	16	8	4730-01-547-5817	3	19
4520-01-493-2781	13	9	4730-01-547-5837	13	6

STOCK NUMBER	FIG.	ITEM
5920-01-547-6326	2	2
5340-01-547-7496	17	2
4720-01-547-7513	17	1
9390-01-547-8913	13	4
6685-01-493-9081	12	8
5985-01-550-2487	2	9
5905-01-551-2856	14	2

OPERATOR'S AND UNIT MAINTENANCE
SPACE HEATER, CONVECTIVE 60K BTU (SHC-60K)

NSN 4520-01-520-6477

PART NUMBER INDEX

PART NUMBER	FIG.	ITEM	PART NUMBER	FIG.	ITEM
AA59440/1-004	12	20	5-13-5594	13	14
AD42-BS	13	5	5-13-5594	14	4
AN500-8-8	12	23		15	5
B-12SPECIAL1/8IN.MPT	3	2	5-13-5593	18	5
C-8108-8	2	10	5-13-5577	1	5
C-8108-8A-4	15	6	5-13-5553	3	19
	2	10	5-13-5519	8	1
K3-0334-52	7	3	5-13-5515	3	16
K3-1735-52	7	2	5-13-5469	2	1
	16	5	5-13-5468	2	4
M24243/1D402	5	3	5-13-5457	13	13
	7	4		15	3
	14	3	16B-185	3	12
	16	6		18	10
MIL-H-13444-1-3/8	3	17	62P12-BA	6	4
MS17311-1	BULK	1	1321	3	14
MS21333-82	12	32	1366	3	4
MS25043-18D	1	3	1591	12	28
	4	2	1601	12	27
MS27183-42	5	5	1625	6	9
MS27183-5	5	2	3326X2	3	9
MS35206-242	3	6	3789	12	17
MS35206-245	5	6	5697	12	22
MS35207-264	4	4	13705	6	7
	10	3	23670	12	30
	12	34	23824	3	18
MS35333-37	13	7	46273	2	3
MS35333-38	2	7	47362	12	21
	3	7	48307	12	14
MS35335-30	15	7	48389	12	29
MS35335-32	4	3	48390	12	26
	10	4	49923D	3	11
	12	33		18	9
MS35338-42	12	22	52175	12	3
MS35489-11	3	13		12	31
MS35489-6	10	5	53108	12	12
MS45904-69	6	8	53272	18	14
Ms51086-2	3	10	53533	13	6
MS51861-35	2	8	53552	18	15
MS87006-13	1	2	53554	18	6
PK85XA6-6-1	15	8	53563	12	2
5-13-5630	18	3	53588	16	9
5-13-5616	3	3	53589	16	11
5-13-5615	11	1	53594	16	10
5-13-5598-12	7	12	60384	16	8
5-13-5598-11	16	2	60386	12	11
5-13-5598-9	7	7	60454	12	5
5-13-5598-8	7	6		13	16
5-13-5598-7	16	4	60456	12	18
5-13-5598-3	16	3	60465	10	2
5-13-5599	13	15	60469	13	11
	14	5	60470	13	9
	15	4		18	8
5-13-5598-1	7	13	60479-1	12	19

PART NUMBER	FIG.	ITEM
60480	13	10
60480	18	7
60566	12	16
80020	18	2
80032	18	1
106544	12	7
121761	12	15
121830	3	5
160007	16	1
160010	7	1
160015	17	2
160018	6	2
160020	6	1
160021	15	1
160022	12	10
160023	12	6
160024	3	15
160025	6	6
160029	17	1
160030	9	1
160033	12	8
160034	12	9
160035	5	1
160037	2	6
160038	2	5
160040	4	1
160048	2	9
160050	13	1
160051	13	2
160061	13	4
160068	7	5
160070	13	3
160081-02	13	18
160081-01	13	17
160082	13	8
160084	13	12
160085	6	3
160088	18	4
160100	14	1
160111	14	2
160115	3	8
160116	12	4
160125	6	5
160127	16	7
160130	1	1
160131	1	4
160132	7	8
160133	7	9
160134	7	10
160135	7	11
160150	15	2
160175	18	13
160176	2	2
160177	3	1
160178	5	4
160179	10	1
160180	12	1
170811	12	25
171230	18	11
171236	18	12
225815	12	13

**OPERATOR'S AND UNIT MAINTENANCE
SPACE HEATER, CONVECTIVE, 60K BTU (SHC-60K)
NSN 4520-01-520-6477
COMPONENTS OF END ITEM (COEI) AND BASIC ISSUE ITEMS (BII) LISTS**

INTRODUCTION

Scope

This work package lists COEI and BII for the Space Heater, Convective 60K BTU (NSN 4520-01-520-6477) to help you inventory items for safe and efficient operation of the equipment.

General

The COEI and BII information is divided into the following lists:

Components of End Item (COEI). This list is for information purposes only and is not authority to requisition replacements. These items are part of the Space Heater, Convective, 60K BTU. As part of the end item, these items must be with the end item whenever it is issued or transferred between property accounts. Items of COEI are removed and separately packaged for transportation or shipment only when necessary. Illustrations are furnished to help you find and identify the items.

Basic Issue Items (BII). These essential items are required to place the Space Heater, Convective, 60K in operation, operate it, and do emergency repairs. Although shipped separately packages, BII must be with the Space Heater, Convective, 60K BTU during operation and when it is transferred between property accounts. Listing these items is your authority to request/requisition them for replacement based on authorization of the end item by the TOE/MTOE. Illustrations are furnished to help you find and identify the items.

Explanation of Columns in the COEI List and BII List

Column (1) Illus Number. Gives you the number of the item illustrated.

Column (2) National Stock Number (NSN). Identifies the stock number of the item to be used for requisitioning purposes.

Column (3) Description, CAGES, and Part Number. Identifies the Federal item name (in all capital letters) followed by a minimum description when needed. The stowage location of COEI and BII is also included in this column. The last line below the description is the CAGEC (Commercial and Government Entity Code) (in parentheses) and the part number.

Column (4) Usable On Code. When applicable, gives you a code if the item you need is not the same for different models of equipment.

Code Used On

Column (5) U/I. Unit of Issue (U/I) indicates the physical measurement or count of the item as issued per the National Stock Number shown in column (2).

Column (6). Qty Rqr. Indicates the quantity required.

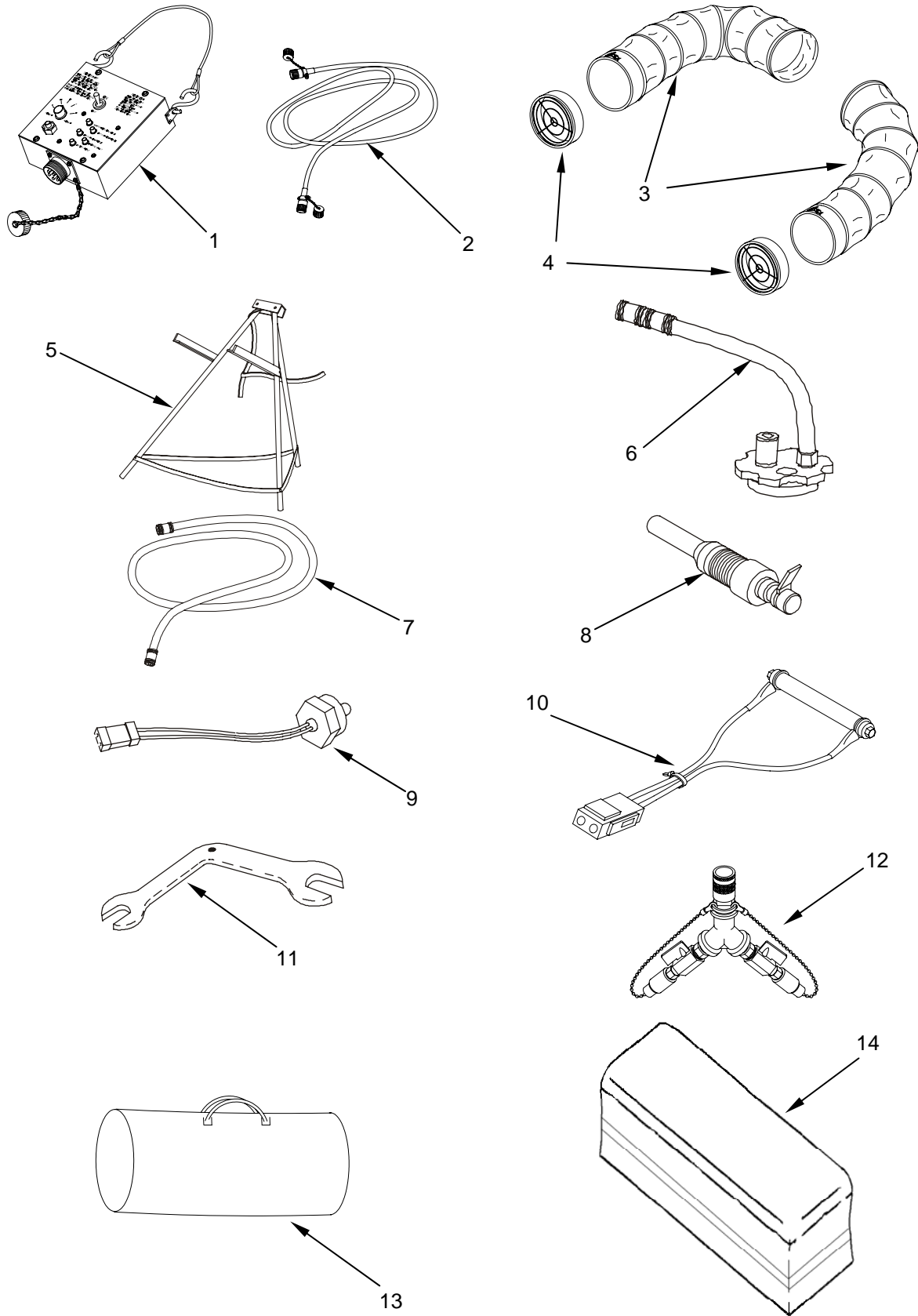

Figure 1. Components of End Item.

Table 1. Components of End Item List.

(1) ILLUS NUMBER	(2) NATIONAL STOCK NUMBER	(3) DESCRIPTION, (CAGEC), AND PART NUMBER	(4) USABLE ON CODE	(5) U/I	(6) QTY RQR
1		Control Box Assembly (92878) 160130		EA	1
2	4520-01-493-2807	Controller Cable Assembly, In-tent (92878) 5-13-5577		EA	1
3		Hose, Air Duct (92878) 160029		EA	2
4		Grille, Metal (92878) 160015		EA	2
5		Stand Assembly, Double Fuel Can (92878) 80032		EA	1
6	4520-01-469-5775	SHA Gravity Adapter (92878) 171230		EA	2
7	4520-01-508-5743	SHC Hose Assy (92878) 5-13-5630		EA	1
8	4520-01-493-2783	SHC Glow Plug 12 VDC (92878) 60480		EA	1
9	4520-01-493-2781	SHC Sensor, Flame (92878) 60470		EA	1
10	4520-01-493-2810	SHC Adapter Battery (92878) 5-13-5593		EA	1
11	5120-01-544-8550	Wrench, 9/16 inch by 12 mm (92878) 160088		EA	1
12		Coupling Assembly, Quick Disconnect, Y Adapter (92878) 80020		EA	1
13	4520-01-506-2148	SHC Accessory Bag (92878) 53272		EA	1
14		Storage Container, Flexible (92878) 160175		EA	1

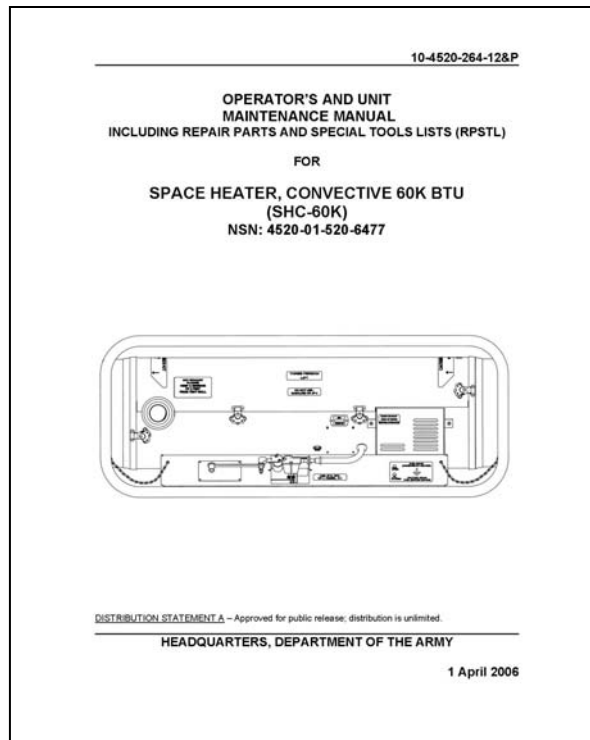

Figure 2. Basic Issue Items.

(1) ILLUS NUMBER	(2) NATIONAL STOCK NUMBER	(3) DESCRIPTION, (CAGEC), AND PART NUMBER	(4) USABLE ON CODE	(4) U/I	(5) QTY RQR
1		Operator's and Unit Maintenance Manual including Repair Parts and Special Tools List (RPSTL) for Space Heater, Convective 60K BTU (SHC-60K) TM 10-4520-264-12&P		EA	1

**OPERATOR'S AND UNIT MAINTENANCE MANUAL
SPACE HEATER, CONVECTIVE 60K BTU (SHC-60K)
NSN 4520-01-520-6477
ADDITIONAL AUTHORIZATION LIST (AAL)**

ADDITIONAL AUTHORIZATION LIST (AAL)

INTRODUCTION

Scope

This work package lists additional items you are authorized for the support of the Space Heater, Convective 60K BTU (SHC-60K).

General

This list identifies items that do not have to accompany the SHC-60K and that do not have to be turned in with it. These items are all authorized to you by CTA, MTOE, TDA, or JTA.

Explanation of Columns in the AAL

Column (1) National Stock Number (NSN). Identifies the stock number of the item to be used for requisitioning purposes.

Column (2) Description, Commercial and Government Entity Code (CAGEC), and Part Number (P/N). Identifies the Federal item name (in all capital letters) followed by a minimum description when needed. The last line below the description is the CAGEC (in parentheses) and the part number.

Column (3) Usable On Code. When applicable, gives you a code if the item you need is not the same for different models of equipment. These codes are identified below:

Code Used on

Column (4) Unit of Issue (U/I). Indicates the physical measurement or count of the item as issued per the National Stock Number shown in column (1).

Column (5) Qty Recm. Indicates the quantity recommended.

ADDITIONAL AUTHORIZED LIST ITEMS

Table 1. Additional Authorization List.

(1) NATIONAL STOCK NUMBER	(2) DESCRIPTION, (CAGEC) AND PART NUMBER	(3) USABLE ON CODE	(4) U/M	(5) QTY RECM
7240-01-337-5268	CAN (DT), FUEL, MILITARY (81349) MIL-C-53109		EA	1
7240-01-337-5269	CAN (CG), FUEL, MILITARY (81349) MIL-C-53109		EA	1
	KIT, COMBUSTION EXHAUST (92878) 5-13-5554		EA	1
	KIT, COMBUSTION INLET (92878) 5-13-5510		EA	1
4520-01-533-0607	NATO CHARGING SYSTEM (92878) 53587		EA	1
4520-01-493-3215	TENT WALL MODIFICATION KIT (92878) 5-13-5627		EA	1

END OF WORK PACKAGE

**OPERATOR'S AND UNIT MAINTENANCE
SPACE HEATER, CONVECTIVE 60K BTU (SHC-60K)
NSN 4520-01-520-6477
EXPENDABLE AND DURABLE ITEMS LIST**

INTRODUCTION

Scope

This work package lists expendable and durable items that you will need to operate and maintain the SHC-60K. This list is for information only and is not authority to requisition the listed items. These items are authorized to you by CTA 50-970, Expendable/Durable Items (Except Medical, Class V Repair Parts, and Heraldic Items), or CTA 8-100, Army Medical Department Expendable/Durable Items.

Explanation of Columns in the Expendable/Durable Items List

Column (1) Item Number. This number is assigned to the entry in the list and is referenced in the narrative instructions to identify the item (e.g., "Use brake fluid (item 5, WP 0098 00).").

Column (2) Level. This column identifies the lowest level of maintenance that requires the listed item (C = Operator/Crew).

Column (3) National Stock Number (NSN). This is the NSN assigned to the item which you can use to requisition it.

Column (4) Item Name, Description, Commercial and Government Entity Code (CAGEC), and Part Number (P/N). This column provides the other information you need to identify the item.

Column (5) Unit of Issue (U/I). Indicates the physical measurement or count of the item as issued per the National Stock Number shown in column (3).

(1) ITEM NUMBER	(2) LEVEL	(3) NATIONAL STOCK NUMBER	(4) ITEM NAME, DESCRIPTION, (CAGEC), AND PART NUMBER	(5) U/I
1	O	8040-00-973-4870	Adhesive (81349) MIL-A-21366	QT
2	O	6810-00-286-5435	Alcohol, Isopropyl (81348) TT-I-735	GL
3	C	7920-00-148-9666	Baled Rag, General (58536) A-A-2522	BE
4	O	7920-00-514-2417	Brush, Acid Swabbing (80244) 7920-00-514-2417	GR
5	O	8030-01-166-0675	Sealing Compound (05972) 56747	ML
6	C,O	5330-01-544-7473	Gasket (Included with spares at inlet of heater) (1HP04) 16B-18S	EA
7	C,O	4520-01-493-2783	Glow Plug (Included with spares at inlet of heater) (92878) 60480	EA
8	O	4520-01-533-0620	SHC Burner Kit (92878) 5-13-5628	EA
9	O		Kit, Float Assembly Repair (92878)	EA
10	O	7930-01-380-9028	Cleaning Lubricant, Greaseless 77A115284P3014 (03538)	BG
11	C,O	7930-01-363-8631	Absorbent Material, Oil and Water (1JA49) MAT203	BG
12	C,O		Screen (Included with spares at inlet of heater) (92878) 26370	EA
13	O	4520-01-493-2812	SHC Seal Graphite (92878) 5-13-5594	EA
14	C,O	4520-01-493-2781	SHC Sensor Flame (Included with spares at inlet of heater) (92878) 60470	EA
15	O	5640-00-103-2254	Tape, Duct (39428) 1791K70	RO
16	O	5970-00-644-3167	Tape, Insulation, Electrical, 3/4 Inch Width (58536) A-A-2094	RO
17	O	5975-00-727-5153	Strap, Tie-down, Electrical Component (81349) MIL-S-23190	HD
18	C,O	7930-01-316-6008	Absorbent Material, Oil and Water, Tray, (1JA49) 24100P	BX
19	O	7690-00-689-5212	Marker, Identification (56501) WM-A-33	EA

**OPERATOR'S AND UNIT MAINTENANCE
SPACE HEATER, CONVECTIVE 60K BTU (SHC-60K)
NSN 4520-01-520-6477
TORQUE LIMITS**

GENERAL

This work package provides general torque limits for fasteners. Special torque values are indicated in the maintenance procedures for applicable components. The general torque values given in this work package shall be used when specific torque values are not indicated in the maintenance procedures.

TORQUE LIMITS

Torque limits are listed in Tables 1 and 2 for fasteners. Dry fasteners are defined as fasteners on which no lubricants are applied to the threads. Wet fasteners are defined as fasteners on which graphite, molydisulphide greases, or other extreme pressure lubricants are applied to the threads. Table 3 lists the minimum breakaway torque values for locknuts.

Table 1. General Torque Requirements for Dry Fasteners (#2 through #10)*

Bolt/Screw Size	Torque Requirements in in.-lb (N-m)						
	18-8 Stainless Steel	Brass	Silicon Bronze	Aluminum 2024-T4	316 Stainless Steel	Monel	Nylon**
2-56	2.5 (0.28)	2.0(0.23)	2.3 (0.26)	1.4 (0.16)	2.6 (0.29)	2.5 (0.28)	0.44 (0.5)
2-64	3.0 (0.34)	2.5 (0.28)	2.8 (0.32)	1.7 (0.19)	3.2 (0.36)	3.1 (0.35)	
3-48	3.9 (0.44)	3.2 (0.36)	3.6 (0.41)	2.1 (0.24)	4.0 (0.45)	4.0 (0.45)	
3-56	4.4 (0.50)	3.6 (0.48)	4.1 (0.46)	2.4 (0.27)	4.6 (0.52)	4.5 (0.51)	
4-40	5.2 (0.59)	4.3 (0.49)	4.8 (0.54)	2.9 (0.33)	5.5 (0.62)	5.3 (0.60)	1.19 (0.13)
4.48	6.6 (0.75)	5.4 (0.61)	6.1 (0.69)	3.6 (0.41)	6.9 (0.78)	6.7 (0.76)	
5-40	7.7 (0.87)	6.3 (0.71)	7.1 (0.80)	4.2 (0.48)	8.1 (0.92)	7.8 (0.88)	
5-44	9.4 (1.06)	7.7 (0.87)	8.7 (0.98)	5.1 (0.58)	9.8 (1.11)	9.6 (1.09)	
6-32	9.6 (1.09)	7.9 (0.89)	8.9 (1.01)	5.3 (0.60)	10.1 (1.14)	9.8 (1.11)	2.14 (0.24)
6-40	12.1 (1.37)	9.9 (1.12)	11.2 (1.27)	6.6 (0.75)	12.7 (1.44)	12.3 (1.39)	
8-32	19.8 (2.24)	16.2 (1.83)	18.4 (2.08)	10.8 (1.22)	20.7 (2.34)	20.2 (2.28)	4.3 (0.49)
8-36	22.0 (2.49)	18.0 (2.03)	20.4 (2.31)	12.0 (1.36)	23.0 (2.60)	22.4 (2.53)	
10-24	22.8 (2.58)	18.6(2.10)	21.2 (2.40)	13.8 (1.56)	23.8 (2.69)	25.9 (2.93)	6.61 (0.75)
10-32	31.7 (3.58)	25.9 (2.93)	29.3 (3.31)	19.2 (2.17)	33.1 (3.74)	34.9 (3.94)	

* Torque given is for clean, dry threads. Reduce by 10% when lubricated.

** Nylon values only are breaking torque, rather than safe working torque.

Table 2. General Torque Requirements for Dry Fasteners (1/4-20 UNC through 1-1/2-12 UNF)*

Bolt/Screw Size	Torque Requirement in lb ft (N.m)			
	SAE Grade 1 or 2	SAE Grade 5	SAE Grade 6 or 7	SAE Grade 8
1/4-20 UNC	5 (7)	8 (11)	10 (14)	12 (16)
1/4-20UNF	7 (8)	10 (14)	12 (16)	14 (19)
5/16-18 UNC	11 (15)	17 (23)	19 (26)	24 (33)
5/16-24 UNF	13 (18)	19 (26)	23 (31)	27 (37)
3/8-16 UNC	18 (24)	31 (42)	34 (46)	44 (60)
3/8-24 UNF	20 (27)	35 (47)	42 (57)	49 (66)
7/16-14 UNC	28 (38)	49 (66)	55 (75)	70 (95)
7/16-20 UNF	30 (41)	55 (75)	67 (91)	78 (106)
1/2-13UNC	39 (53)	75 (102)	85 (115)	105 (142)
1/2-20UNF	41 (56)	85 (115)	102 (138)	120 (163)
9/16-12UNC	51 (69)	110 (149)	120 (163)	155 (210)
9/16-18UNF	55 (75)	120 (163)	145 (197)	170 (231)
5/8-11UNC	63 (85)	150 (203)	167 (226)	210 (285)
5/8-18 UNF	95 (129)	170 (231)	205 (278)	240 (325)
3/4-10 UNC	105 (142)	270 (366)	280 (380)	375 (509)
3/4-16 UNF	115 (156)	295 (400)	357 (484)	420 (570)
7/8-9 UNC	160 (217)	395 (536)	440 (597)	605 (820)
7/8-14 UNF	175 (237)	435 (590)	555 (753)	675 (915)
1-8 UNC	235 (319)	590 (800)	660 (895)	910 (1234)
1-14UNF	250 (339)	660 (865)	825 (1119)	999 (1342)
1-1/8-7 UNC	350 (475)	800 (1085)	1000 (1356)	1280 (1736)
1-1/8-12 UNF	400 (542)	880 (1193)	1050 (1424)	1440 (1953)
1-1/4-7 UNC	500 (678)	1080 (1464)	1325 (1797)	1820 (2468)
1-1/4-12UNF	550 (746)	1125 (1526)	1325 (1797)	1820 (2712)
1-3/8-6 UNC	660 (895)	1460 (1980)	1800 (2441)	2380 (3227)
1-3/8-12 UNF	740 (1003)	1680 (2278)	1960 (2658)	2720 (3688)
1-1/2-6UNC	870 (1180)	1940 (2631)	2913 (3950)	3160 (4285)
1-1/2-12 UNF	980 (1329)	2200 (2983)	3000 (4068)	3560 (4827)

* Torque given is for clean, dry threads. Reduce by 10% when lubricated.

NOTE

To determine breakaway torque, thread locknut onto screw or bolt until at least two threads stick out. Locknut shall not make contact with a mating part. Stop the locknut. Torque necessary to begin turning locknut again is the breakaway torque. Do not reuse locknuts that do not meet minimum breakaway torque.

Table 3. Locknut Breakaway Torque Values

Thread Size	Minimum Breakaway Torque	
	lb-in.	(N-m)
10-32	2.0	(0.23)
1/4-28	3.5	(0.40)
5/16-24	6.5	(0.73)
3/8-24	9.5	(1.07)
7/16-20	14.0	(1.58)
1/2-20	18.0	(2.03)
9/16-18	24.0	(2.71)
5/8-18	32.0	(3.62)
3/4-16	50.0	(5.65)
7/8-14	70.0	(7.91)
1-12	90.0	(10.17)
1-1/8-12	117.0	(13.22)

**OPERATOR'S AND UNIT MAINTENANCE
SPACE HEATER, CONVECTIVE 60K BTU (SHC-60K)
NSN 4520-01-520-6477
MANDATORY REPLACEMENT PARTS LIST**

MANDATORY REPLACEMENT PARTS LIST

This work package includes a list of all mandatory replacement parts referenced in the task initial setups and procedures. These are items that must be replaced during maintenance whether they have failed or not. This includes items based on usage intervals such as miles, time, rounds, fired, etc.

MANDATORY REPLACEMENT PARTS LIST

Table 1. Mandatory Replacement Parts.

ITEM NO.	PART NUMBER/ CAGEC	NSN	Nomenclature	QTY
1	5-13-5594	4520-01-493-2812	SHC, Seal Graphite	4

**SPACE HEATER, CONVECTIVE, 60K BTU
NSN 4520-01-520-6477
GLOSSARY**

A

AUDIBLE TONE - A sound made within the control box assembly to alert the operator of the heater or tent occupants to the occurrence of a heater SYSTEM FAULT condition. This tone will repeat a number of times to indicate the applicable DIAGNOSTIC CODE. See the back of the control box assembly for a description of the applicable code.

B

BATTERY CHARGED - The thermoelectric generator (TEG) has completed charging the battery.

BATTERY CHARGING - The TEG is charging the battery.

BREATHABLE AIR - Air heated by the heater and introduced into the tent. Also known as heated air. This air is completely separated from the combustion air system of the heater and is free of any products of combustion resulting from heater operation.

D

DEBRIS GRILL - A device on the end of a duct used to prevent foreign objects from entering the duct or heater during heater operation. This item is not a louver and is not used to direct heated air.

DUCT - Term used to designate an item attached to either the heated air outlet or the breathable air inlet of the heater and through which heated (breathable) air passes.

G

GEL CELL - A type of rechargeable battery. Also known as starved electrolyte cell.

H

HEATER ON/ON-HOLD - Advisory light on control panel assembly.

HEATED AIR - Air heated by the heater and introduced into the tent. Also known as breathable air. This air is completely separated from the combustion air system of the heater and is free of any products of combustion resulting from heater operation.

L

LOWER-HIGHER KNOB - A knob on the control panel assembly used to control the temperature within the tent.

P

PIPE - Term used to designate an item attached to the combustion air inlet or outlet of the heater and through which combustion air passes.

POST-PURGE - A stage of heater operation that follows normal operation and precedes heater shutdown. During this stage of operation, the heater's fuel supply is shutoff and the fans run to clear combustion gases from the heater systems and cooldown heater components.

PREPURGE - A stage of heater operation that precedes normal operation. During this stage of operation, heater fans run to purge heater systems.

S

SETPOINT - A term used to indicate that the ambient temperature within the tent has reached or exceeded the setting number at which the LOWER/HIGHER knob is positioned. This condition is indicated by the illumination of the AT SETPOINT advisory light on the control panel assembly.

SPACE HEATER, CONVECTIVE, 60K BTU
 NSN 4520-01-520-6477
 ALPHABETICAL INDEX

Subject **WP Sequence No. – Page No.**

A

Adapter, duct0039 00-1
 Additional authorization list0091 00-1
 Administrative storage.....0006 00-30
 Air Supply And Return Ducts, RPSTL Group 170085 00-1
 Assemble fuel can stand0005 00-9

B

Basic issue items (BII) list0090 00-1
 BATTERY CHARGED indicator does not light, troubleshooting procedures0009 00-1
 BATTERY CHARGING indicator does not light, troubleshooting procedures0010 00-1
 Battery pack assembly0043 00-1
 Battery Pack Assembly, RPSTL Group 20070 00-1
 Black smoke from heater exhaust, troubleshooting procedures0011 00-1
 Blower assembly, heated air0054 00-1
 Bulk, RPSTL Group0087 00-1
 Burner assembly0036 00-1
 Burner assembly0060 00-1
 Burner Assembly, RPSTL Group 130081 00-1

C

Capabilities and Features0002 00-2
 Characteristics and Capabilities.....0002 00-2
 Charging the Battery During Normal Operation.....0006 00-10
 Charging the Battery Using a NATO Charging System0006 00-11
 Cold, operation in extreme0007 00-5
 Combustion blower assembly0050 00-1
 Combustion Blower Assembly, RPSTL Group 60074 00-1
 Combustion blower duct assembly0051 00-1
 Components of end item (COEI) list & basic issue items (BII) list0090 00-1
 Components, Location and description of.....0002 00-3
 Connect fuel hose to heater0005 00-15
 Connect In-Tent Controller Assembly to In-Tent Controller Cable0005 00-17
 Controls and indicators0004 00-1
 Controls and indicators, description and use of operator0004 00-1
 Corrosion prevention and control (CPC).....0001 00-1
 CPC, corrosion prevention and control.....0001 00-1
 Criteria, site selection0005 00-6

D

Damage to Fuel Can, Gravity Feed Adapter, or Y Adapter0007 00-8
 Debris grills, installing in air supply and return ducts0005 00-24
 Decals and instruction plates0006 00-13
 Decontamination procedures, interim nuclear, biological, and chemical (NBC)0007 00-8
 Description and data, equipment0002 00-1
 Description and Use of Operator Controls and Indicators0004 00-1
 Destruction of army materiel to prevent enemy use0001 00-1
 Duct adapter.....0039 00-1

Subject

WP Sequence No. – Page No.

D - Continued

Duct Adapters, RPSTL Group 90077 00-1
 Duct assembly, combustion blower0051 00-1
 Ducts, installing the air supply and return0005 00-21
 Ducts, return and supply0064 00-1
 Dust cover assembly.....0049 00-1
 Dust Cover Assembly, RPSTL Group 50073 00-1

E

EIR, reporting equipment improvement recommendations0001 00-1
 Electronic Control System, RPSTL Group 40072 00-1
 Electronic data, security measures for0005 00-1
 Electronics box assembly, complete with wire harness.....0048 00-1
 Emergency procedures0007 00-8
 Enemy use, destruction of army materiel to prevent0001 00-1
 Equipment characteristics, capabilities, and features.....0002 00-1
 Equipment data0002 00-11
 Equipment Description and Data0002 00-1
 Exhaust fumes in shelter, troubleshooting procedures.....0012 00-1
 Exhaust grommet0053 00-1
 Exhaust Grommet, RPSTL Group 80076 00-1
 Expendable and durable items list0092 00-1
 Explanation of safety warning icons..... a
 External Fuel System Components, RPSTL Group 30071 00-1

F

Fault Code 1 – Low battery voltage, troubleshooting procedures0013 00-1
 Fault Code 10 – Tent over temperature, troubleshooting procedures.....0022 00-1
 Fault Code 11 – Low system voltage, troubleshooting procedures.....0023 00-1
 Fault Code 12 – Inlet air over-temperature, troubleshooting procedures.....0024 00-1
 Fault Code 14 – Fuel solenoid, troubleshooting procedures.....0025 00-1
 Fault Code 15 – Fuel pump/manual thermostat reset, troubleshooting procedures.....0026 00-1
 Fault Code 16 - Vent motor, troubleshooting procedures.....0027 00-1
 Fault Code 17 – Inlet air temperature sensor, troubleshooting procedures0028 00-1
 Fault Code 18 – Battery temperature sensor, troubleshooting procedures.....0029 00-1
 Fault Code 2 – Combustion fan blower motor, troubleshooting procedures0014 00-1
 Fault Code 3 – No flame, troubleshooting procedures0015 00-1
 Fault Code 4 – Burner maintenance, troubleshooting procedures0016 00-1
 Fault Code 5 – Glow plug, troubleshooting procedures.....0017 00-1
 Fault Code 6 – TEG over-temperature, troubleshooting procedures0018 00-1
 Fault Code 7 – Over voltage, troubleshooting procedures0019 00-1
 Fault Code 8 – Tip-over, troubleshooting procedures0020 00-1
 Fault Code 9 – Fin temp sensor, troubleshooting procedures.....0021 00-1
 Fill fuel can with fuel and install fuel can adapter0005 00-11
 Final checks before operation0005 00-25
 Flame sensor0037 00-1
 Float assembly0059 00-1
 Forms, records, and reports, maintenance0001 00-1
 Fuel can adapter, install0005 00-11
 Fuel can stand, assemble0005 00-9
 Fuel hose.....0047 00-1
 Fuel hose, connect to heater0005 00-15
 Fuel lines, internal0058 00-1

Subject

WP Sequence No. – Page No.

F - Continued

Fuel pump assembly0056 00-1
 Fuel quick disconnect.....0045 00-1
 Fuel selection0005 00-11
 Fuel solenoid valve and sediment strainer.....0046 00-1
 Fuel supply site, preparing0005 00-9

G

General information.....0001 00-1
 General safety0001 00-3
 General safety warnings description..... b
 Glow plug0038 00-1
 Gravity feed adapter, install0005 00-12
 Grommet, exhaust.....0053 00-1

H

Handling0001 00-3
 Heat exchanger0062 00-1
 Heat Exchanger, RPSTL Group 150083 00-1
 Heated air blower assembly.....0054 00-1
 Heated Air Blower Assembly, RPSTL Group 100078 00-1
 Heater assembly fuel selection0005 00-11
 Heater controls and indicators0004 00-1
 Heater fails to start, troubleshooting procedures0030 00-1
 Heater produces rumbling noise, troubleshooting procedures0031 00-1
 Heater setup.....0005 00-17
 Heater, starting the0006 00-2
 Heater, stopping the0006 00-5
 Hose, fuel0047 00-1
 Housing assembly, lower0063 00-1
 Housing assembly, upper0052 00-1
 How to use this manual..... v

I

Index, malfunction symptom0008 00-2
 Index, national stock number (NSN)0088 00-1
 Index, part number0089 00-1
 Index, troubleshooting0008 00-1
 Inlet air temperature sensor0055 00-1
 Inlet Air Temperature Sensor, RPSTL Group 110079 00-1
 Inspection Upon Receipt0005 00-1
 Install gravity feed adapter0005 00-12
 Installing Debris Grills in Air Supply and Return Ducts0005 00-24
 Installing the air supply and return ducts0005 00-21
 Instruction plates0006 00-13
 Instruction plates, location of.....0006 00-17
 In-tent controller and cable, routing through the tent duct tunnel0005 00-18
 In-tent Controller Assembly0041 00-1
 In-tent Controller Assembly Cable0042 00-1
 In-tent controller assembly, connect to in-tent controller cable.....0005 00-17
 In-tent controller, positioning inside the tent0005 00-20
 In-tent Controls, RPSTL Group 10069 00-1

Subject

WP Sequence No. – Page No.

I - Continued

Interim nuclear, biological, and chemical (NBC) decontamination procedures0007 00-8
 Internal fuel lines0058 00-1
 Internal Fuel System, RPSTL Group 120080 00-1
 Introduction, maintenance allocation chart (MAC)0066 00-1
 Introduction, Preventive Maintenance Checks and Services (PMCS)0032 00-1

J

JP-8, Limited Availability of0007 00-8

L

Limited Availability of JP-80007 00-8
 List of abbreviations/acronyms0001 00-2
 List of effective pages / work packagesA
 Load bank.....0044 00-1
 Location and description of major components0002 00-3
 Location of Labels and Instruction Plates0006 00-17
 Lower housing assembly.....0063 00-1
 Lower Housing Assembly, RPSTL Group 160084 00-1

M

Maintenance allocation chart (MAC).....0067 00-1
 Maintenance allocation chart (MAC) introduction0066 00-1
 Maintenance forms, records, and reports0001 00-1
 Maintenance procedures, operator0034 00-1
 Maintenance procedures, unit.....0040 00-1
 Malfunction symptom index.....0008 00-2
 Mandatory replacement parts0094 00-1
 Manual thermostat reset switch0057 00-1
 Material safety data sheet (MSDS).....0001 00-3
 Moderate climates, operation in0007 00-7
 Movement, preparation for0006 00-18
 MSDS, material safety data sheet0001 00-3

N

National stock number (NSN) index.....0088 00-1
 NATO charging system, charging the battery using a0006 00-11
 Nomenclature, names, and designations.....0001 00-2
 Normal operation.....0006 00-3

O

Official nomenclature, names, and designations0001 00-2
 On-hold.....0006 00-3
 Operation in extreme cold0007 00-5
 Operation in extreme rain, freezing rain, or snow0007 00-3
 Operation in extreme sand, dust, and/or high winds0007 00-1
 Operation in moderate climates0007 00-7
 Operation under unusual conditions0007 00-1
 Operation under usual conditions0006 00-1
 Operation under usual conditions - preparation for use.....0005 00-1

Subject

WP Sequence No. – Page No.

O - Continued

Operation, normal0006 00-3
 Operation, theory of0003 00-1
 Operator maintenance procedures0034 00-1

P

Part number index.....0089 00-1
 Plug, glow0038 00-1
 PMCS, Preventive Maintenance Checks and Services0033 00-1
 Positioning the Heater Outside Tent0005 00-8
 Positioning the In-tent Controller Inside the Tent.....0005 00-20
 POST, Power-on self test.....0006 00-3
 Power-on self test (POST)0006 00-3
 Preparation for movement.....0006 00-18
 Preparation for starting.....0006 00-1
 Preparation for storage or shipment0001 00-2
 Preparation for use.....0005 00-1
 Preparation for use, Operation under usual conditions0005 00-1
 Preparing a fuel supply site.....0005 00-9
 Preventive Maintenance Checks and Services (PMCS).....0033 00-1
 Preventive Maintenance Checks and Services (PMCS) Introduction.....0032 00-1
 Purpose of Equipment.....0001 00-1

Q

Quality of material0001 00-3
 Quick disconnect, fuel0045 00-1

R

Rain, freezing rain, or snow, operation in extreme0007 00-3
 References0065 00-1
 Refueling0006 00-7
 Repair parts and special tools list (RPSTL) introduction0068 00-1
 Reporting equipment improvement recommendations (EIR).....0001 00-1
 Return and supply ducts0064 00-1
 Routing the In-tent Controller and Cable Through the Tent Duct Tunnel0005 00-18
 RPSTL Group 1 In-tent Controls0069 00-1
 RPSTL Group 10 Heated Air Blower Assembly0078 00-1
 RPSTL Group 11 Inlet Air Temperature Sensor0079 00-1
 RPSTL Group 12 Internal Fuel System0080 00-1
 RPSTL Group 13 Burner Assembly0081 00-1
 RPSTL Group 14 Thermoelectric Generator0082 00-1
 RPSTL Group 15 Heat Exchanger.....0083 00-1
 RPSTL Group 16 Lower Housing Assembly0084 00-1
 RPSTL Group 17 Air Supply And Return Ducts.....0085 00-1
 RPSTL Group 18 Spares, Tools, Accessories.....0086 00-1
 RPSTL Group 2 Battery Pack Assembly0070 00-1
 RPSTL Group 3 External Fuel System Components.....0071 00-1
 RPSTL Group 4 Electronic Control System0072 00-1
 RPSTL Group 5 Dust Cover Assembly0073 00-1
 RPSTL Group 6 Combustion Blower Assembly.....0074 00-1
 RPSTL Group 7 Upper Housing Assembly0075 00-1
 RPSTL Group 8 Exhaust Grommet0076 00-1

Subject

WP Sequence No. – Page No.

R - Continued

RPSTL Group 9 Duct Adapters.....0077 00-1
 RPSTL Group Bulk.....0087 00-1

S

Safety warning icons, explanation of a
 Safety warnings, description b
 Safety, care, and handling0001 00-3
 Safety, general0001 00-3
 Sand, dust, and/or high winds, operation in extreme0007 00-1
 Security measures for electronic data.....0005 00-1
 Security measures for electronic data.....0007 00-1
 Sediment strainer0035 00-1
 Sensor, flame0037 00-1
 Sensor, Inlet air temperature0055 00-1
 Setup, heater0005 00-17
 Site selection criteria (outside the tent)0005 00-6
 Solenoid valve.....0046 00-1
 Spares, Tools, Accessories, RPSTL Group 180086 00-1
 Starting the Heater0006 00-2
 Starting, preparation for0006 00-1
 Stopping the heater.....0006 00-5
 Storage or shipment, preparation for0001 00-2
 Storage, administrative0006 00-30
 Strainer, sediment0035 00-1
 Switch, manual thermostat reset0057 00-1

T

TEG.....0061 00-1
 Tent wall modification kit (TWMK) installation0005 00-2
 Theory of operation.....0003 00-1
 Thermoelectric generator.....0061 00-1
 Thermoelectric Generator, RPSTL Group 140082 00-1
 Torque limits.....0093 00-1
 Troubleshooting index.....0008 00-1
 Troubleshooting Procedures - BATTERY CHARGED indicator does not light.....0009 00-1
 Troubleshooting Procedures - BATTERY CHARGING indicator does not light0010 00-1
 Troubleshooting Procedures - Black smoke from heater exhaust.....0011 00-1
 Troubleshooting Procedures - Exhaust fumes in shelter0012 00-1
 Troubleshooting Procedures - Fault Code 1 – Low battery voltage0013 00-1
 Troubleshooting Procedures - Fault Code 10 – Tent over temperature0022 00-1
 Troubleshooting Procedures - Fault Code 11 – Low system voltage0023 00-1
 Troubleshooting Procedures - Fault Code 12 – Inlet air over-temperature0024 00-1
 Troubleshooting Procedures - Fault Code 14 – Fuel solenoid0025 00-1
 Troubleshooting Procedures - Fault Code 15 – Fuel pump/manual thermostat reset.....0026 00-1
 Troubleshooting Procedures - Fault Code 16 - Vent motor0027 00-1
 Troubleshooting Procedures - Fault Code 17 – Inlet air temperature sensor.....0028 00-1
 Troubleshooting Procedures - Fault Code 18 – Battery temperature sensor0029 00-1
 Troubleshooting Procedures - Fault Code 2 – Combustion fan blower motor.....0014 00-1
 Troubleshooting Procedures - Fault Code 3 – No flame0015 00-1
 Troubleshooting Procedures - Fault Code 4 – Burner maintenance0016 00-1
 Troubleshooting Procedures - Fault Code 5 – Glow plug.....0017 00-1
 Troubleshooting Procedures - Fault Code 6 – TEG over-temperature.....0018 00-1

Subject

WP Sequence No. – Page No.

T - Continued

Troubleshooting Procedures - Fault Code 7 – Over voltage0019 00-1
Troubleshooting Procedures - Fault Code 8 – Tip-over.....0020 00-1
Troubleshooting Procedures - Fault Code 9 – Fin temp sensor0021 00-1
Troubleshooting Procedures - Heater fails to start0030 00-1
Troubleshooting Procedures - Heater produces rumbling noise0031 00-1
TWMK, tent wall modification kit installation0005 00-2
Type of Manual0001 00-1

U

Unit maintenance procedures0040 00-1
Unpacking and Inspection Upon Receipt.....0005 00-1
Unusual conditions, operation under0007 00-1
Upper housing assembly.....0052 00-1
Upper Housing Assembly, RPSTL Group 70075 00-1

W

Warning summary a
Wire harness0048 00-1

ARMY TM 10-4520-264-12&P

By Order of the Secretary of the Army:

PETER J. SCHOOMAKER
General, United States Army
Chief of Staff

Official:

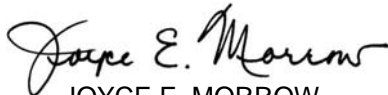

JOYCE E. MORROW
Administrative Assistant to the
Secretary of the Army
0705247

Distribution:

To be distributed in accordance with initial distribution number (IDN) 256928 requirements for TM 10-4520-264-12&P.

These are the instructions for sending an electronic 2028

The following format must be used if submitting an electronic 2028. The subject line must be exactly the same and all fields must be included; however only the following fields are mandatory: 1, 3, 4, 5, 6, 7, 8, 9, 10, 13, 15, 16, 17, and 27.

From: "Whomever" <whomever@avma27.army.mil>
To: soldier.pubs@us.army.mil

Subject: DA Form 2028

1. From: Joe Smith
2. Unit: home
3. Address: 4300 Park
4. City: Hometown
5. St: MO
6. Zip: 77777
7. Date Sent: 19-OCT-93
8. Pub no: 55-2840-229-23
9. Pub Title: TM
10. Publication Date: 04-JUL-85
11. Change Number: 7
12. Submitter Rank: MSG
13. Submitter FName: Joe
14. Submitter MName: T
15. Submitter LName: Smith
16. Submitter Phone: 123-123-1234
17. Problem: 1
18. Page: 2
19. Paragraph: 3
20. Line: 4
21. NSN: 5
22. Reference: 6
23. Figure: 7
24. Table: 8
25. Item: 9
26. Total: 123
27. Text:

This is the text for the problem below line 27.

RECOMMENDED CHANGES TO PUBLICATIONS AND BLANK FORMS For use of this form, see AR 25-30; the proponent agency is ODISC4.						Use Part II (reverse) for Repair Parts and Special Tool Lists (RPSTL) and Supply Catalogs/Supply Manuals (SC/SM).	DATE 21 October 2003
TO: (Forward to proponent of publication or form) (Include ZIP Code) Commander TACOM LIFE CYCLE MANAGEMENT COMMAND ATTN: AMSTA-LC-SECT 15 KANSAS ST NATICK, MA 01760-5052							
PART I – ALL PUBLICATIONS (EXCEPT RPSTL AND SC/SM) AND BLANK FORMS							
PUBLICATION/FORM NUMBER TM 10-1670-296-23&P				DATE 30 October 2002	TITLE Unit Manual for Ancillary Equipment for Low Velocity Air Drop Systems		
ITEM NO.	PAGE NO.	PARA-GRAPH	LINE NO. *	FIGURE NO.	TABLE NO.	RECOMMENDED CHANGES AND REASON <i>(Provide exact wording of recommended changes, if possible).</i>	
	0036 00-2				1	<i>In Table 1, Sewing Machine Code Symbols, the second sewing machine code symbol should be MDZZ not MD22</i> <i>Change the manual to show Sewing Machine, Industrial: Zig-Zag; 308 stitch; medium-duty; NSN 3530-01-181-1421 as a MDZZ code symbol.</i>	
<i>*Reference to line numbers within the paragraph or subparagraph.</i>							
TYPED NAME, GRADE OR TITLE Jane Doe, PFC				TELEPHONE EXCHANGE/AUTOVON, PLUS EXTENSION (508) 233-4141 DSN 256-4141		SIGNATURE Jane Doe <i>Jane Doe</i>	

TO: (Forward direct to addressee listed in publication) Commander TACOM LIFE CYCLE MANAGEMENT COMMAND ATTN: AMSTA-LC-SECT 15 KANSAS ST NATICK, MA 01760-5052	FROM: (Activity and location) (Include ZIP Code) PFC JANE DOE Co A 3 RD Engineer Br. Ft Leonard Wood, MO 63108	DATE 21 October 2003
--	---	--------------------------------

PART II – REPAIR PARTS AND SPECIAL TOOL LISTS AND SUPPLY CATALOGS/SUPPLY MANUALS

PUBLICATION NUMBER TM 10-1670-296-23&P	DATE 30 October 2002	TITLE Unit Manual for Ancillary Equipment for Low Velocity Air Drop Systems
---	-------------------------	--

PAGE NO.	COLM NO.	LINE NO.	NATIONAL STOCK NUMBER	REFERENCE NO.	FIGURE NO.	ITEM NO.	TOTAL NO. OF MAJOR ITEMS SUPPORTED	RECOMMENDED ACTION
0066 00-1					4			<i>Callout 16 in figure 4 is pointed to a <u>D-Ring</u>. In the Repair Part List key for Figure 4, item 16 is called a <u>Snap Hook</u>. Please correct one or the other.</i>

PART III – REMARKS (Any general remarks or recommendations, or suggestions for improvement of publications and blank forms. Additional blank sheets may be used if more space is needed.)

--

TYPED NAME, GRADE OR TITLE	TELEPHONE EXCHANGE/AUTOVON, PLUS EXTENSION	SIGNATURE
----------------------------	--	-----------

RECOMMENDED CHANGES TO PUBLICATIONS AND BLANK FORMS						Use Part II (<i>reverse</i>) for Repair Parts and Special Tool Lists (RPSTL) and Supply Catalogs/Supply Manuals (SC/SM).	DATE
For use of this form, see AR 25-30; the proponent agency is ODISC4.							
TO: (<i>Forward to proponent of publication or form</i>) (<i>Include ZIP Code</i>) Commander TACOM LIFE CYCLE MANAGEMENT COMMAND ATTN: AMSTA-LC-SECT Kansas Street, Natick, MA 01760-5052.						FROM: (<i>Activity and location</i>) (<i>Include ZIP Code</i>)	
PART I – ALL PUBLICATIONS (EXCEPT RPSTL AND SC/SM) AND BLANK FORMS							
PUBLICATION/FORM NUMBER TM 10-4520-264-12&P				DATE 5 March 2007		TITLE Space Heater, Convective 60K BTU (SHC-60K)	
ITEM NO.	PAGE NO.	PARA-GRAPH	LINE NO. *	FIGURE NO.	TABLE NO.	RECOMMENDED CHANGES AND REASON <i>(Provide exact wording of recommended changes, if possible).</i>	
<i>*Reference to line numbers within the paragraph or subparagraph.</i>							
TYPED NAME, GRADE OR TITLE				TELEPHONE EXCHANGE/AUTOVON, PLUS EXTENSION		SIGNATURE	

TO: <i>(Forward direct to addressee listed in publication)</i> Commander TACOM LIFE CYCLE MANAGEMENT COMMAND ATTN: AMSTA-LC-SECT Kansas Street, Natick, MA 01760-5052.	FROM: <i>(Activity and location) (Include ZIP Code)</i>	DATE
---	--	-------------

PART II – REPAIR PARTS AND SPECIAL TOOL LISTS AND SUPPLY CATALOGS/SUPPLY MANUALS

PUBLICATION NUMBER TM 10-4520-264-12&P	DATE 5 March 2007	TITLE Space Heater, Convective 60K BTU (SHC-60K)
---	----------------------	---

PAGE NO.	COLM NO.	LINE NO.	NATIONAL STOCK NUMBER	REFERENCE NO.	FIGURE NO.	ITEM NO.	TOTAL NO. OF MAJOR ITEMS SUPPORTED	RECOMMENDED ACTION

PART III – REMARKS *(Any general remarks or recommendations, or suggestions for improvement of publications and blank forms. Additional blank sheets may be used if more space is needed.)*

--

TYPED NAME, GRADE OR TITLE	TELEPHONE EXCHANGE/AUTOVON, PLUS EXTENSION	SIGNATURE
----------------------------	--	-----------

RECOMMENDED CHANGES TO PUBLICATIONS AND BLANK FORMS						Use Part II (<i>reverse</i>) for Repair Parts and Special Tool Lists (RPSTL) and Supply Catalogs/Supply Manuals (SC/SM).	DATE
For use of this form, see AR 25-30; the proponent agency is ODISC4.							
TO: (<i>Forward to proponent of publication or form</i>) (<i>Include ZIP Code</i>) Commander TACOM LIFE CYCLE MANAGEMENT COMMAND ATTN: AMSTA-LC-SECT Kansas Street, Natick, MA 01760-5052.						FROM: (<i>Activity and location</i>) (<i>Include ZIP Code</i>)	
PART I – ALL PUBLICATIONS (EXCEPT RPSTL AND SC/SM) AND BLANK FORMS							
PUBLICATION/FORM NUMBER TM 10-4520-264-12&P				DATE 5 March 2007		TITLE Space Heater, Convective 60K BTU (SHC-60K)	
ITEM NO.	PAGE NO.	PARA-GRAPH	LINE NO. *	FIGURE NO.	TABLE NO.	RECOMMENDED CHANGES AND REASON <i>(Provide exact wording of recommended changes, if possible).</i>	
<i>*Reference to line numbers within the paragraph or subparagraph.</i>							
TYPED NAME, GRADE OR TITLE				TELEPHONE EXCHANGE/AUTOVON, PLUS EXTENSION		SIGNATURE	

TO: <i>(Forward direct to addressee listed in publication)</i> Commander TACOM LIFE CYCLE MANAGEMENT COMMAND ATTN: AMSTA-LC-SECT Kansas Street, Natick, MA 01760-5052.	FROM: <i>(Activity and location) (Include ZIP Code)</i>	DATE
---	--	-------------

PART II – REPAIR PARTS AND SPECIAL TOOL LISTS AND SUPPLY CATALOGS/SUPPLY MANUALS

PUBLICATION NUMBER TM 10-4520-264-12&P	DATE 5 March 2007	TITLE Space Heater, Convective 60K BTU (SHC-60K)
---	----------------------	---

PAGE NO.	COLM NO.	LINE NO.	NATIONAL STOCK NUMBER	REFERENCE NO.	FIGURE NO.	ITEM NO.	TOTAL NO. OF MAJOR ITEMS SUPPORTED	RECOMMENDED ACTION

PART III – REMARKS *(Any general remarks or recommendations, or suggestions for improvement of publications and blank forms. Additional blank sheets may be used if more space is needed.)*

TYPED NAME, GRADE OR TITLE	TELEPHONE EXCHANGE/AUTOVON, PLUS EXTENSION	SIGNATURE
----------------------------	--	-----------

**SPACE HEATER, CONVECTIVE 60K BTU (SHC-60K)
NSN 4520-01-520-6477
WIRING DIAGRAM**

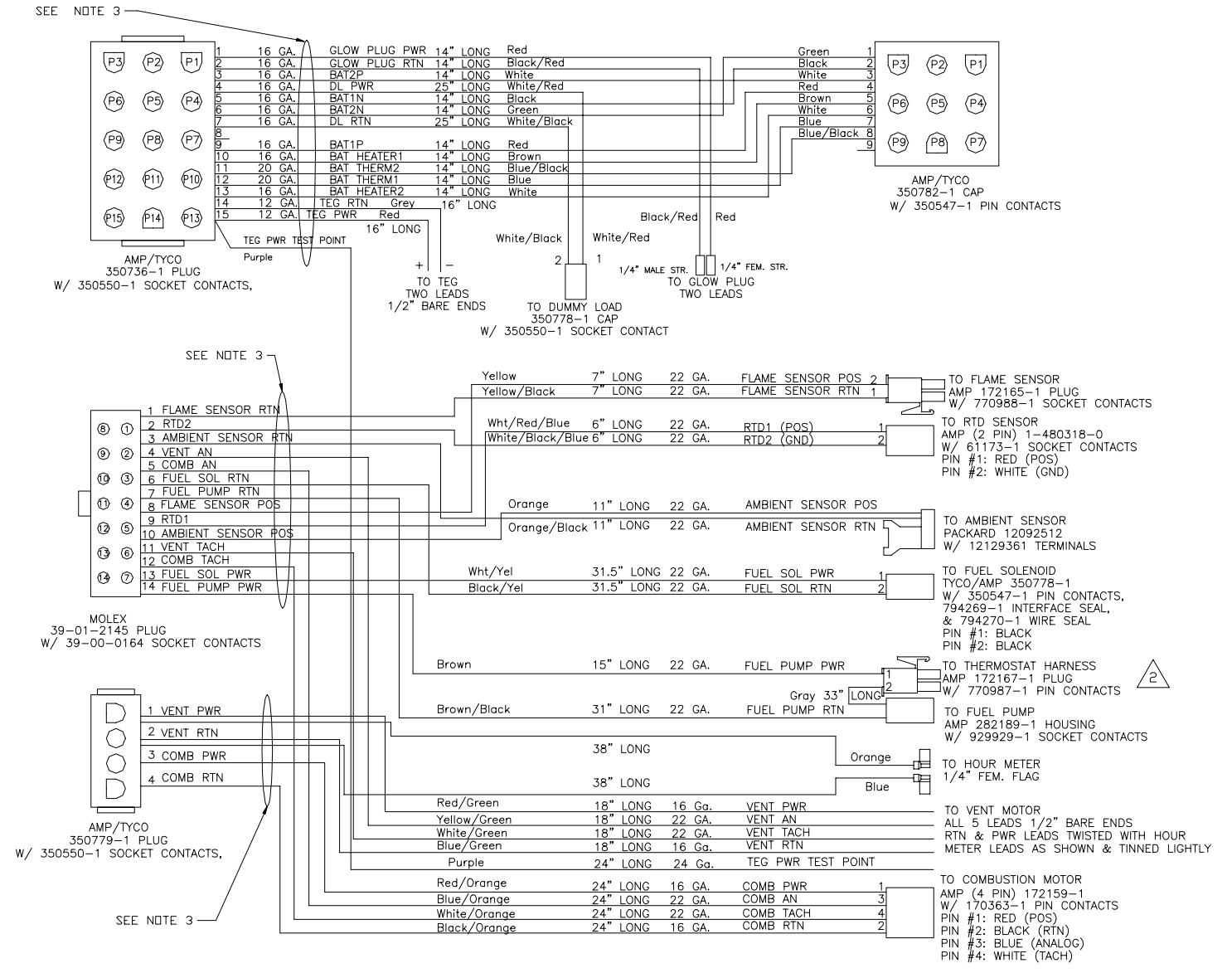

The Metric System and Equivalents

Linear Measure

1 centimeter = 10 millimeters = .39 inch
 1 decimeter = 10 centimeters = 3.94 inches
 1 meter = 10 decimeters = 39.37 inches
 1 dekameter = 10 meters = 32.8 feet
 1 hectometer = 10 dekameters = 328.08 feet
 1 kilometer = 10 hectometers = 3,280.8 feet

Weights

1 centigram = 10 milligrams = .15 grain
 1 decigram = 10 centigrams = 1.54 grains
 1 gram = 10 decigrams = .035 ounce
 1 dekagram = 10 grams = .35 ounce
 1 hectogram = 10 dekagrams = 3.52 ounces
 1 kilogram = 10 hectograms = 2.2 pounds
 1 quintal = 100 kilograms = 220.46 pounds
 1 metric ton = 10 quintals = 1.1 short tons

Liquid Measure

1 centiliter = 10 milliliters = .34 fl. ounce
 1 deciliter = 10 centiliters = 3.38 fl. ounces
 1 liter = 10 deciliters = 33.81 fl. ounces
 1 dekaliter = 10 liters = 2.64 gallons
 1 hectoliter = 10 dekaliters = 26.42 gallons
 1 kiloliter = 10 hectoliters = 264.18 gallons

Square Measure

1 sq. centimeter = 100 sq. millimeters = .15 sq. inch
 1 sq. decimeter = 100 sq. centimeters = 15.5 sq. inches
 1 sq. meter (centare) = 100 sq. decimeters = 10.76 sq. feet
 1 sq. dekameter (are) = 100 sq. meters = 1,076.4 sq. feet
 1 sq. hectometer (hectare) = 100 sq. dekameters = 2.47 acres
 1 sq. kilometer = 100 sq. hectometers = .386 sq. mile

Cubic Measure

1 cu. centimeter = 1000 cu. millimeters = .06 cu. inch
 1 cu. decimeter = 1000 cu. centimeters = 61.02 cu. inches
 1 cu. meter = 1000 cu. decimeters = 35.31 feet

Approximate Conversion Factors

<i>To change</i>	<i>To</i>	<i>Multiply by</i>	<i>To change</i>	<i>To</i>	<i>Multiply by</i>
inches	centimeters	2.540	ounce-inches	newton-meters	.007062
feet	meters	.305	centimeters	inches	.394
yards	meters	.914	meters	feet	3.280
miles	kilometers	1.609	meters	yards	1.094
square inches	square centimeters	6.451	kilometers	miles	.621
square feet	square meters	.093	square centimeters	square inches	.155
square yards	square meters	.836	square meters	square feet	10.764
square miles	square kilometers	2.590	square meters	square yards	1.196
acres	square hectometers	.405	square kilometers	square miles	.386
cubic feet	cubic meters	.028	square hectometers	acres	2.471
cubic yards	cubic meters	.765	cubic meters	cubic feet	35.315
fluid ounces	milliliters	29.573	cubic meters	cubic yards	1.308
pints	liters	.473	milliliters	fluid ounces	.034
quarts	liters	.946	liters	pints	2.113
gallons	liters	3.785	liters	quarts	1.057
ounces	grams	28.349	grams	gallons	.264
pounds	kilograms	.454	liters	ounces	.035
short tons	metric tons	.907	kilograms	pounds	2.205
pound-feet	newton-meters	1.356	metric tons	short tons	1.102
pound-inches	newton-meters	.11296			

Temperature (Exact)

$\frac{5}{9}$ (after subtracting 32) $\frac{5}{9}$ (after subtracting 32) Celsius temperature $\frac{5}{9}$ (after subtracting 32) Celsius temperature

PIN: 083860-000